

End To End Speech Quality: Just One Number?

Dr.-Ing. H.W. Gierlich
HEAD acoustics GmbH, Herzogenrath

The Telephone Conversation:

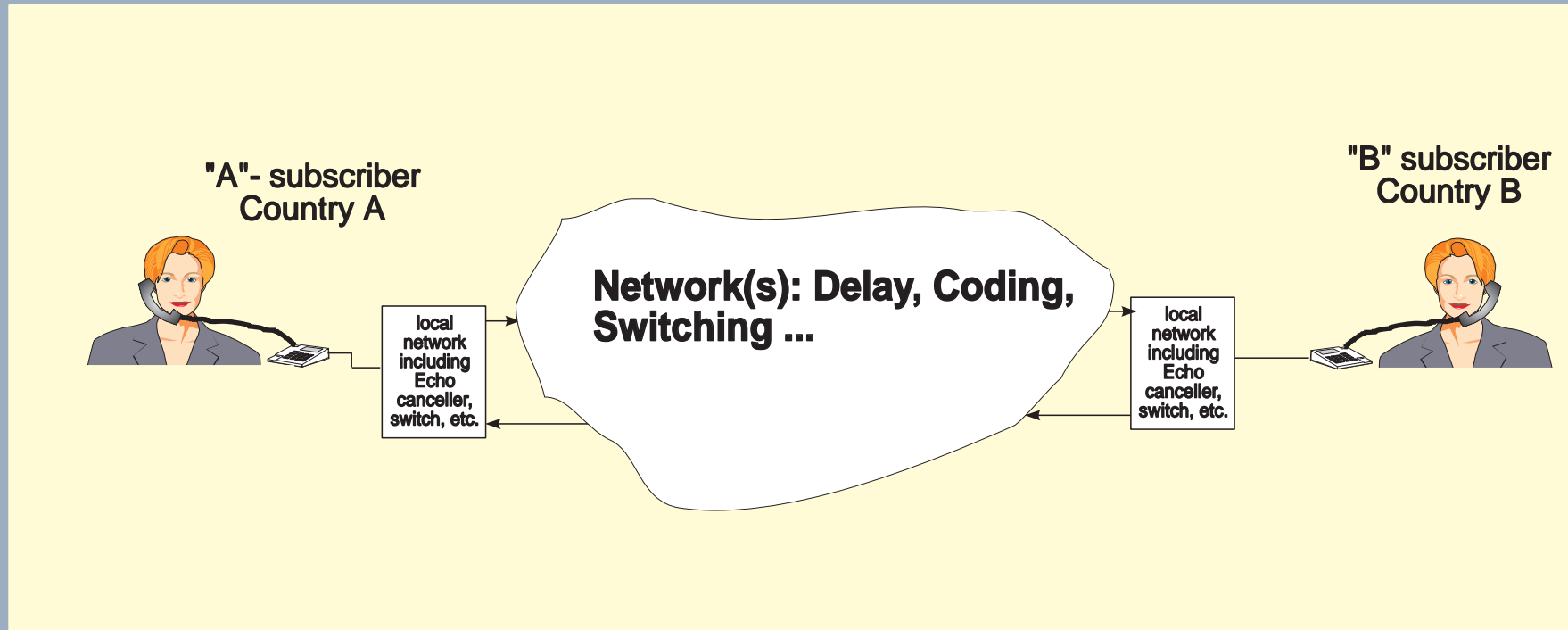

End to End Speech Quality
=
Mouth to Ear Speech Quality

Outline

- Speech Quality: Basics**
- Traditional Instrumental Measures and Their Relationship to Speech Quality**
- Additional Objective Measures**
- The HEAD acoustics Concept: "Listen and Analyse"**

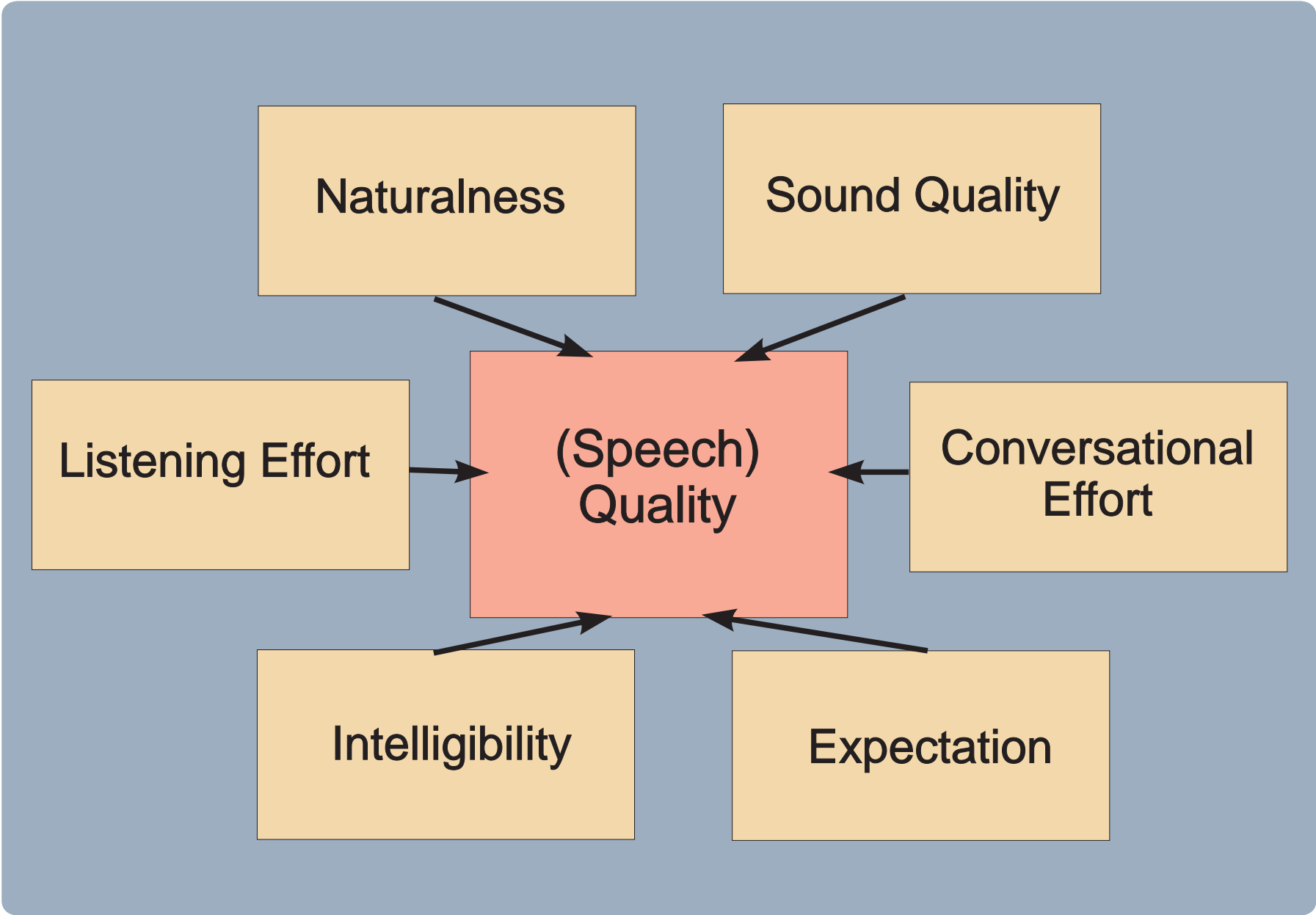

Outline

- **Speech Quality: Basics**
- **Traditional Instrumental Measures and Their Relationship to Speech Quality**
- **Additional Objective Measures**
- **The HEAD acoustics Concept: "Listen and Analyse"**

Influences and Purpose of Tests

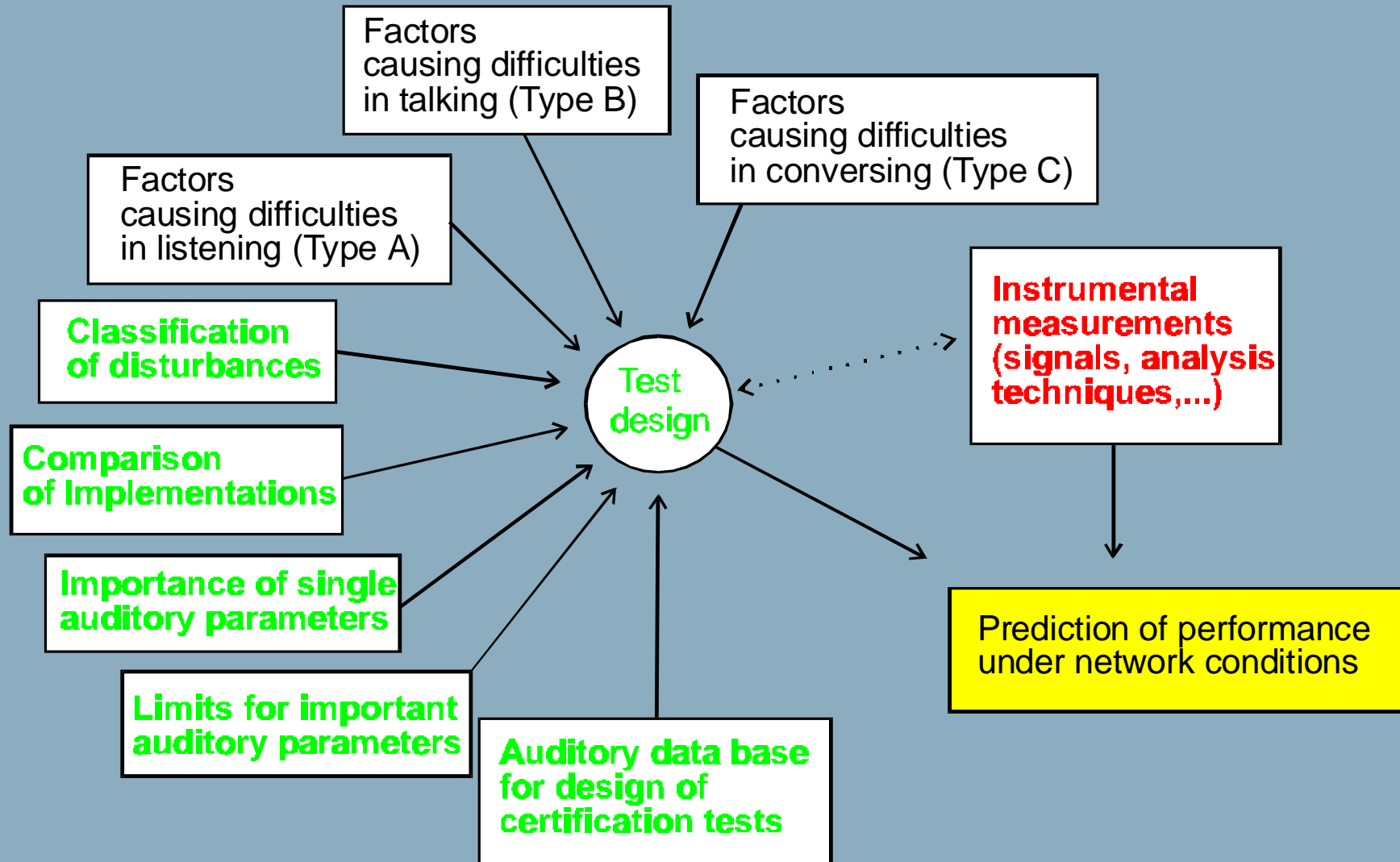

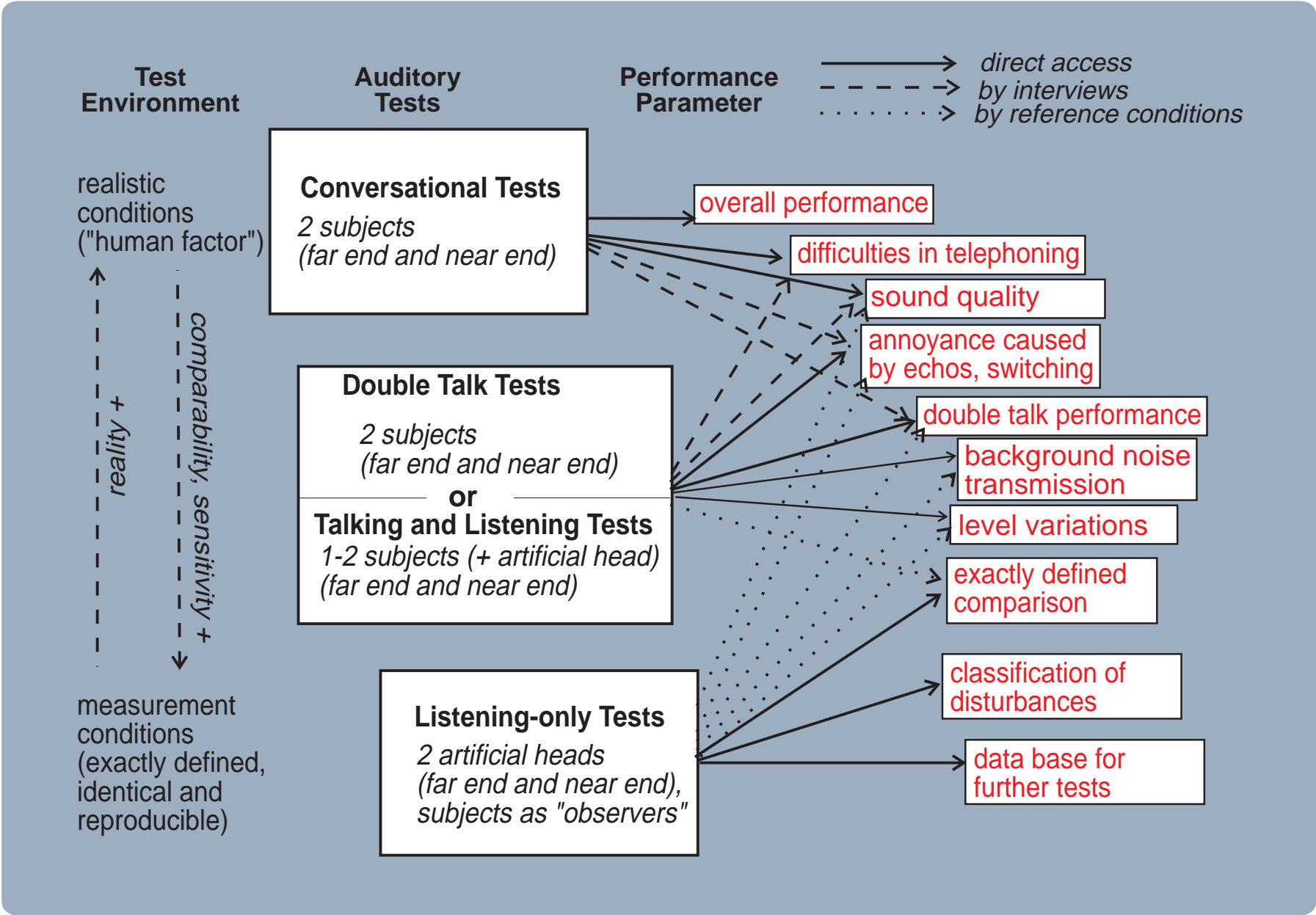

Auditory Evaluation

Conversational Tests

Global Quality Parameter:

- Overall Quality
- Dialogue Capability
- Double Talk Capability
- (- Sound Quality)

Double Talk Tests

Double Talk Parameter:

- Double Talk Capability
- Completeness of Speech Transmission
- Loudness During Double Talk
- Echo Level
- Echo Characteristics
- Sound Quality
- Transmission of Background Noise

Listening Tests

Further Specialized Parameter:

- Overall Quality
- Sound Quality
- Completeness of Speech Transmission
- Disturbance Caused by Echoes
- Variation of Loudness
- Level Differences Single/Double Talk
- Switching Characteristics

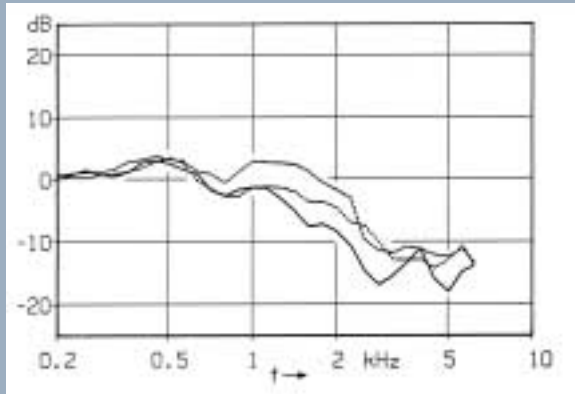

- 1 Signal (voice)
- 2 Noise, transmission noise and room noise
- 3 Noise, sidetone coupling
- 4 Noise, acoustical sidetone
- 5 Noise, structure borne
- 6 Noise, bone conduction
- 7 Noise, coupled to ear not covered by the handset

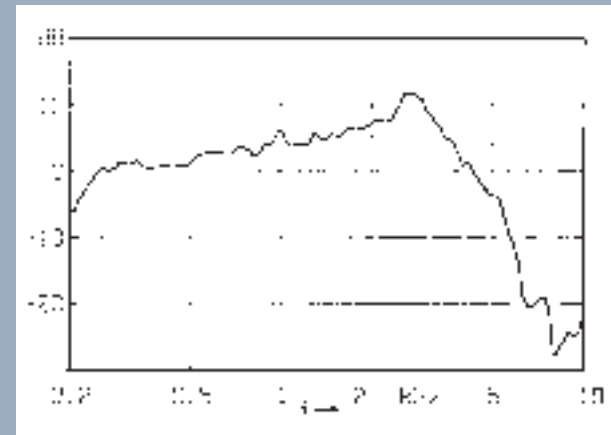
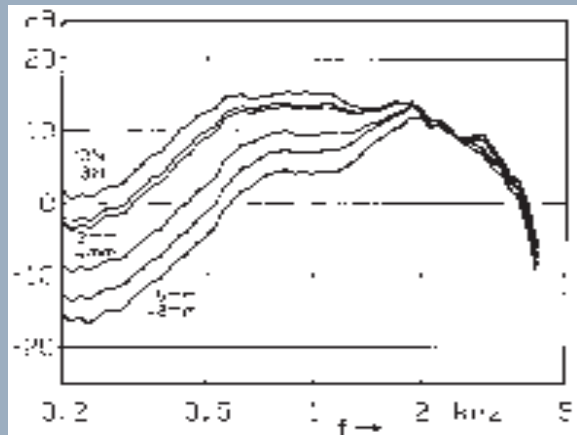
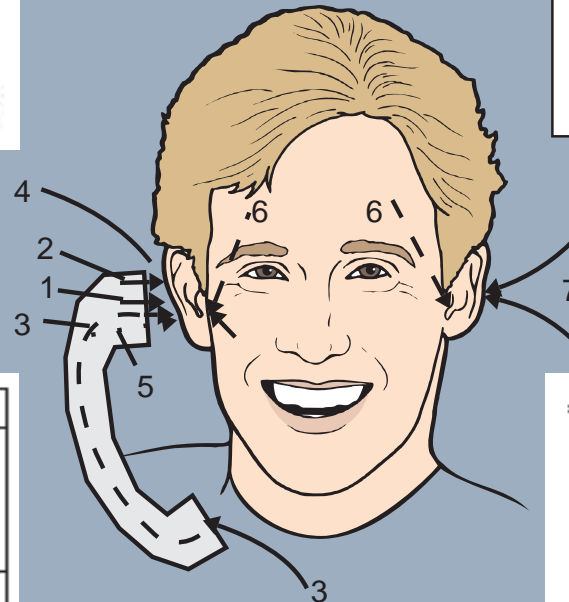

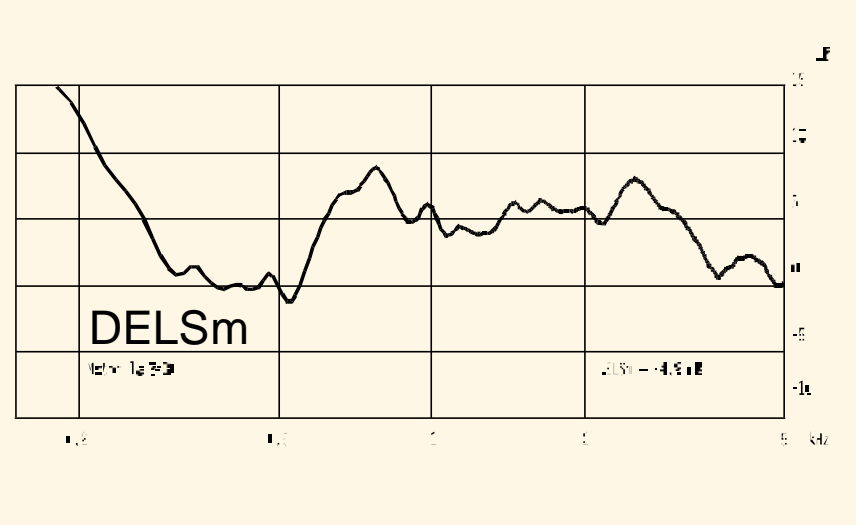
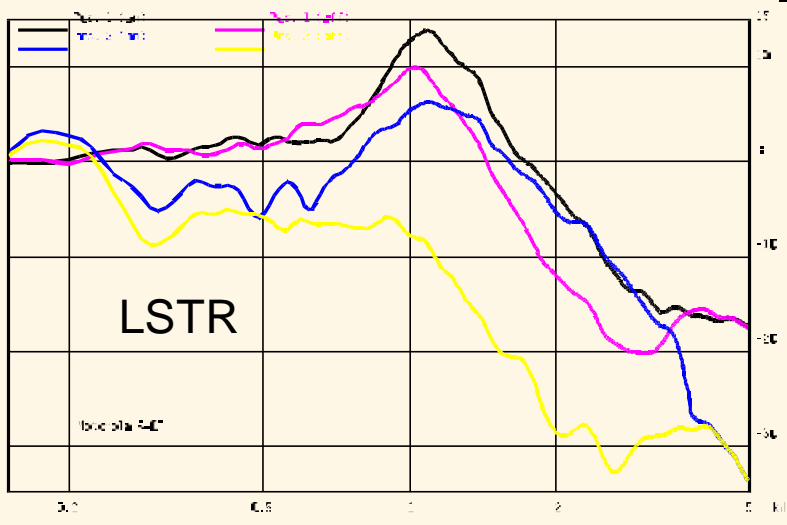
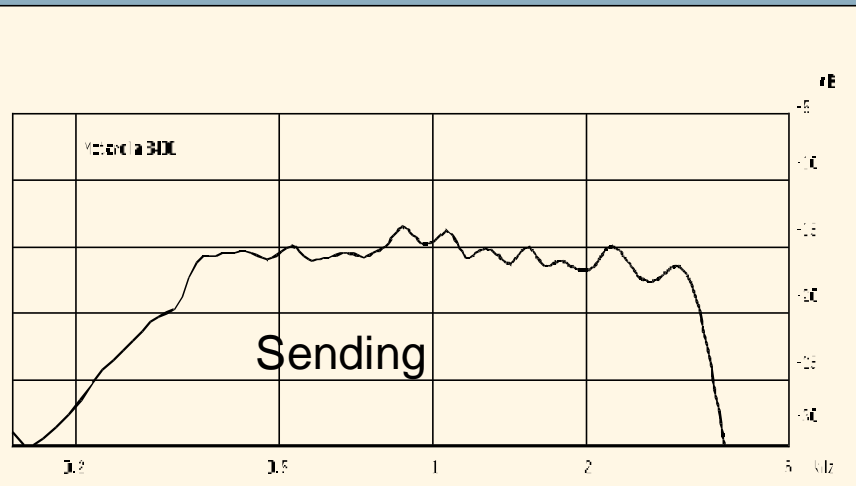
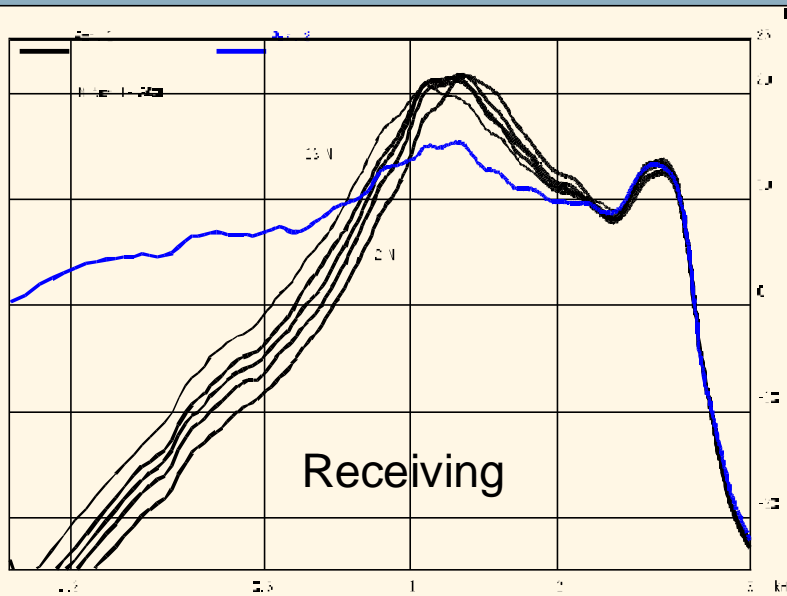

Influence of Masking with the Example of Typical Terminal Transfer Characteristics, Perception of Noise Components

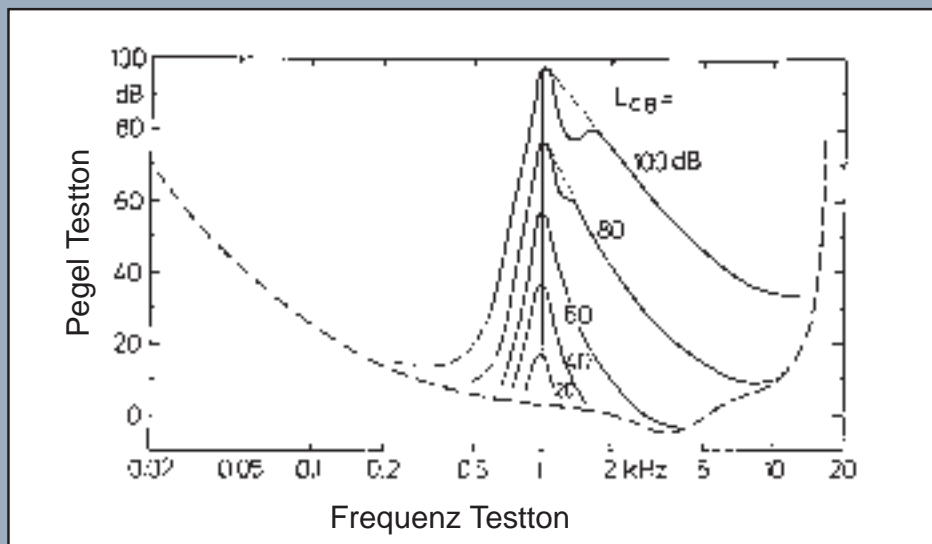
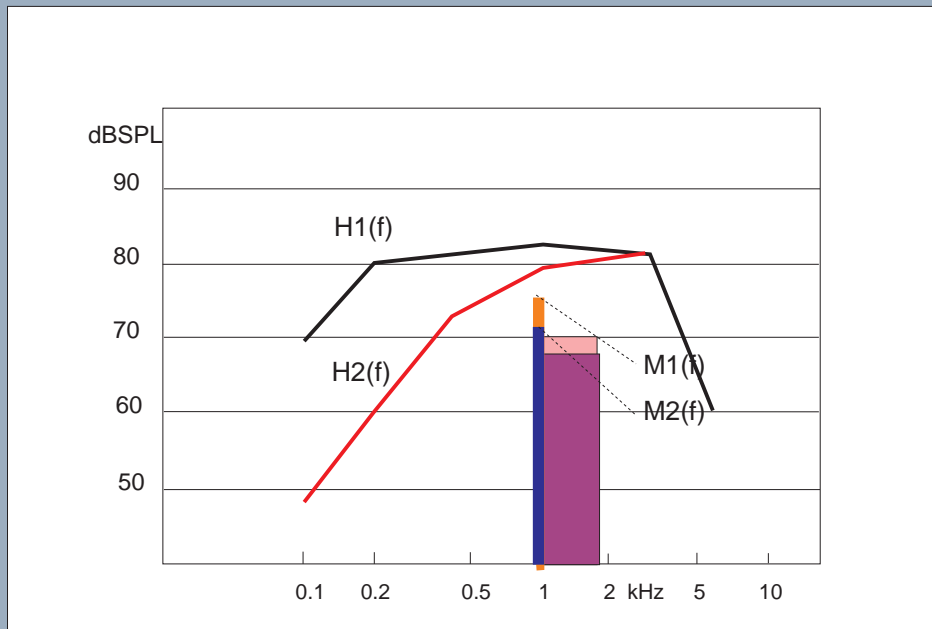

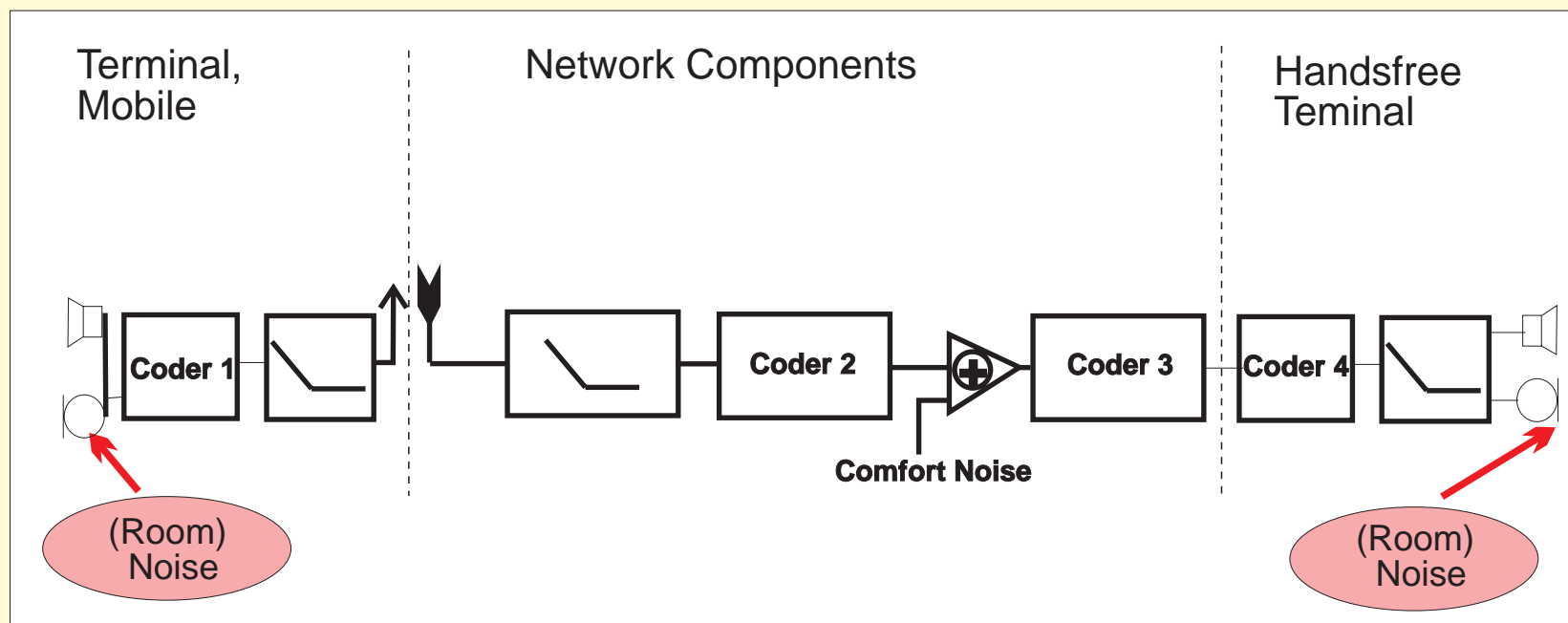

**Example of Interaction Terminal/Network Components
(only one way transmission):**

- Noise and Addition of Comfort Noise
- Concatenation of Switching
- Speech Detection and Noise
- Speech Coding, Cascaded, with Various Types of Noise

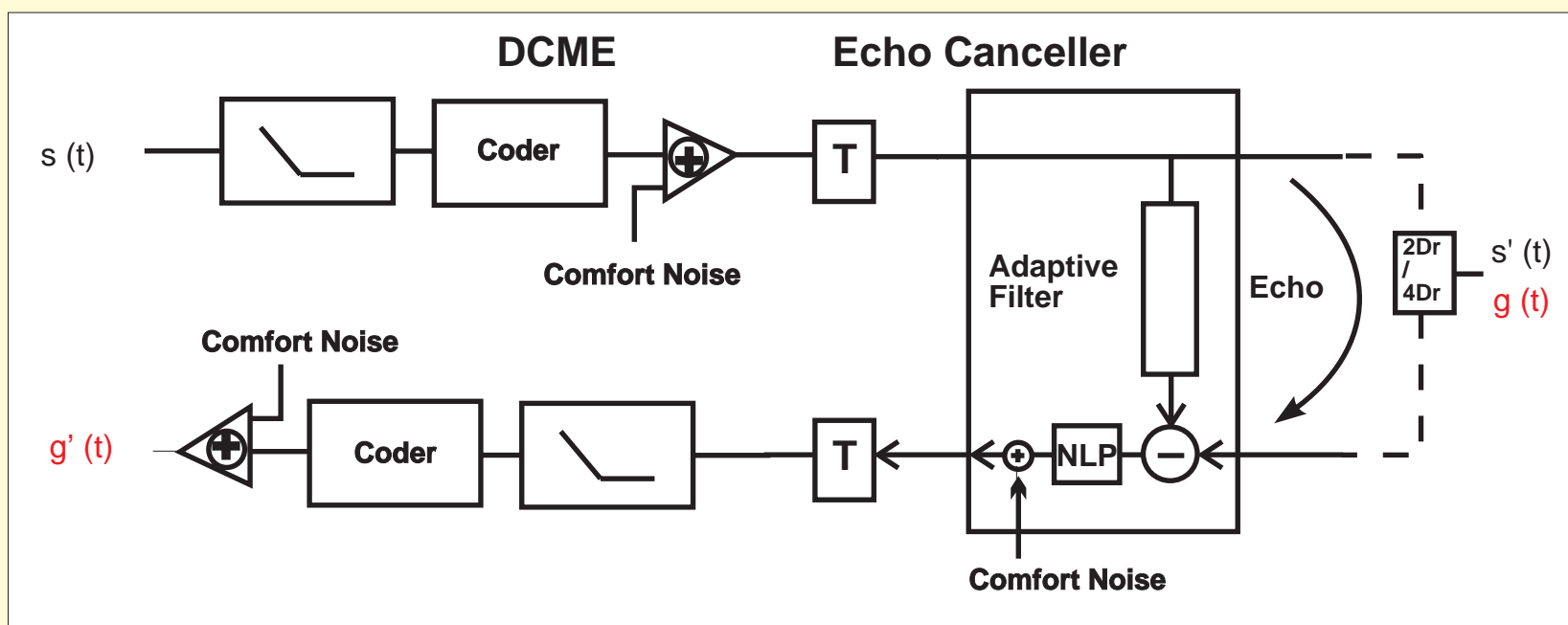

Example DCME and Echo Canceller:

- Addition of very Comfort Noise (Echo Signal as well)
- Concatenation of Switching (Echo Signal as well)
- Double Talk Detection

Outline

- **Speech Quality: Basics**
- **Traditional Instrumental Measures and Their Relationship to Speech Quality**
- **Additional Objective Measures**
- **The HEAD acoustics Concept: "Listen and Analyse"**

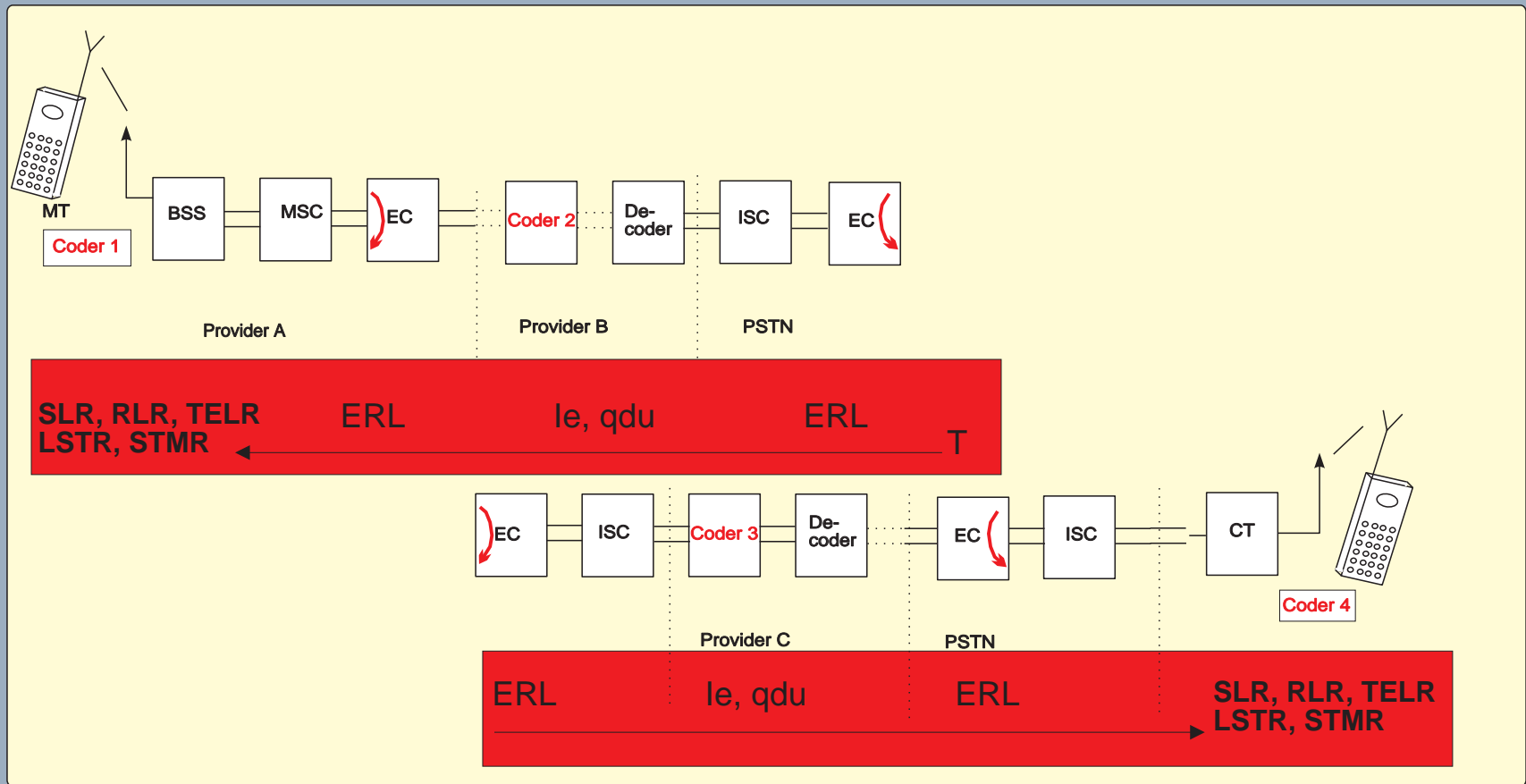

- BSS - Base Station System (Basis Station)
- MSC - Mobil Switching Center (Vermittlungseinrichtung Mobilfunknetz)
- EC - Echo Canceller (Echokompensator)
- ISC - International Switching Center (Öffentliches Fernnetz)
- PSTN - Public Switched Telephone Network (Öffentliches Fernnetz)
- CT - Cordless Telephone (Schnurlos-Telefon)
- MT - Mobile Telephone (Mobiltelefon)

Measurement Signals:

- Sine/Noise
- CS Signals
- Artificial Voice
- Speech

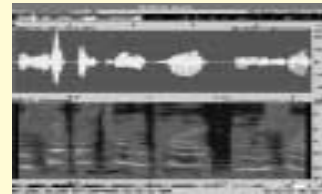
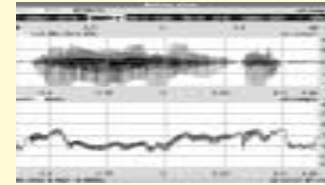
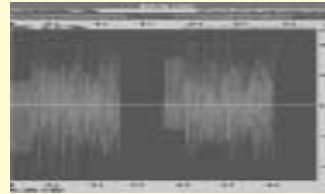

Measurement Parameter:

- Transfer Characteristics (Depending on Level and Situation)
- Switching Characteristics
- Distorsion Characteristics

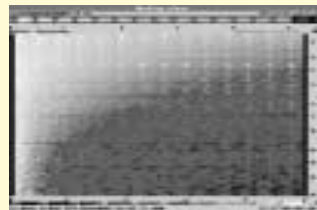
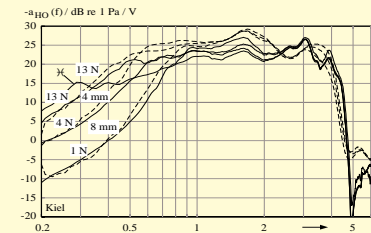

Instrumental Measures based on Hearing Models:

Modelling of the Results of Auditory Tests by Comparison of Reference Speech Signal with Processed Speech Signals

Typical Processing Steps (Schematic):

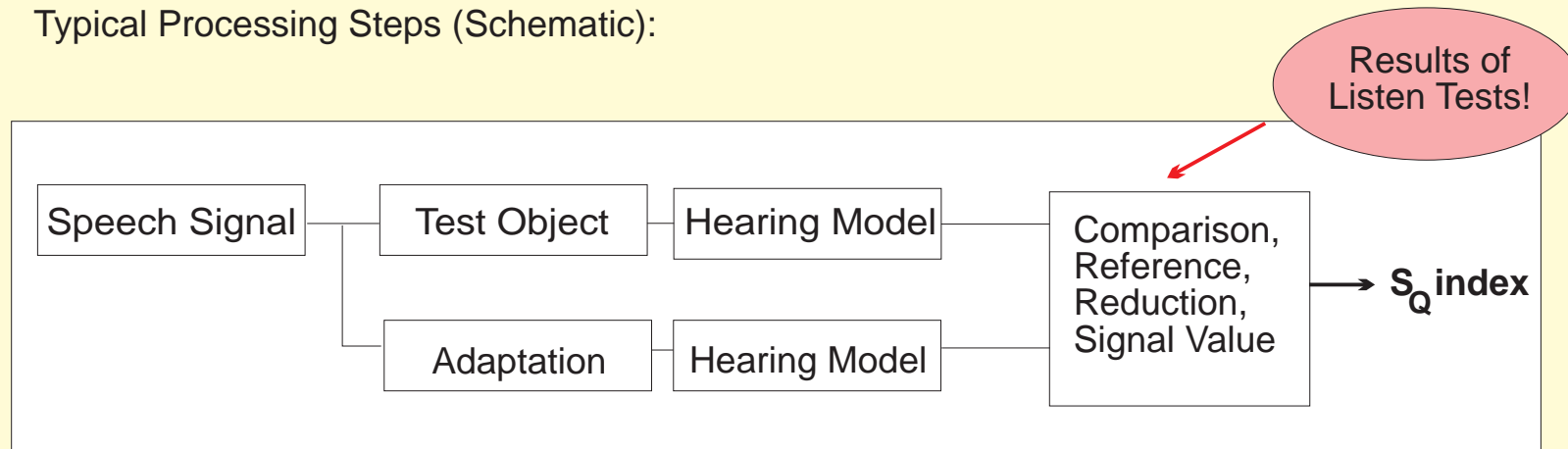

Realisations:

- Spectral Distance- and Comparison Measures
- PQSM (P. 861)
- TOSQA
- NMR ...

“Traditional” Instrumental Measurements, Single Talk Situation:

- Transfer Function
 - Loudness Ratings
 - Distortion
 - System-Dynamic
 - System-Linearity
-
- Sensitivity against Room Noise
 - Switching Characteristics

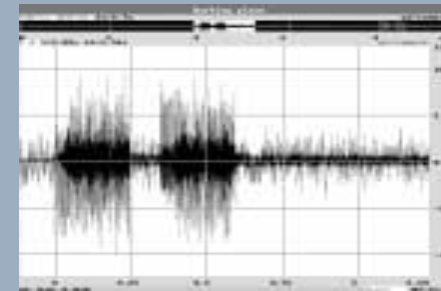
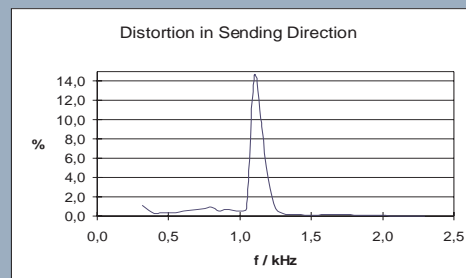
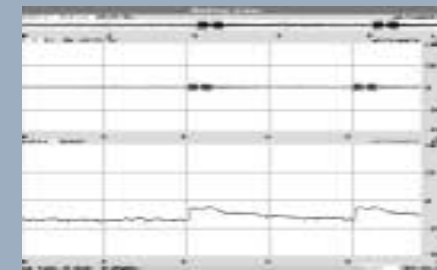
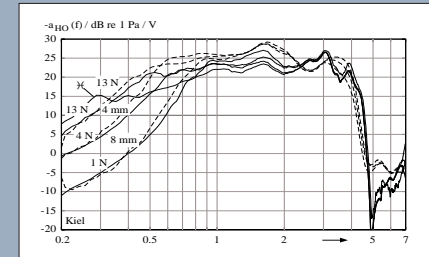
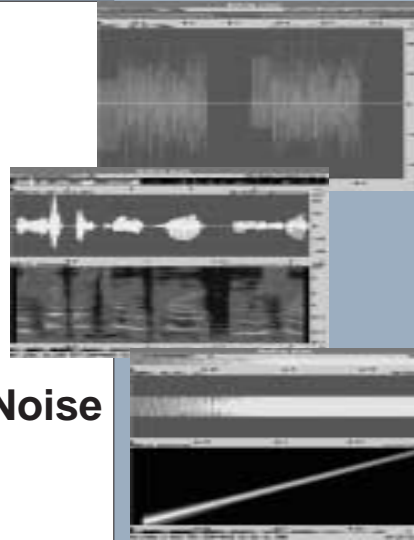

Outline

- **Speech Quality: Basics**
- **Traditional Instrumental Measures and Their Relationship to Speech Quality**
- **Additional Objective Measures**
- **The HEAD acoustics Concept: "Listen and Analyse"**

Instrumental Measurements, Double Talk Situation:

- Transfer Function During Double Talk
 - Loudness Ratings
 - Distortion
 - System-Dynamic
 - System-Linearity
-
- Sensitivity against Room Noise
 - Transmission Characteristics for Room Noise
-
- **Switching and Echo Characteristics**

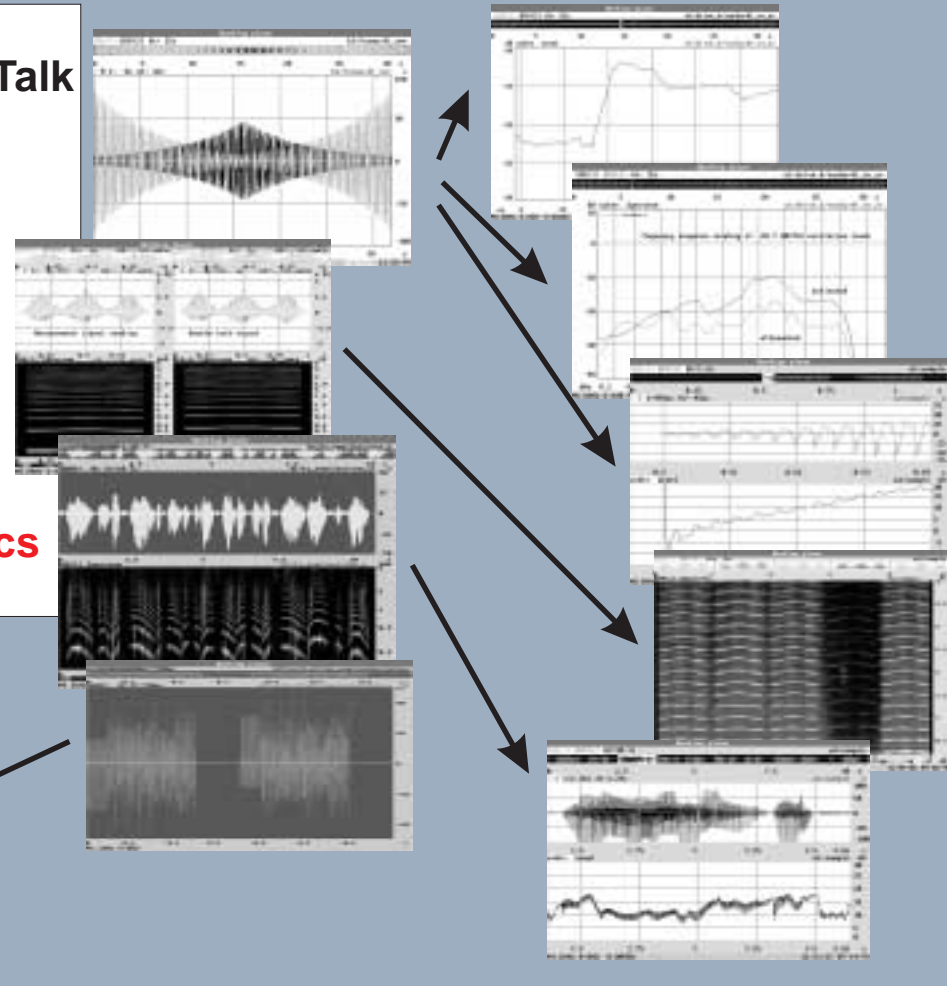

Outline

- **Speech Quality: Basics**
- **Traditional Instrumental Measures and Their Relationship to Speech Quality**
- **Additional Objective Measures**
- **The HEAD acoustics Concept: "Listen and Analyse"**

End to End Recordings, Possible Measurement Arrangement

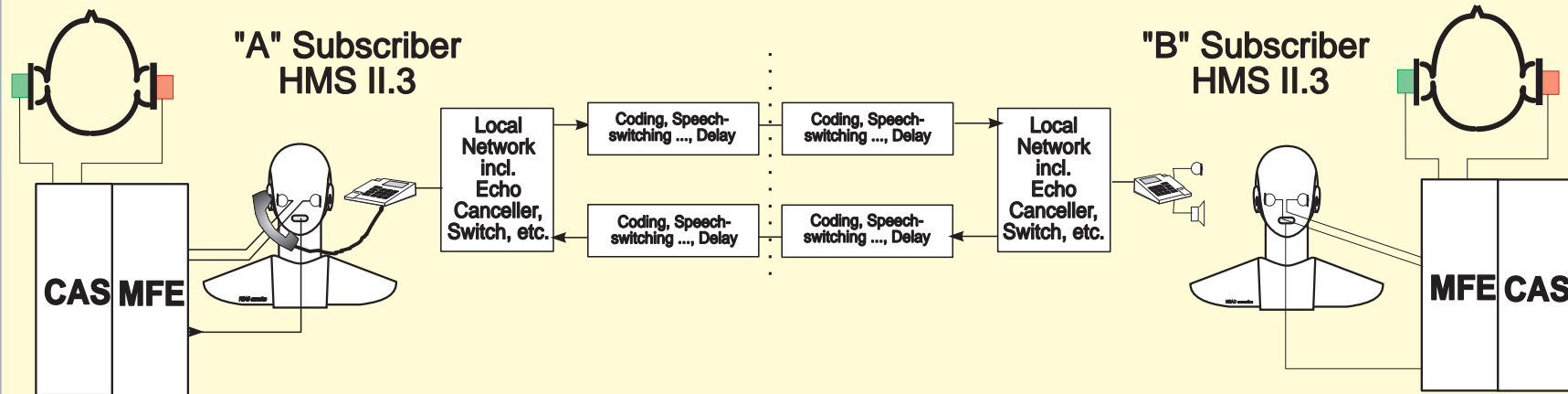

Measurement sequence near end (artificial head): A-subscriber

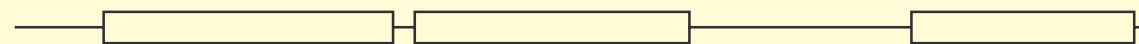

Measurement sequence far end (artificial head): B-subscriber



___ double talk ___ single talk A-subscr. _ single talk B-subscr. _ double talk ___

t ---->

Measurement signals: CS-Signals, Artificial Voice and Speech

Measurement Arrangement for Determining the Transfer Characteristics End to End

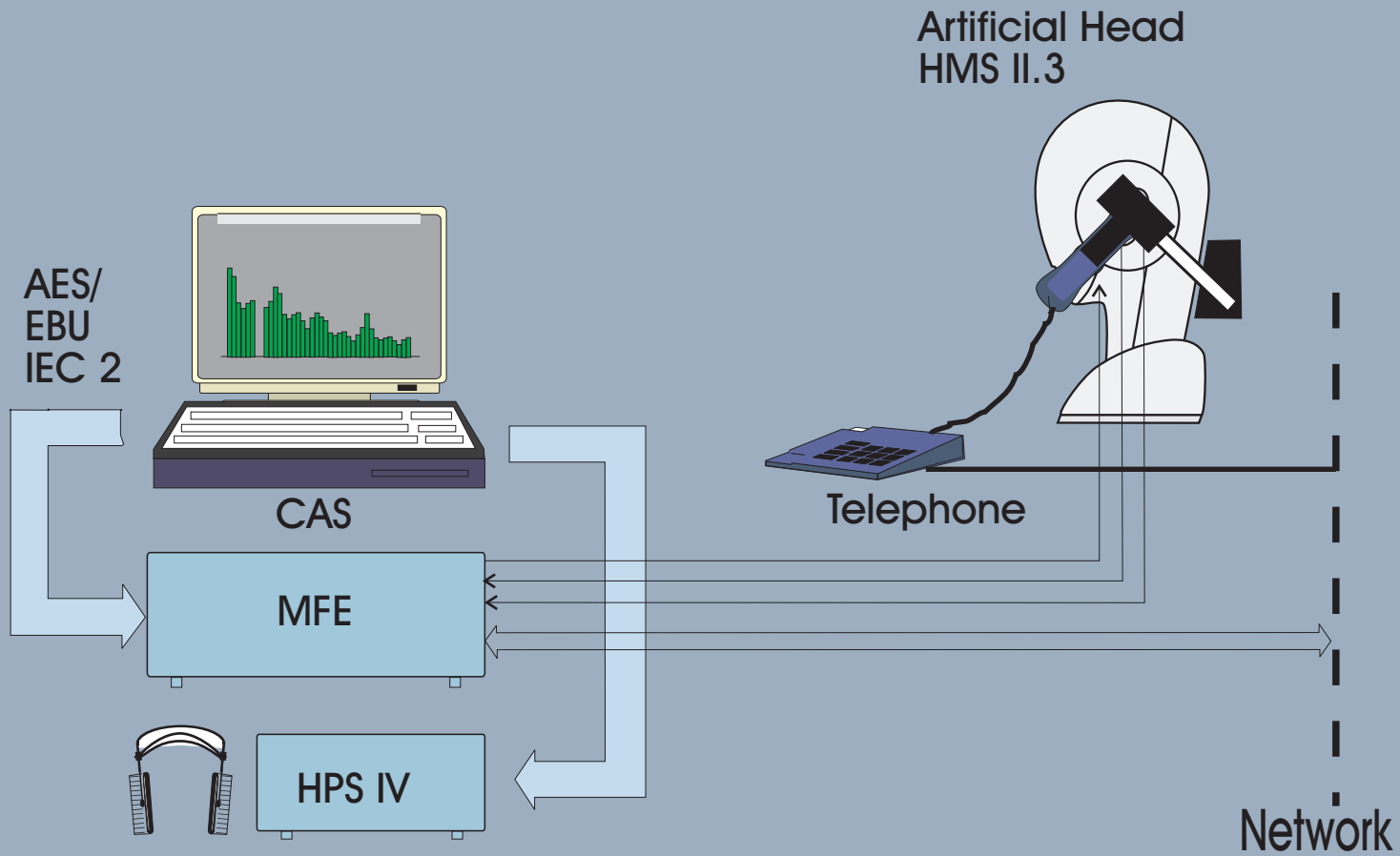

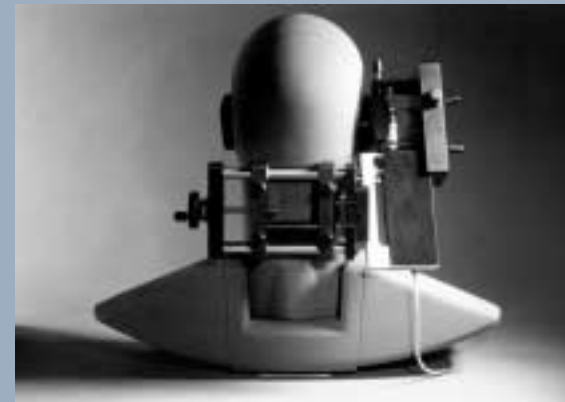

System Components

For further information please contact:

HEAD acoustics GmbH

Ebertstraße 30a

D- 52134 Herzogenrath

Tel: + 49/2407-5770

Fax: + 49/2407-57799

See also our web page:

<http://www.head-acoustics.de>