



**Ground-based UHF radio transmitters,
receivers and transceivers for the UHF
aeronautical mobile service using amplitude modulation;
Harmonised Standard ~~covering the essential requirements for~~
access to radio spectrum
~~of article 3.2 of Directive 2014/53/EU~~**

Reference

REN/ERM-TGAERO-5061

Keywords

aeronautical, AM, DSB, harmonised standard,
radio, testing, UHF

ETSI

650 Route des Lucioles
F-06921 Sophia Antipolis Cedex - FRANCE

Tel.: +33 4 92 94 42 00 Fax: +33 4 93 65 47 16

Siret N° 348 623 562 00017 - NAF 742 C
Association à but non lucratif enregistrée à la
Sous-Préfecture de Grasse (06) N° 7803/88

Important notice

The present document can be downloaded from:

<http://www.etsi.org/standards-search>

The present document may be made available in electronic versions and/or in print. The content of any electronic and/or print versions of the present document shall not be modified without the prior written authorization of ETSI. In case of any existing or perceived difference in contents between such versions and/or in print, the only prevailing document is the print of the Portable Document Format (PDF) version kept on a specific network drive within ETSI Secretariat.

Users of the present document should be aware that the document may be subject to revision or change of status.

Information on the current status of this and other ETSI documents is available at

<https://portal.etsi.org/TB/ETSIDeliverableStatus.aspx>

If you find errors in the present document, please send your comment to one of the following services:

<https://portal.etsi.org/People/CommitteeSupportStaff.aspx>

Copyright Notification

No part may be reproduced or utilized in any form or by any means, electronic or mechanical, including photocopying and microfilm except as authorized by written permission of ETSI.

The content of the PDF version shall not be modified without the written authorization of ETSI.

The copyright and the foregoing restriction extend to reproduction in all media.

© ETSI 2018.

All rights reserved.

DECT™, PLUGTESTS™, UMTS™ and the ETSI logo are trademarks of ETSI registered for the benefit of its Members.

3GPP™ and LTE™/LTE™ are trademarks of ETSI registered for the benefit of its Members and of the 3GPP Organizational Partners.

oneM2M logo is protected for the benefit of its Members.

GSM® and the GSM logo are trademarks registered and owned by the GSM Association.

Contents

| | |
|---|----|
| Intellectual Property Rights | 6 |
| Foreword..... | 6 |
| Modal verbs terminology | 6 |
| 1 Scope | 7 |
| 2 References | 7 |
| 2.1 Normative references | 7 |
| 2.2 Informative references | 7 |
| 3 Definitions and abbreviations..... | 8 |
| 3.1 Definitions | 8 |
| 3.2 Abbreviations..... | 8 |
| 4 General requirements | 9 |
| 4.1 Frequency control | 9 |
| 4.2 Controls and indicators | 9 |
| 4.3 Class of emission and modulation characteristics..... | 9 |
| 4.4 Warm up | 9 |
| 4.5 Protection of the transmitter..... | 9 |
| 4.5.1 Definition | 9 |
| 4.5.2 Method of measurement..... | 9 |
| 4.5.3 Requirement | 9 |
| 5 General conditions of measurement | 10 |
| 5.1 Transmitter test signal arrangement..... | 10 |
| 5.1.1 Coaxial termination | 10 |
| 5.1.2 Signal sources..... | 10 |
| 5.1.3 Normal test signal | 10 |
| 5.2 Receiver test signal arrangement | 10 |
| 5.2.1 Test signal sources | 10 |
| 5.2.2 Nominal frequency..... | 10 |
| 5.2.3 Normal test signal | 10 |
| 5.2.4 Squelch..... | 10 |
| 5.2.5 Normal audio output power..... | 10 |
| 5.2.6 Audio AGC | 10 |
| 5.3 Test channels | 10 |
| 5.4 Environmental profile | 11 |
| 5.5 Test power source | 11 |
| 5.6 Normal test conditions | 11 |
| 5.6.1 Normal temperature and humidity | 11 |
| 5.6.2 Normal power sources..... | 11 |
| 5.6.2.1 Mains voltage and frequency..... | 11 |
| 5.6.2.2 Other power sources | 11 |
| 5.7 Extreme test conditions..... | 11 |
| 5.7.1 Extreme temperatures..... | 11 |
| 5.7.2 Extreme values of test power sources | 12 |
| 5.7.2.1 Mains voltage | 12 |
| 5.7.2.2 Other power sources | 12 |
| 5.8 Performance test | 12 |
| 5.9 Environmental tests..... | 12 |
| 5.9.1 General | 12 |
| 5.9.2 Procedure for tests at extreme temperatures | 12 |
| 5.9.3 Temperature tests | 13 |
| 5.9.3.1 General | 13 |
| 5.9.3.2 High temperature | 13 |
| 5.9.3.3 Low temperature..... | 13 |
| 6 Transmitter | 13 |
| 6.1 General..... | 13 |

| | | |
|---------|---|----|
| 6.2 | Frequency error..... | 13 |
| 6.2.1 | Definition | 13 |
| 6.2.2 | Method of measurement..... | 13 |
| 6.2.3 | Limits | 14 |
| 6.3 | Carrier power | 14 |
| 6.3.1 | Definitions..... | 14 |
| 6.3.2 | Method of measurement..... | 14 |
| 6.3.3 | Limits | 14 |
| 6.4 | Amplitude modulation characteristic | 14 |
| 6.4.1 | Modulation depth | 14 |
| 6.4.1.1 | Definitions | 14 |
| 6.4.1.2 | Method of measurement | 15 |
| 6.4.1.3 | Limits..... | 15 |
| 6.4.2 | Modulation compression | 15 |
| 6.4.2.1 | Definition..... | 15 |
| 6.4.2.2 | Method of measurement | 15 |
| 6.4.2.3 | Limits..... | 15 |
| 6.4.3 | Amplitude modulation distortion | 15 |
| 6.4.3.1 | Definition..... | 15 |
| 6.4.3.2 | Method of measurement | 15 |
| 6.4.3.3 | Limits..... | 16 |
| 6.4.4 | Audio frequency response | 16 |
| 6.4.4.1 | Definition..... | 16 |
| 6.4.4.2 | Method of measurement | 16 |
| 6.4.4.3 | Limits..... | 16 |
| 6.5 | Adjacent channel power..... | 16 |
| 6.5.1 | Definition | 16 |
| 6.5.2 | Measurement | 16 |
| 6.5.3 | Limits | 17 |
| 6.6 | Broadband noise | 17 |
| 6.6.1 | Definition | 17 |
| 6.6.2 | Method of measurement..... | 17 |
| 6.6.3 | Limit..... | 18 |
| 6.7 | Conducted spurious emissions (TX)..... | 18 |
| 6.7.1 | Definition | 18 |
| 6.7.2 | Method of measurement..... | 18 |
| 6.7.3 | Limits | 18 |
| 6.8 | Intermodulation attenuation | 19 |
| 6.8.1 | Definition | 19 |
| 6.8.2 | Method of measurement..... | 19 |
| 6.8.3 | Limits | 20 |
| 6.9 | RF power attack time and release time | 20 |
| 6.9.1 | Definitions..... | 20 |
| 6.9.2 | Method of measurement..... | 21 |
| 6.9.2.1 | Attack time | 21 |
| 6.9.2.2 | Release time..... | 21 |
| 6.9.3 | Limits | 21 |
| 6.10 | Keying Transient frequency behaviour of the transmitter | 21 |
| 6.10.1 | Definition | 21 |
| 6.10.2 | Method of measurement..... | 21 |
| 6.10.3 | Limits | 22 |
| 6.11 | Cabinet Radiation (TX) | 22 |
| 7 | Receiver..... | 23 |
| 7.1 | Sensitivity | 23 |
| 7.1.1 | Definition | 23 |
| 7.1.2 | Method of measurement..... | 23 |
| 7.1.3 | Limits | 23 |
| 7.2 | Effective acceptance bandwidth | 23 |
| 7.2.1 | Definition | 23 |
| 7.2.2 | Method of measurement..... | 23 |
| 7.2.3 | Limits | 23 |

| | | |
|-------------------------------|---|-----------|
| 7.3 | Adjacent channel rejection..... | 24 |
| 7.3.1 | Definition | 24 |
| 7.3.2 | Method of measurement..... | 24 |
| 7.3.3 | Limits | 24 |
| 7.4 | Spurious response rejection | 24 |
| 7.4.1 | Definition | 24 |
| 7.4.2 | Introduction to the method of measurement..... | 24 |
| 7.4.3 | Method of search of the limited frequency range..... | 25 |
| 7.4.4 | Method of measurement..... | 25 |
| 7.4.5 | Limit..... | 26 |
| 7.5 | Intermodulation response rejection..... | 26 |
| 7.5.1 | Definition | 26 |
| 7.5.2 | Method of measurement..... | 26 |
| 7.5.3 | Limit..... | 26 |
| 7.6 | Blocking or desensitization..... | 26 |
| 7.6.1 | Definition | 26 |
| 7.6.2 | Method of measurement..... | 27 |
| 7.6.3 | Limit..... | 27 |
| 7.7 | Conducted spurious emissions | 27 |
| 7.7.1 | Definition | 28 |
| 7.7.2 | Method of measuring the power level..... | 28 |
| 7.7.3 | Limits | 28 |
| 7.8 | Cross modulation rejection | 28 |
| 7.8.1 | Definition | 28 |
| 7.8.2 | Method of measurement..... | 28 |
| 7.8.3 | Limits | 29 |
| 7.9 | Receiver dynamic range..... | 29 |
| 7.9.1 | Definition | 29 |
| 7.9.2 | Method of measurement..... | 29 |
| 7.9.3 | Limit..... | 29 |
| 7.10 | Cabinet Radiation (RX) | 29 |
| 8 | Testing for compliance with technical requirements..... | 29 |
| 8.1 | Environmental conditions for testing..... | 29 |
| 8.2 | Interpretation of the measurement results | 29 |
| Annex A (informative): | Relationship between the present document and the essential requirements of Directive 2014/53/EU | 31 |
| Annex B (normative): | Specification for adjacent channel power measurement arrangements..... | 33 |
| B.1 | Power measuring receiver specification..... | 33 |
| B.1.1 | General..... | 33 |
| B.1.2 | IF filter | 33 |
| B.1.3 | Attenuation indicator | 35 |
| B.1.4 | RMS value indicator | 35 |
| B.1.5 | Oscillator and amplifier | 35 |
| Annex C (informative): | Auxiliary cables..... | 36 |
| Annex D (informative): | Change history | 37 |
| History | | 38 |

Intellectual Property Rights

Essential patents

IPRs essential or potentially essential to normative deliverables may have been declared to ETSI. The information pertaining to these essential IPRs, if any, is publicly available for **ETSI members and non-members**, and can be found in ETSI SR 000 314: "*Intellectual Property Rights (IPRs); Essential, or potentially Essential, IPRs notified to ETSI in respect of ETSI standards*", which is available from the ETSI Secretariat. Latest updates are available on the ETSI Web server (<https://ipr.etsi.org/>).

Pursuant to the ETSI IPR Policy, no investigation, including IPR searches, has been carried out by ETSI. No guarantee can be given as to the existence of other IPRs not referenced in ETSI SR 000 314 (or the updates on the ETSI Web server) which are, or may be, or may become, essential to the present document.

Trademarks

The present document may include trademarks and/or tradenames which are asserted and/or registered by their owners. ETSI claims no ownership of these except for any which are indicated as being the property of ETSI, and conveys no right to use or reproduce any trademark and/or tradename. Mention of those trademarks in the present document does not constitute an endorsement by ETSI of products, services or organizations associated with those trademarks.

Foreword

This Harmonised European Standard (EN) has been produced by ETSI Technical Committee Electromagnetic compatibility and Radio spectrum Matters (ERM).

The present document has been prepared under the Commission's standardisation request C(2015) 5376 final [i.7] to provide one voluntary means of conforming to the essential requirements of Directive 2014/53/EU on the harmonisation of the laws of the Member States relating to the making available on the market of radio equipment and repealing Directive 1999/5/EC [i.1].

Once the present document is cited in the Official Journal of the European Union under that Directive, compliance with the normative clauses of the present document given in table A.1 confers, within the limits of the scope of the present document, a presumption of conformity with the corresponding essential requirements of that Directive and associated EFTA regulations.

| National transposition dates | |
|--|-------------------|
| Date of adoption of this EN: | 19 June 2018 |
| Date of latest announcement of this EN (doa): | 30 September 2018 |
| Date of latest publication of new National Standard or endorsement of this EN (dop/e): | 31 March 2019 |
| Date of withdrawal of any conflicting National Standard (dow): | 31 March 2019 |

Modal verbs terminology

In the present document "**shall**", "**shall not**", "**should**", "**should not**", "**may**", "**need not**", "**will**", "**will not**", "**can**" and "**cannot**" are to be interpreted as described in clause 3.2 of the [ETSI Drafting Rules](#) (Verbal forms for the expression of provisions).

"**must**" and "**must not**" are **NOT** allowed in ETSI deliverables except when used in direct citation.

1 Scope

The present document specifies technical characteristics and methods of measurements for DSB AM ground based transmitters, receivers and transceivers operating in all or any part of the aeronautical frequency band between 225 MHz and 399,975 MHz.

NOTE: ~~The relationship between the present document covers the and~~ essential requirements of article 3.2 of Directive 2014/53/EU [i.1.1] ~~under the conditions identified is given~~ in annex A.

In addition to the present document, other ENs that specify technical requirements in respect of essential requirements under other parts of article 3 of the Directive 2014/53/EU [i.1] as well as essential requirements under the Single European Sky (SES) Interoperability Regulation No 552/2004 [i.3] and related implementing rules and/or essential requirements under the EASA basic Regulation No 216/2008 [i.5] as amended by Regulation No 1108/2009 [i.6] may apply to equipment within the scope of the present document.

2 References

2.1 Normative references

References are specific, identified by date of publication and/or edition number or version number. Only the cited version applies.

Referenced documents which are not found to be publicly available in the expected location might be found at <https://docbox.etsi.org/Reference/>.

NOTE: While any hyperlinks included in this clause were valid at the time of publication, ETSI cannot guarantee their long term validity.

The following referenced documents are necessary for the application of the present document.

- [1] ETSI EN 300 113-1 (V1.7.1) (11-2011): "Electromagnetic compatibility and Radio spectrum Matters (ERM); Land mobile service; Radio equipment intended for the transmission of data (and/or speech) using constant or non-constant envelope modulation and having an antenna connector; Part 1: Technical characteristics and methods of measurement".
- [2] Recommendation ITU-T O.41 (10-1994): "Psophometer for use on telephone-type circuits".

2.2 Informative references

References are either specific (identified by date of publication and/or edition number or version number) or non-specific. For specific references, only the cited version applies. For non-specific references, the latest version of the referenced document (including any amendments) applies.

NOTE: While any hyperlinks included in this clause were valid at the time of publication, ETSI cannot guarantee their long term validity.

The following referenced documents are not necessary for the application of the present document but they assist the user with regard to a particular subject area.

- [i.1] Directive 2014/53/EU of the European Parliament and of the Council of 16 April 2014 on the harmonisation of the laws of the Member States relating to the making available on the market of radio equipment and repealing Directive 1999/5/EC.
- [i.2] ETSI TR 100 028 (all parts) (V1.4.1): "Electromagnetic compatibility and Radio spectrum Matters (ERM); Uncertainties in the measurement of mobile radio equipment characteristics".
- [i.3] Regulation (EC) 552/2004 of the European Parliament and Council of 10 March 2004 on the interoperability of the European Air Traffic Management network (the interoperability Regulation), OJEU L96, 31.03.2004, p. 26-42 as amended by Regulation (EC) 1070/2009 of the European Parliament and of the Council of 21 October 2009, OJEU L300/34, 14/11/2009.

- [i.4] ETSI TR 100 028-2 (V1.4.1): "Electromagnetic compatibility and Radio spectrum Matters (ERM); Uncertainties in the measurement of mobile radio equipment characteristics; Part 2".
- [i.5] Regulation (EC) 216/2008 of the European Parliament and of the Council of 20 February 2008 on common rules in the field of civil aviation and establishing a European Aviation Safety Agency, and repealing Council Directive 91/670/EEC, Regulation (EC) No 1592/2002 and Directive 2004/36/EC.
- [i.6] Regulation (EC) No 1108/2009 of the European Parliament and of the Council of 21 October 2009 amending Regulation (EC) No 216/2008 in the field of aerodromes, air traffic management and air navigation services and repealing Directive 2006/23/EC.
- [i.7] Commission Implementing Decision C(2015) 5376 final of 4.8.2015 on a standardisation request to the European Committee for Electrotechnical Standardisation and to the European Telecommunications Standards Institute as regards radio equipment in support of Directive 2014/53/EU of the European Parliament and of the Council.

3 Definitions and abbreviations

3.1 Definitions

For the purposes of the present document, the following terms and definitions apply:

aeronautical mobile service: mobile service between aeronautical stations and aircraft stations, or between aircraft stations, in which survival craft stations may participate

conducted measurements: measurements which are made using a direct RF connection to the equipment under test

environmental profile: range of environmental conditions under which equipment within the scope of the present document is required to comply with the provisions of the present document

ground base station: aeronautical station equipment, in the aeronautical mobile service, for use with an external antenna and intended for use at a fixed location

radiated measurements: measurements which involve the measurement of a radiated field

3.2 Abbreviations

For the purposes of the present document, the following abbreviations apply:

| | |
|--------------|--|
| <u>AC</u> | <u>Alternating Current</u> |
| <u>AF</u> | <u>Audio Frequency</u> |
| <u>AGC</u> | <u>Automatic Gain Control</u> |
| <u>AM</u> | <u>Amplitude Modulation</u> |
| <u>BW</u> | <u>Bandwidth</u> |
| <u>dB</u> | <u>decibel</u> |
| <u>DSB</u> | <u>Double Side Band</u> |
| <u>RE</u> | <u>Radio Equipment</u> |
| <u>EASA</u> | <u>European Aviation Safety Agency</u> |
| <u>EC</u> | <u>European Community</u> |
| <u>EFTA</u> | <u>European Free Trade Association</u> |
| <u>EU</u> | <u>European Union</u> |
| <u>IF</u> | <u>Intermediate Frequency</u> |
| <u>ITU-T</u> | <u>International Telecommunication Union - Telecommunication</u> |
| <u>RF</u> | <u>Radio Frequency</u> |
| <u>RMS</u> | <u>Root Mean Square</u> |
| <u>RX</u> | <u>Receive</u> |
| <u>SES</u> | <u>Single European Sky</u> |
| <u>SINAD</u> | <u>Signal In Noise And Distortion</u> |
| <u>TX</u> | <u>Transmit</u> |
| <u>WB</u> | <u>Wideband</u> |

4 General requirements

4.1 Frequency control

25 kHz equipment shall be able to operate on the frequencies 225,000 MHz to 399,975 MHz.

It shall not be possible to transmit while any frequency synthesizer used within the transmitter is out of lock.

It shall not be possible to transmit during channel switching operations.

4.2 Controls and indicators

The equipment shall have the following controls and indicators as a minimum:

- a visual indication that the device is switched on;
- a facility to disable the squelch for test purposes (by local or remote control);
- a visual indication that the carrier is being produced.

The equipment shall also meet the following requirements:

- the user shall not have access to any control which, if unintentionally set, might impair the operating parameters of the equipment.

4.3 Class of emission and modulation characteristics

The equipment shall use Double Side Band (DSB) Amplitude Modulation (AM) full carrier, 6K80A3EJN with 25 kHz channel spacing.

4.4 Warm up

After being switched on the equipment shall meet the requirements of the present document within one minute under normal test conditions (see clause 5.6).

If the equipment includes parts which require to be heated in order to operate correctly (e.g. crystal ovens) a warming-up period of 10 minutes of those parts shall be allowed.

4.5 Protection of the transmitter

4.5.1 Definition

The protection of the transmitter represents the ability of the transmitter to be protected against malfunction due to faults in the antenna system. This shall be the first test applied to a transmitter.

4.5.2 Method of measurement

While the transmitter is transmitting at the rated output power, the antenna port shall first be short-circuited and then open-circuited, in each case for a period of 1 minute. This test shall be performed on 312,5 MHz only.

4.5.3 Requirement

This test shall not result in any damage to the transmitter. After removal of the short-circuit and open-circuit conditions, the transmitter shall be able to operate normally when re-keyed.

5 General conditions of measurement

5.1 Transmitter test signal arrangement

5.1.1 Coaxial termination

When tests are carried out with a coaxial termination, this shall be a non-reactive, non radiating 50 Ω load.

5.1.2 Signal sources

The modulating signals shall be applied to the transmitter through the modulating audio input.

5.1.3 Normal test signal

The normal test signal shall be a 1 kHz sinewave at a level which produces a 30 % amplitude modulation depth, of the transmitter RF output, unless otherwise defined.

5.2 Receiver test signal arrangement

5.2.1 Test signal sources

Test signal sources shall be connected to the receiver input in such a way that the impedance presented to the receiver input is 50 Ω , irrespective of whether one or more test signals are applied to the receiver simultaneously.

5.2.2 Nominal frequency

The nominal frequency of the receiver is the carrier frequency of the selected channel.

5.2.3 Normal test signal

The normal test signal shall be a Double Side Band (DSB) signal with carrier, amplitude modulated with 1 kHz sinewave to a depth of 30 %.

5.2.4 Squelch

Unless otherwise stated the receiver squelch facility shall be made inoperative for the duration of the tests.

5.2.5 Normal audio output power

The rated audio frequency output power is the value stated by the manufacturer to be the maximum power available at the output, for which all the requirements of the present document are met.

The audio frequency output power shall be maintained at 50 % of the rated output in the presence of a desired signal unless otherwise defined.

5.2.6 Audio AGC

When an audio AGC function is provided, this shall be disabled (where possible) unless otherwise stated.

5.3 Test channels

Tests shall be carried out on three frequencies unless otherwise stated:

- 225,000 MHz;
- 312,500 MHz;
- 399,975 MHz.

5.4 Environmental profile

The technical requirements of the present document apply under the environmental profile for operation of the equipment, which shall be declared by the manufacturer, but as a minimum, shall be that specified in the test conditions contained in the present document. The equipment shall comply with all the technical requirements of the present document which are identified as applicable in annex A at all times when operating within the boundary limits of the declared operational environmental profile.

Measurements shall be made under normal test conditions (see clause 5.6) and also, where stated, under extreme test conditions (see clause 5.7).

5.5 Test power source

During testing, the equipment shall be supplied from a test power source capable of producing normal and extreme test voltages.

The internal impedance of the test power source shall be low enough for its effect on the test results to be negligible. For the purpose of testing the power source voltage shall be measured at the input terminals of the equipment.

During testing, the power source voltages shall be maintained within a tolerance of ± 3 % relative to the voltage level at the beginning of each test.

5.6 Normal test conditions

5.6.1 Normal temperature and humidity

The normal temperature and humidity conditions for tests shall be a combination of temperature and humidity within the following ranges:

- temperature: +15 °C to +35 °C;
- relative humidity: 20 % to 75 %.

~~When it is impracticable to carry out the tests under these conditions, a note to this effect, stating the ambient temperature and relative humidity during the tests, shall be added to the test report.~~

5.6.2 Normal power sources

5.6.2.1 Mains voltage and frequency

The normal test voltage for equipment to be connected to the mains shall be the nominal mains voltage.

For the purpose of the present document, the nominal voltage shall be the declared voltage or any of the declared voltages for which the equipment was designed.

The frequency of the test power source corresponding to the AC mains shall be between 49 Hz and 51 Hz.

5.6.2.2 Other power sources

For operation from other power sources or types of battery (primary or secondary), the normal test voltage shall be that declared by the equipment manufacturer.

5.7 Extreme test conditions

5.7.1 Extreme temperatures

For tests at extreme temperatures, measurements shall be made in accordance with clause 5.8, at a lower temperature of -20 °C and an upper temperature of +55 °C. This test shall be performed at the nominal supply voltage as defined in clause 5.6.2.

5.7.2 Extreme values of test power sources

5.7.2.1 Mains voltage

The extreme test voltages shall be between 207 V and 253 V. This test shall be performed at the normal temperature and humidity as defined in clause 5.6.1.

The frequency of the test voltage shall be between 49 Hz and 51 Hz.

5.7.2.2 Other power sources

For equipment using other power sources, or capable of being operated from a variety of power sources, the extreme test voltages shall be those agreed between the equipment manufacturer and the testing laboratory and shall be recorded in the test report.

5.8 Performance test

For the purposes of the present document, the term "performance test" shall be taken to mean the following measurements and limits:

- for the transmitter:
 - frequency error:
with the transmitter connected to a coaxial termination (see clause 5.1.1), the frequency error shall be as in clause 6.2;
 - carrier power:
with the transmitter connected to a coaxial termination (see clause 5.1.1), the transmitter shall be keyed without modulation and the output power shall be as defined in clause 6.3;
 - modulation:
with the transmitter connected to a coaxial termination (see clause 5.1.1), the transmitter shall be keyed. The modulation distortion shall be as in clause 6.4.3.
- for the receiver:
 - sensitivity:
with the AGC operative, a normal test signal (see clause 5.2.3) shall be applied to the receiver. The sensitivity shall be as defined in clause 7.1.

5.9 Environmental tests

5.9.1 General

Environmental tests shall follow checking the protection of the transmitter (see clause 4.5) which follows the first application of the Performance test (see clause 5.8).

5.9.2 Procedure for tests at extreme temperatures

Before tests at the upper extreme temperature ($55\text{ °C} \pm 3\text{ °C}$), the equipment shall be placed in the test chamber and left until thermal balance is attained. The equipment shall then be switched on for 30 minutes. The transmitter shall then be keyed for 1 minute in the transmit condition, after which the equipment shall meet the specified requirements. Transmitters shall be operated in the highest rated power transmit condition.

For tests at the lower extreme temperature ($-20\text{ °C} \pm 3\text{ °C}$), the equipment shall be left in the test chamber until thermal balance is attained, then switched to the standby or receive condition for 1 minute after which the equipment shall meet the specified requirements.

NOTE: It is assumed that equipment intended for off-set carrier operation will be installed in a building with facilities suitable to provide protection from temperature extremes, therefore extreme temperature tests need not be applied to such equipment.

5.9.3 Temperature tests

5.9.3.1 General

The chamber shall be able to maintain the required temperature value during the measurement.

5.9.3.2 High temperature

- Place the equipment in a chamber and heat to the required temperature value and allow to stabilize for 1 hour.
- Switch on the equipment.
- After 30 minutes carry out the performance test as detailed in clause 5.8.
- Switch off the equipment and allow the chamber to cool to room temperature over a 1 hour period.
- Allow time for the equipment to stabilize to normal room temperature and humidity before carrying out the next test.

5.9.3.3 Low temperature

- Place the equipment in a chamber and cool to the required temperature value for 2 hours.
- Switch on the equipment and maintain the chamber at the required operating temperature.
- After 10 minutes carry out the performance test as detailed in clause 5.8.
- Switch off the equipment and allow the chamber to rise to room temperature over a 1 hour period.
- Allow time for the equipment to stabilize to normal room temperature and for moisture to disperse before carrying out the next test.

6 Transmitter

6.1 General

All tests on the transmitter shall be carried out at the maximum rated output power (see clause 6.3.1) except where otherwise stated.

6.2 Frequency error

6.2.1 Definition

The frequency error is the difference between the measured carrier frequency and its nominal value.

6.2.2 Method of measurement

The carrier frequency shall be measured in the absence of modulation, with the transmitter connected to a coaxial termination (see clause 5.1.1). Measurements shall be made under normal test conditions (see clause 5.6) and under extreme test conditions (see clause 5.7) on 312,5 MHz.

6.2.3 Limits

The frequency error shall be within the requirements of table 1.

Table 1: Frequency error limits

| Frequency Error | Normal Temperature +15 °C to +35 °C | Extreme Temperature -20 °C to +55 °C |
|---------------------------|--|---|
| Fixed Base | ±5 ppm | ±10 ppm |
| 2-carrier offset system | ±5 ppm | N/A |
| 3/4-carrier offset system | ±1,2 ppm | N/A |

For 2-carrier, 3-carrier and 4-carrier offset systems the frequency shift values $\pm 7,5$ kHz, $\pm 5,0$ kHz, $\pm 2,5$ kHz and 0,0 kHz shall be used. The maximum allowed frequency deviation due to inaccuracy of the internal reference shall be less than ± 8 kHz.

6.3 Carrier power

6.3.1 Definitions

The carrier power is the ~~mean~~ power delivered to the coaxial termination during transmission in the absence of modulation.

6.3.2 Method of measurement

The transmitter shall be connected to a coaxial termination (see clause 5.1.1) and the output power delivered to this coaxial termination shall be measured at the output connector. The measurements shall be made under normal test conditions (see clause 5.6) for the highest and lowest transmitter power output level and at the highest transmitter power output level under extreme test conditions as applicable.

Measurements shall be made on the test channels (see clause 5.3).

6.3.3 ~~Tolerances~~ Limits

6.3.3.1 Normal test conditions

~~The carrier power measured under normal test conditions (see clause 5.6) with the output adjusted to maximum, shall not vary by more than $\pm 1,5$ dB from the rated maximum output power.~~ It shall be possible to limit the output power of the rated maximum output power.

6.3.3.2 Extreme test conditions

~~The carrier power measured under extreme test conditions (see clause 5.7) with the output adjusted to maximum rated power, shall not vary by more than $+1,5$ dB and -3 dB from the rated maximum output power.~~ equipment is taken into service. National usage restrictions are always met when the output adjusted to maximum rated power.

6.4 Amplitude modulation characteristic

6.4.1 Modulation depth

6.4.1.1 Definitions

Amplitude modulation depth

The amplitude modulation depth is the fractional ratio, expressed as a percentage, of the difference and the sum of the numerical values of the largest and smallest amplitudes encountered in one cycle of the modulating waveform.

Limiting threshold

The limiting threshold is defined as the minimum audio input level required to produce the manufacturers declared modulation depth for the equipment (85 % minimum at 1 kHz).

6.4.1.2 Method of measurement

The normal 1 kHz test signal shall be applied to the modulation input of the transmitter. The test signal level shall then be set at a level 3 dB above the limiting threshold.

The modulation depth shall be measured at the output of the transmitter connected to a coaxial termination (see clause 5.1.1), by means of a modulation analyser.

6.4.1.3 Limits

The amplitude modulation depth shall be at least 85 % under normal temperature conditions and at least 80 % for extreme temperature measurements.

6.4.2 Modulation compression

6.4.2.1 Definition

Modulation compression is the reduction of the modulation sensitivity at input signal levels above the limiting threshold determined in clause 6.4.1.

6.4.2.2 Method of measurement

The normal test signal of 1 kHz shall be applied to the modulation input of the transmitter tuned to 312,5 MHz.

The modulation depth shall be measured at the output of the transmitter connected to a coaxial termination (see clause 5.1.1), by means of a modulation analyser. Adjust the audio level applied to the modulation input to produce a modulation level of 30 %. Set the audio signal to produce modulation levels of 10 % and at the threshold that produces 85 %.

Confirm that when the level is varied between the values in table 2, the corresponding modulation depth changes are achieved within the stated tolerances.

With the audio input level set at the threshold that produces 85 % modulation, increase the level by 20 dB and record the maximum usable modulation depth.

6.4.2.3 Limits

The modulation shall be linear up to 85 % within ± 2 dB.

The maximum usable modulation depth shall not exceed 95 %.

Table 2: Modulation compression limits

| Level Increase | Modulation Change | Level Tolerance |
|----------------|-------------------|-----------------|
| 10 dB | 10 % to 30 % | ± 2 dB |
| 9 dB | 30 % to 85 % | +1 dB/-2 dB |

6.4.3 Amplitude modulation distortion

6.4.3.1 Definition

The amplitude modulation distortion is the ratio of the total rms_{RMS} voltage of all the harmonics of the modulated waveform to the total rms_{RMS} voltage.

6.4.3.2 Method of measurement

The normal test signal of 1 kHz set at a level 3 dB above the limiting threshold determined in clause 6.4.1 shall be applied to the modulation input of the transmitter.

The modulation distortion shall be measured at the output of the transmitter connected to a coaxial termination (see clause 5.1.1), by means of a distortion analyser.

6.4.3.3 Limits

The amplitude modulation distortion shall be less than 10 %.

6.4.4 Audio frequency response

6.4.4.1 Definition

The audio frequency response expresses the ability of the transmitter to operate without excessive degradation of its frequency response as a function of the modulation frequency.

6.4.4.2 Method of measurement

The audio frequency response shall be measured at 312,5 MHz.

The Normal test signal (see clause 5.2.3) shall be applied to the transmitter input and the level adjusted to give a modulation depth of 60 %.

The modulation frequency shall be varied between 300 Hz and 5 kHz, with the level of the audio input test signal kept constant.

The modulation depth shall be measured at the output of the transmitter connected to a coaxial termination (see clause 5.1.1), by means of a modulation analyser. The results shall be expressed in dB relative to 1 kHz in tabular and/or graphical format.

6.4.4.3 Limits

The modulation depth as measured over the modulating frequency range of 300 Hz to 3,4 kHz shall be less than +2 dB and -4 dB (referred to 1 kHz).

At 5 kHz the modulation depth shall be at least -25 dB referred to 1 kHz.

6.5 Adjacent channel power

6.5.1 Definition

The adjacent channel power is that part of the total power output of a transmitter under defined conditions of modulation, which falls within a specified passband centred on the nominal frequency of either of the adjacent channels. This power is the sum of the mean power produced by the modulation, hum and noise of the transmitter.

6.5.2 Measurement

The adjacent channel power shall be measured with a power measuring receiver, or an equivalent analyser here referred to as the "measurement receiver", conforming to annex B:

- a) the transmitter shall be operated at the maximum carrier power determined in clause 6.3 under normal test conditions. The output of the transmitter shall be linked to the input of the "measurement receiver" by a connecting device such that the impedance presented to the transmitter is 50 Ω and the level at the "measurement receiver" input is appropriate;
- b) the transmitter shall be modulated with a signal at 1 kHz at a level required to produce a modulation depth of 85 %;
- c) with the transmitter modulated, the tuning of the "measurement receiver" shall be adjusted so that a maximum response is obtained. This is the 0 dB response point. The "measurement receiver" attenuator setting and the reading of the meter shall be recorded;
- d) the tuning of the "measurement receiver" shall be adjusted away from the carrier so that the "receiver" -6 dB response nearest to the transmitter carrier frequency is located at a displacement from the nominal carrier frequency of 17 kHz;
- e) the "measurement receiver" variable attenuator shall be adjusted to obtain the same meter reading as in step c) or a known relation to it;

- f) the ratio of adjacent channel power to carrier power is the difference between the attenuator settings in steps c) and e), corrected for any differences in the reading of the meter;
- g) the measurement shall be repeated with the "measurement receiver" tuned to the other side of the carrier.

6.5.3 Limits

The adjacent channel power shall not exceed -60 dBc.

6.6 Broadband noise

6.6.1 Definition

The broadband noise test determines the phase noise generated by the transmitter, (when keyed), between the adjacent channel and within the spurious emission exclusion band. It is necessary to minimize the effects of this noise in order to prevent desensitization of receivers operating on frequencies close to the transmitter.

6.6.2 Method of measurement

Method 1

- a) The transmitter shall be operated at the maximum unmodulated carrier power determined in clause 6.3 under normal test conditions. The output of the transmitter shall be connected to a Signal Source Analyser utilizing a cross-correlation method via a coax termination (see clause 5.1.1) and the level at the Signal Source Analyser input is appropriate.
- b) Measurements shall be made on the centre test channel (see clause 5.3).
- c) Measure the phase noise at 1 % offset (3,125 MHz), taking the maximum values in a $\pm 12,5$ kHz bandwidth.

Method 2

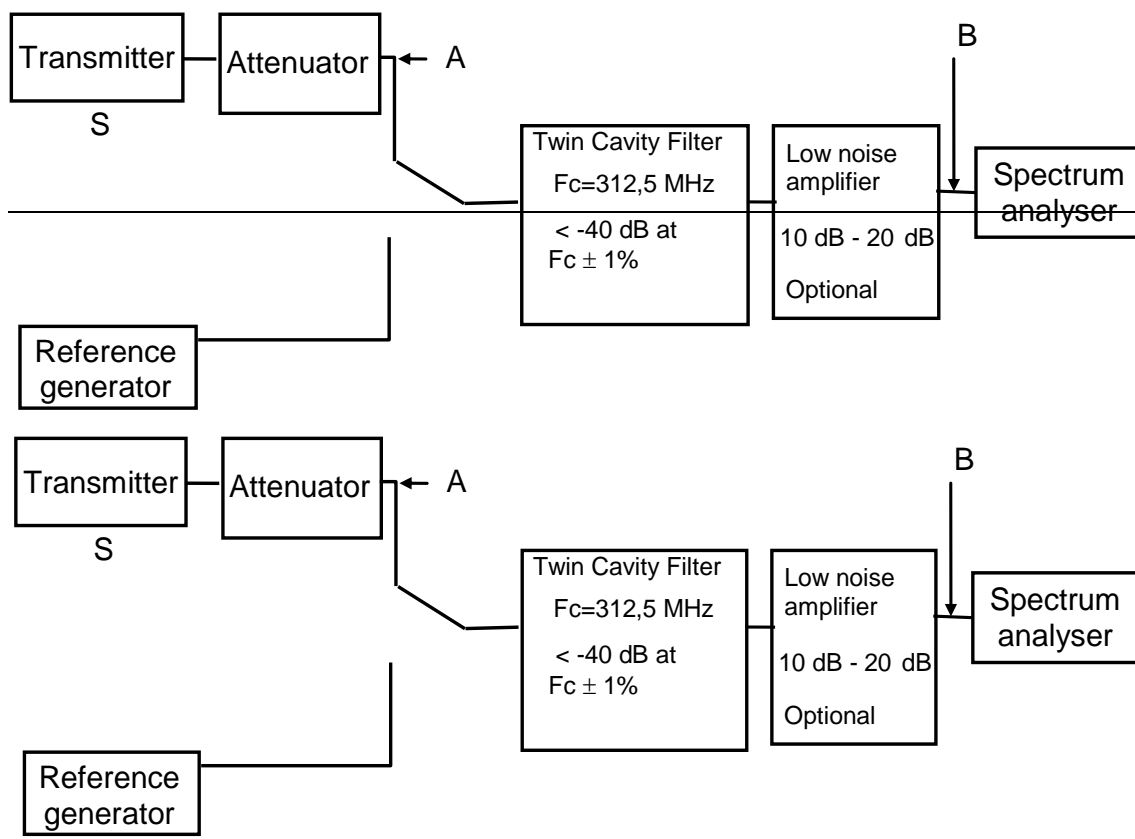

Figure 1: Broadband noise measurement

The following method of measurement shall be used when a Signal Source Analyser utilizing a cross-correlation method is not available:

- a) Measurements shall be made at the centre test frequency (see clause 5.3).
- b) Connect equipment as shown in figure 1.
- c) Initially connect the spectrum analyser to the attenuator output (point A). Set the transmitter to produce an unmodulated carrier at 312,5 MHz. Using a 50 kHz span and a 1 kHz bandwidth, note the output reference power (Pr).
- d) Reconnect the analyser to the filter output (point B) and connect the attenuator output to the cavity filter tuned to 312,5 MHz.
- e) Adjust the transmitter frequency to 315,625 MHz. Key the transmitter and apply modulation at 1 kHz at a level to give 85 % modulation depth. Monitor the noise level on the spectrum analyser. Use the analysers averaging function to find the mean level at 312,5 MHz in a 25 kHz bandwidth. Note this level as (Pm).
- f) De-key the transmitter and apply an unmodulated signal from the reference generator at 312,5 MHz. Increase the RF level until it is the same amplitude as the noise level noted above (Pm). Record this level as Pmref.
- g) The wide band noise at 1 % offset is then determined from the following formulae:
 - $WB\ noise = Pmref + Pr + BW\ correction\ (dBc/Hz).$

Where BW correction for 1 kHz = 30 dB. (For example if Pmref was -105 dBm and Pr = +10 dBm then the WB noise is $105 + 10 + 30 = 145\ dBc/Hz$).
- h) Adjust the transmitter frequency to 309,375 MHz and repeat the test.

6.6.3 Limit

The broadband noise limit shall be: < -150 dBc/Hz at 1 % offset.

6.7 Conducted spurious emissions (TX)

6.7.1 Definition

Conducted spurious emissions are RF emissions appearing at the RF output port on a frequency or frequencies which are outside the necessary bandwidth and the level of which may be reduced without affecting the corresponding transmission of information. Conducted spurious emissions include harmonic emissions, parasitic emissions, intermodulation products and frequency conversion products, but exclude out of band emissions.

6.7.2 Method of measurement

- a) Conducted spurious emissions shall be measured with the unmodulated transmitter connected to the coaxial termination (see clause 5.1.1) and operating on the centre test frequency (see clause 5.3).
- b) The measurements shall be made over a range from 9 kHz to 4 GHz, excluding the channel on which the transmitter is operating and separated from the centre frequency of the emission by $\pm 1\ MHz$.
- c) The measurements for each spurious emission shall be made using a tuned radio measuring instrument or a spectrum analyser.
- d) The measurements shall be repeated with the transmitter in standby mode.

6.7.3 Limits

The limits defined in table 3 shall be applied.

Table 3: Conducted spurious emissions limits

| Environmental phenomena | Frequency range | Units | Test limits, Tx Standby | Test limits Tx active mode | Reference bandwidth (B) |
|---------------------------------|---------------------|-------|-------------------------|---|-------------------------|
| Spurious conducted RF Emissions | 9 kHz to 150 kHz | dBm | -57 (2 nW) | -46 dBm | B = 1 kHz |
| Spurious conducted RF Emissions | > 150 kHz to 30 MHz | dBm | -57 (2 nW) | -46 dBm | B = 10 kHz |
| Spurious conducted RF Emissions | > 30 MHz to 1 GHz | dBm | -57 (2 nW) | -65 dBc for second harmonic, -75 dBc for all other harmonics -43 dBm for non-harmonic spurious | B = 10 kHz (see note) |
| Spurious conducted RF Emissions | > 1 GHz to 4 GHz | dBm | -47 (20 nW) | -75 dBc for harmonics -40 dBm for non-harmonic spurious | B = 10 kHz |

NOTE: An exclusion band of ± 1 MHz about the carrier shall be used in active transmit mode.

6.8 Intermodulation attenuation

6.8.1 Definition

Intermodulation attenuation is the capability of a transmitter to avoid the generation of signals in the non-linear elements caused by the presence of the carrier and an interfering signal entering the transmitter via the antenna.

It is specified as the ratio, in dB, of the power level of the third order intermodulation product to the carrier power level.

6.8.2 Method of measurement

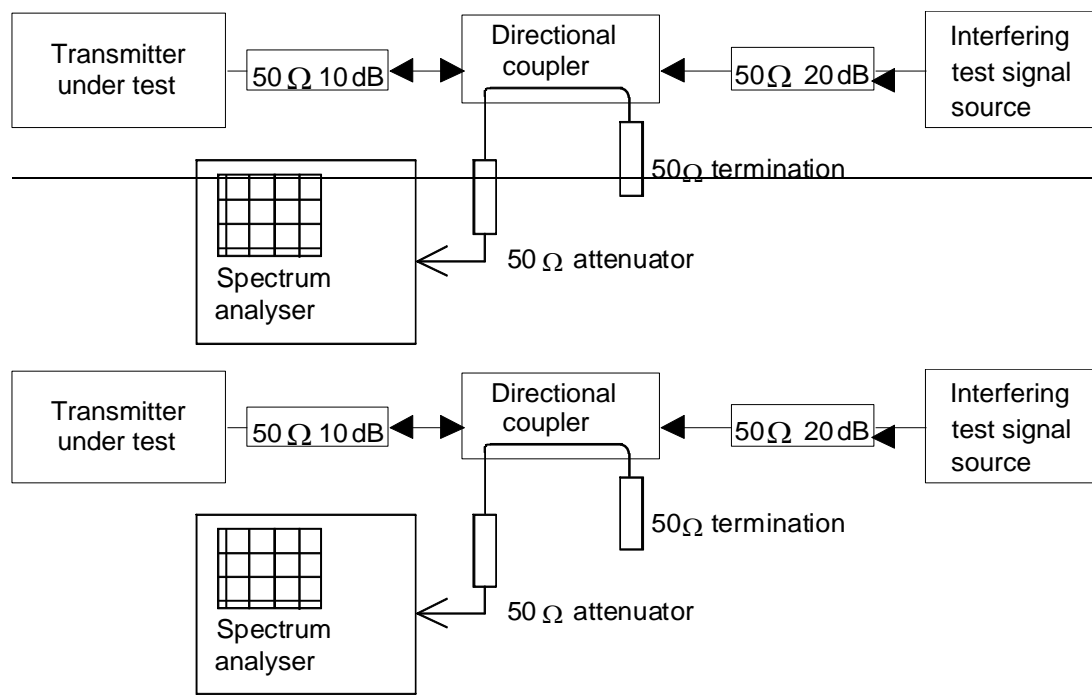

Figure 2: Measurement arrangement

The following method of measurement shall be used:

- Conducted spurious emissions shall be measured while operating on the test channels (see clause 5.3).
- The measurement arrangement shown in figure 2 shall be used.

- c) The transmitter shall be connected to a 50 Ω , 10 dB power attenuator and via a directional coupler to a spectrum analyser. An additional attenuator may be required between the directional coupler and the spectrum analyser to avoid overloading the spectrum analyser.
- d) In order to reduce the influence of mismatch errors it is important that the 10 dB power attenuator is coupled to the transmitter under test with the shortest possible connection.
- e) The interfering test signal source is connected to the other end of the directional coupler via a 50 Ω , 20 dB power attenuator.
- f) The interfering signal source may be either a transmitter providing the same power output as the transmitter under test and be of a similar type or a signal generator and a linear power amplifier capable of delivering the same output power as the transmitter under test.
- g) The directional coupler shall have an insertion loss of less than 1 dB, a sufficient bandwidth and a directivity of more than 20 dB.
- h) The transmitter under test and the test signal source shall be physically separated in such a way that the measurement is not influenced by direct radiation.
- i) The transmitter under test shall be unmodulated and the spectrum analyser adjusted to give a maximum indication with a frequency scan width of 500 kHz.
- j) The interfering test signal source shall be unmodulated and the frequency shall be within 150 kHz to 200 kHz above the frequency of the transmitter under test.
- k) The frequency shall be chosen in such a way that the intermodulation components to be measured do not coincide with other spurious components.
- l) The power output of the interfering test signal source shall be adjusted to the carrier power level of the transmitter under test by the use of a power meter.
- m) The intermodulation component shall be measured by direct observation on the spectrum analyser and the ratio of the largest third order intermodulation component to the carrier recorded.
- n) This measurement shall be repeated with the interfering test signal source at a frequency within 150 kHz to 200 kHz below the frequency of the transmitter under test.

6.8.3 Limits

The intermodulation protection ratio shall be at least 40 dB.

6.9 RF power attack time and release time

6.9.1 Definitions

The transmitter power attack time (t_a) is the time which elapses between:

- $t_{on L}$: defined by the condition when the transmitter output power, measured at the antenna terminal, exceeds -20 dBc;
- $t_{on H}$: defined by the condition when the transmitter output power has reached -1,5 dBc.

The transmitter release time (t_r) is the time which elapses between:

- $t_{off H}$: defined by the condition when the transmitter output power falls below -1,5 dBc;
- $t_{off L}$: defined by the condition when the transmitter output power has reached -20 dBc.

The measured value of t_a and t_r are respectively t_{am} (transmitter attack measurement) and t_{rm} (transmitter release measurement), the limits are respectively t_{al} and t_{rl} .

6.9.2 Method of measurement

6.9.2.1 Attack time

The following method of measurement shall be used:

- a) the transmitter is connected to a RF detector via a matched test load. The attenuation of the test load shall be chosen in such a way that the input of the RF detector is protected against overload and the detector operates as soon as the transmitter is keyed:
 - a dual trace storage oscilloscope (or a transient recorder) records the amplitude transient from the detector on a logarithmic scale;
 - a trigger device may be required to ensure that the start of the sweep of the oscilloscope time-based occurs the instant at which the "transmitter $t_{on L}$ " function is initiated;
 - a spectrum analyser can also be used;
- b) the traces of the oscilloscope shall be calibrated in power (y-axis) and in time (x-axis), using the signal generator;
- c) the transmitter attack time shall be measured by direct reading on the oscilloscope while the transmitter is unmodulated and operating on the centre test frequency (see clause 5.3).

6.9.2.2 Release time

The following method of measurement shall be used:

- a) the transmitter is connected to a RF detector via a matched test load. The attenuation of the test load shall be chosen in such a way that the input of the RF detector is protected against overload and the detector operates as soon as the transmitter is keyed:
 - a dual trace storage oscilloscope (or a transient recorder) records the amplitude transient from the detector on a logarithmic scale;
 - a trigger device may be required to ensure that the start of the sweep of the oscilloscope time-based occurs the instant at which the "transmitter $t_{off H}$ " function is de-activated;
 - a spectrum analyser can also be used;
- b) the traces of the oscilloscope shall be calibrated in power (y-axis) and in time (x-axis), using the signal generator;
- c) the transmitter release time shall be measured by direct reading on the oscilloscope while the transmitter is unmodulated and operating on the centre test frequency (see clause 5.3).

6.9.3 Limits

- t_{a1} shall be < 20 ms;
- t_{r1} shall be < 10 ms.
- The keying time (the period from the initial keying signal to the point when the transmitter produces 90 % of the transmit power) shall be < 50 ms.

6.10 Keying Transient frequency behaviour of the transmitter

6.10.1 Definition

The transient frequency behaviour of the transmitter due to the wide-band spectral response caused by switching of the keyline.

6.10.2 Method of measurement

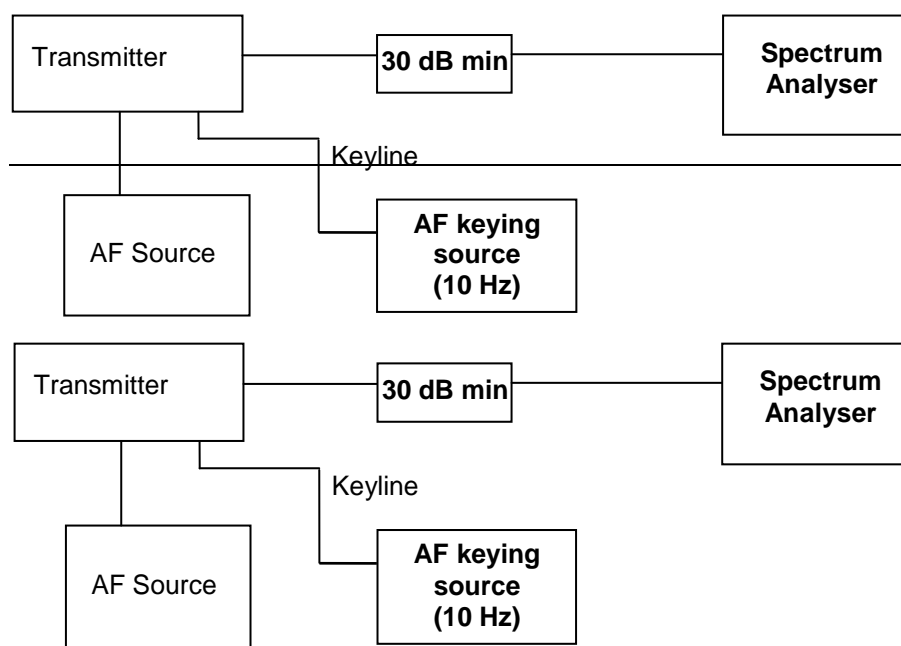

Figure 3: Measurement arrangement

The following method of measurement shall be used:

- a) The transmitter shall be connected via a 50 Ω power attenuator, capable of reducing the RF power to a safe level for the spectrum analyser.
- b) The transmitter shall be set to 225 MHz and be modulated by a 1 kHz tone to produce a modulation depth of 85 %.
- c) The analyser shall be adjusted to the nominal frequency of the transmitter and the span adjusted to 100 kHz with a 1 kHz bandwidth.
- d) The transmitter shall be keyed and the spectrum analyser settings adjusted to display a centre frequency response at the reference level (using maximum hold function), with at least 60 dB dynamic range.
- e) The transmitter Keyline shall then be controlled by a suitable switching signal which shall allow the transmitter to be keyed at a rate of at least 5 Hz.
- f) The analyser shall be set to maximum hold and the keyline switched at the above rate for at least 2 minutes.
- g) The analyser display shall be recorded.
- h) Repeat for all test channels (see clause 5.3).

6.10.3 Limits

The transients shall be at least 30 dB below the reference level at frequencies separated from the carrier by more than 10 kHz.

6.11 Cabinet Radiation (TX)

The transmitter shall meet the cabinet radiation requirements specified in clause 7.5 of ETSI EN 300 113-1 [1].

7 Receiver

7.1 Sensitivity

7.1.1 Definition

The sensitivity of the receiver is the level of the signal at the nominal frequency of the receiver which, when applied to the receiver input with normal test modulation (see clause 5.2.3), produces:

- in all cases, an audio frequency output power not less than 50 % of the rated output power (see clause 5.2.5); and
- a SINAD ratio of 12 dB, measured at the receiver output using a psophometric telephone filtering network as described in Recommendation ITU-T O.41 [2].

7.1.2 Method of measurement

- a) A normal test signal (see clause 5.2.3) at a carrier frequency equal to the nominal frequency of the receiver shall be applied to the receiver input. An audio frequency load and a measuring instrument for measuring the SINAD ratio (through a psophometric network) shall be connected to the receiver output terminals.
- b) The level of the test signal shall be adjusted until a SINAD ratio of 12 dB is obtained, using the psophometric network and with the receiver's audio power control adjusted to produce 50 % of the rated output power. Under these conditions, the level of the test signal at the input is the value of the maximum sensitivity.
- c) The measurements shall be made under normal test conditions (see clause 5.6) and under extreme test conditions (see clause 5.7), as applicable.
- d) A receiver output power variation of ± 3 dB relative to 50 % of the rated output power may be allowed for sensitivity measurements under extreme test conditions. The measurements shall be performed on all test channels (see clause 5.3).

7.1.3 Limits

The maximum sensitivity shall not exceed -101 dBm under normal test conditions and -95 dBm under extreme test conditions as applicable.

7.2 Effective acceptance bandwidth

7.2.1 Definition

The effective acceptance bandwidth is the frequency range over which an applied signal shall not be rejected by the receiver. This bandwidth allows the reception of offset carriers.

7.2.2 Method of measurement

A test signal (see clause 5.2.3) at the centre test frequency (see clause 5.3) at a RF level necessary to achieve a 12 dB SINAD via a psophometric filter, shall be applied to the receiver input under normal test conditions (see clause 5.6). The RF signal shall then be increased by 6 dB.

The test signal frequency shall be varied $\pm 8,5$ kHz from the nominal carrier frequency of the receiver with the test signal amplitude being kept constant and equal to the value specified above.

7.2.3 Limits

The SINAD ratio shall be > 12 dB. The test signal frequency shall be at least $\pm 8,5$ kHz from the nominal carrier frequency.

NOTE: For receivers intended for use with 3 and 4 offset channels a 6 dB point of ± 11 kHz is recommended.

7.3 Adjacent channel rejection

7.3.1 Definition

The adjacent channel rejection is a measure of the capability of the receiver to receive a wanted modulated signal without exceeding a given degradation due to the presence of an unwanted modulated signal which differs in frequency from the wanted signal by 25 kHz as appropriate.

7.3.2 Method of measurement

- a) Measurements shall be made on the test channels (see clause 5.3).
- b) The two input signals from signal generators G1 and G2 shall be applied to the receiver input via a combining network. An audio analyser shall be connected to the receiver output terminals via a psophometric filter.
- c) With the output of G2 switched off, the wanted test signal from G1 at the receive frequency, shall be set to produce a modulation depth of 60 % at 1 kHz.
- d) Adjust the level of G1 to achieve a SINAD of 12 dB at the receiver output terminals.
 - This shall be recorded as Level 1.
- e) Repeat the measurement but this time switch off G1 and adjust G2, modulated 60 % at 1 kHz, to achieve a SINAD of 12 dB at the receiver output terminals.
 - This shall be recorded as Level 2.
- f) Switch on generator G1. Set G2 to a frequency of one channel separation above the nominal frequency of the receiver and apply modulation at 400 Hz with 60 % modulation depth.
- g) The amplitude of the unwanted signal shall be adjusted until the SINAD ratio at the output of the receiver is reduced to 6 dB.
 - Record this level as Level 3.
- h) The upper adjacent channel rejection is the difference between Level 3 and Level 2.
- i) The measurement shall be repeated with the unwanted signal (G2) on the channel below that of the wanted signal.
- j) For the upper and lower adjacent channel measurements the minimum difference shall be recorded as the adjacent channel rejection.
- k) The measurement shall be repeated on the test channels (clause 5.3).

7.3.3 Limits

The adjacent channel rejection shall be greater than 60 dB.

7.4 Spurious response rejection

7.4.1 Definition

The spurious response rejection is a measure of the capability of the receiver to discriminate between the wanted modulated signal at the nominal frequency and an unwanted signal at any other frequency at which a response is obtained.

7.4.2 Introduction to the method of measurement

The method of measurement hereafter described is not intended to capture all spurious responses but selects those that have a high probability of being present. This method provides a high degree of confidence that the equipment also meets the requirements at frequencies not being measured directly.

To determine the frequencies at which spurious responses can occur the following calculations shall be made:

a) ~~calculation~~ Calculation of the "limited frequency range":

- the limited frequency range is defined as the frequency of the local oscillator signal (f_{LO}) applied to the first mixer of the receiver plus or minus the sum of the intermediate frequencies ($if_1 \dots if_n$) and a half of the maximum frequency range (fr_m) of the receiver.

$$\text{Hence the limited frequency range} = \underline{f_{LO} \pm (if_1 + if_2 + \dots + if_n + fr_m/2)}$$

For equipment employing a first intermediate frequency of > 100 MHz the upper limit of the limited frequency range shall be 400 MHz.

b) ~~calculation~~ Calculation of frequencies outside the limited frequency range:

- the frequencies outside the limited frequency range determined in a) are equal to the harmonics of the frequency of the local oscillator signal (f_{LO}) applied to the first mixer of the receiver plus or minus the first intermediate frequency (f_{i1}) of the receiver;
- hence the frequencies of these spurious responses are $nf_{LO} \pm f_{i1}$, where n is an integer greater than or equal to 2;
- the measurement of the first image response of the receiver shall initially be made to verify the calculation of spurious response frequencies.

For calculations a) and b), the manufacturer shall state the frequency of the receiver, the frequency of the local oscillator signal (f_{LO}) applied to the first mixer of the receiver, the intermediate frequencies (f_{i1} , f_{i2} , etc.), and the maximum frequency range (fr_m) of the receiver.

7.4.3 Method of search of the limited frequency range

- a) The normal test signal shall be applied (see clause 5.2.3), while operating on the centre test frequency (see clause 5.3).
- b) The test signal shall be adjusted to a level corresponding to a SINAD ratio of 12 dB via a psophometric filter and recorded as the reference level.
- c) The input level of the test signal shall then be adjusted to 80 dB above the reference level.
- d) The frequency shall be varied continuously over the limited frequency range determined in clause 7.4.2 a) and over the frequencies outside the frequency range in accordance with the calculations in clause 7.4.2 b).
- e) The frequency of any spurious responses detected during the search shall be recorded for the use in the measurement described in the following clause.

7.4.4 Method of measurement

- a) The test signal from a signal generator shall be applied to the receiver input. An ~~rms~~ RMS voltmeter shall be connected to the receiver output via a psophometric filter.
- b) The test signal shall be a normal test signal (see clause 5.2.3) at the nominal frequency of the receiver.
- c) The RF signal level shall be adjusted to produce a SINAD ratio of 12 dB, and the RF level recorded as the reference level.
- d) The signal generator shall then be tuned to a spurious response frequency detected according to clause 7.4.3 and modulated with normal test modulation.
- e) The level of the RF signal is increased until the receiver output signal produces an SINAD ratio of 12 dB.
- f) This RF signal level shall be recorded as the unwanted signal level.
- g) The spurious response rejection ratio is the ratio in dB of the unwanted signal level to the reference level.
- h) This measurement shall be made for each frequency detected according to clause 7.4.3.

7.4.5 Limit

At any frequency separated from the nominal frequency of the receiver by more than two channels, the spurious response rejection ratio shall be not less than 70 dB.

7.5 Intermodulation response rejection

7.5.1 Definition

The intermodulation response rejection is the capability of a receiver to receive a wanted modulated signal at the nominal frequency, without exceeding a given degradation due to the presence of two or more unwanted signals with a specific frequency relationship to the wanted signal frequency.

7.5.2 Method of measurement

The following method of measurement shall be used:

- a) Intermodulation response rejection shall be made on the test channels (clause 5.3).
- b) The wanted signal from signal generator A, at the nominal frequency and producing a normal test signal (see clause 5.2.3) shall be applied to the input of the receiver via a combining network.
- c) The unwanted signal from signal generator B, at the frequency 500 kHz above the nominal frequency of the receiver and without modulation shall be applied to the receiver via the second input of the combining network.
- d) An ~~rms~~RMS voltmeter shall be connected to the receiver output via a psophometric filter.
- e) With the unwanted signal switched off, the level of the wanted signal shall be set to -53 dBm and the receiver volume control adjusted to obtain approximately 50 % of the rated audio output power.
- f) The level of the wanted signal shall be reduced until a 12 dB SINAD ratio is obtained.
- g) The level of the wanted signal under these conditions shall be recorded (x).
- h) The frequency of the wanted signal shall then be changed to a frequency of 1 MHz above the nominal frequency of the receiver. This signal now constitutes the second unwanted signal.
- i) The level of the two unwanted signals shall be kept equal and increased in level until a 12 dB SINAD ratio is again obtained. If necessary the frequency of either signal shall be varied slightly to obtain the maximum value of this ratio, their levels being re-adjusted to restore the 12 dB SINAD ratio.
- j) The level of the two signals under these conditions shall be recorded (y).
- k) The ratio, in dB, of the levels of the unwanted signals (y) to that recorded for the wanted signal (x) is the intermodulation response rejection ratio.
- l) These measurements shall be made on both sides of the nominal frequency.

7.5.3 Limit

The intermodulation response rejection ratio shall be > 75 dB.

7.6 Blocking or desensitization

7.6.1 Definition

Blocking is a measure of the capability of the receiver to receive a wanted modulated signal without exceeding a given degradation due to the presence of an unwanted input signal at any frequencies other than those of the spurious responses or the adjacent channels.

7.6.2 Method of measurement

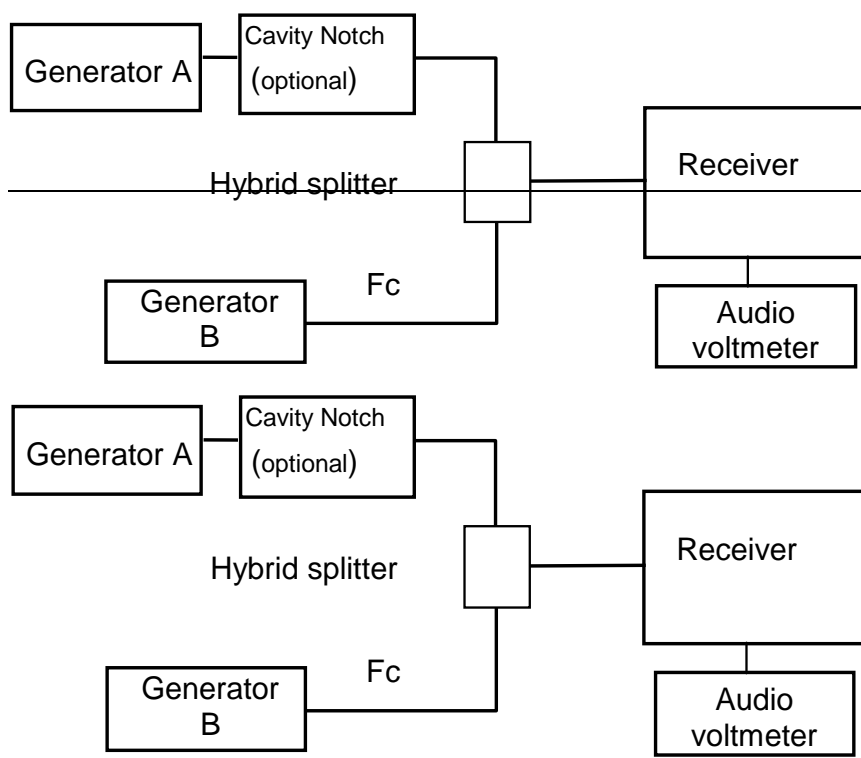

Figure 4: Measurement arrangement

The following method of measurement shall be used:

NOTE: For high performance base stations it may not be possible to measure the true blocking without the use of a cavity notch in the interfering path.

- a) Two input signals shall be applied to the receiver via a combining network. A cavity notch filter at the receiver frequency may be used to improve the noise performance of the test equipment. An ~~rms~~**RMS** voltmeter shall be connected to the receiver output terminals via a psophometric filter.
- b) The wanted normal test signal (see clause 5.2.3), at the centre test channel (clause 5.3), and at the sensitivity level (see clause 7.1) of the receiver shall be applied to the receiver input connector via one of the inputs of the combining network (Generator B).
- c) Where available, the receiver volume control shall be adjusted to give at least 50 % of the rated output power (see clause 5.2.5).
- d) The unwanted signal shall be unmodulated and the frequency shall be +3,125 MHz and -3,125 MHz relative to the nominal frequency of the receiver. The input level of the unwanted signal shall be adjusted until:
 - 1) the audio output level of the wanted signal is reduced by 3 dB; or
 - 2) the SINAD ratio, psophometrically weighted, at the receiver output is reduced to 6 dB.
- e) The measure of the blocking or desensitization is the ratio in dB of the level of the unwanted test signal to the level of the wanted test signal at the receiver input for which the specified reduction in audio output level or SINAD ratio occurs.
- f) The measurements shall be made while operating on the centre test channel (clause 5.3).

7.6.3 Limit

The blocking ratio, for any frequency within the specified ranges, shall not be less than 90 dB at 1 % offset.

7.7 Conducted spurious emissions

7.7.1 Definition

Conducted spurious emissions from the receiver are signals at any frequency, emitted from the antenna port. The level of spurious emissions shall be measured by their power level at the antenna connector.

7.7.2 Method of measuring the power level

Spurious emissions shall be measured as the power level of any discrete signal at the RF input terminal of the receiver. Connect the receiver input terminal to a spectrum analyser or selective voltmeter having an input impedance of 50 Ω and switch the receiver on.

If the detecting device is not calibrated in terms of power input, the level of any detected components shall be determined by a substitution method using a signal generator.

The measurements shall extend over the frequency range of 9 kHz to 4 GHz. The measurement shall be made while operating on the test channels (clause 5.3).

7.7.3 Limits

The power of any conducted spurious emission shall not exceed the values given in table 4.

Table 4: Conducted spurious emissions limits

| Environmental phenomena | Frequency range | Units | Test limits Rx | Reference bandwidth |
|---|---------------------|-------|--------------------------|---------------------|
| Spurious conducted RF Emissions | 9 kHz to 150 kHz | dBm | -57 (2 nW) | B = 1 kHz |
| Spurious conducted RF Emissions | > 150 kHz to 30 MHz | dBm | -57 (2 nW) | B = 10 kHz |
| Spurious conducted RF Emissions | > 30 MHz to 1 GHz | dBm | -57 (2 nW) (see note) | B = 100 kHz |
| Spurious conducted RF Emissions | > 1 GHz to 4 GHz | dBm | -47 (20 nW) | B = 100 kHz |
| NOTE: Spurious limit -81 dBm, with a reference bandwidth of 10 kHz, for ground base station equipment in the band 225 MHz to 399,975 MHz. | | | | |

7.8 Cross modulation rejection

7.8.1 Definition

Cross modulation is the transposition of the AM component from a strong unwanted signal to the wanted signal.

Cross modulation rejection is the level difference between an unwanted signal and the maximum sensitivity level (as defined in clause 7.1) at the point where the audio component due to cross modulation tone reduces the SINAD ratio of the wanted signal to 20 dB.

7.8.2 Method of measurement

NOTE 1: For high performance base stations it may not be possible to measure the true cross modulation without the use of a cavity notch in the interfering path (see clause 7.9.2 for test arrangement).

- a) The two input signals shall be connected to the receiver via combining network. A cavity notch filter at the receiver frequency may be used to improve the noise performance of the test equipment. An ~~rms~~RMS voltmeter shall be connected to the receiver output terminals via a psophometric filter.
- b) The wanted signal, a normal test signal (see clause 5.2.3) at the nominal frequency of the receiver, shall be applied to the receiver input connector via one of the inputs of the combining network. The level of the signal will be set to produce a 30 dB SINAD ratio measured at the receiver output using a psophometric telephone filtering network as described in Recommendation ITU-T O.41 [2].
- c) The unwanted signal at a frequency offset of 1 MHz with respect to the nominal frequency of the receiver and amplitude modulated with 400 Hz at a depth of modulation of 30 % shall be applied to the second input of the combining network.

- d) The RF output level of the unwanted signal shall be increased until the 400 Hz tone reduces the SINAD ratio of the wanted signal to 20 dB.

NOTE 2: The interfering source should be a low noise generator, otherwise additional filtering of the RF signal may be required to prevent wideband noise masking the measurement.

- e) The ratio between this RF level of the unwanted signal and the maximum sensitivity (as defined in clause 7.1) is the cross modulation rejection.
- f) The measurement shall be repeated for an interfering signal at -1 MHz with respect to the nominal frequency of the receiver.
- g) This test shall be performed at the centre test channel (clause 5.3).

7.8.3 Limits

The cross modulation rejection ratio shall be at least 80 dB.

7.9 Receiver dynamic range

7.9.1 Definition

The receiver dynamic range expresses the capability of the receiver to limit the resulting audio output as a function of varying input signal levels.

7.9.2 Method of measurement

A normal test signal (see clause 5.2.3) on the centre test channel (clause 5.3) with a level equal to the limit of the maximum sensitivity (see clause 7.1) shall be applied to the receiver under normal test conditions (see clause 5.6). The resulting audio output shall be measured by an AF power meter connected to the receiver and the value noted. The RF input level shall then be increased by 100 dB and the AF output level shall again be noted.

7.9.3 Limit

The RF automatic gain control shall process an input level change of 100 dB with respect to the limit of the maximum sensitivity level to less than 6 dB resulting audio output power changes.

7.10 Cabinet Radiation (RX)

The receiver shall meet the cabinet radiation requirements specified in clause 8.10 of ETSI EN 300 113-1 [1].

8 Testing for compliance with technical requirements

8.1 Environmental conditions for testing

These shall be as described in clause 5.

8.2 Interpretation of the measurement results

The interpretation of the results recorded in a test report for the measurements described in the present document shall be as follows:

- the measured value related to the corresponding limit will be used to decide whether an equipment meets the requirements of the present document;
- the value of the measurement uncertainty for the measurement of each parameter shall be included in the test report;
- the recorded value of the measurement uncertainty shall be, for each measurement, equal to or less than the figures in table 5 and table 6.

For the test methods, according to the present document, the measurement uncertainty figures shall be calculated and shall correspond to an expansion factor (coverage factor) $k = 1,96$ or $k = 2$ (which provide confidence levels of respectively 95 % and 95,45 % in the case where the distributions characterizing the actual measurement uncertainties are normal (Gaussian)). Principles for the calculation of measurement uncertainty are contained in ETSI TR 100 028 [i.2], in particular in annex D of the ETSI TR 100 028-2 [i.4].

Table 5 and table 6 are based on such expansion factors.

Table 5: Maximum measurement uncertainty (TX)

| Measurement uncertainties | Maximum values |
|--|---------------------------------|
| Frequency error | $\pm 1 \times 10^{-9}$ |
| Carrier power (normal and extreme test conditions) | $\pm 0,75$ dB |
| Modulation depth | ± 3 % |
| Modulation compression | ± 3 % |
| Amplitude modulation distortion | ± 3 % |
| Audio frequency response | ± 2 dB |
| Adjacent channel power | $\pm 2,5$ dB |
| Broadband noise | ± 3 dB |
| Conducted spurious emissions: | |
| - below 1 GHz | ± 3 dB |
| - between 1 GHz and 4 GHz | ± 6 dB |
| Radiated spurious emission valid up to 4 GHz | ± 6 dB |
| Transient frequency behaviour | ± 250 Hz |
| Intermodulation | ± 3 dB |
| RF power attack and release times | ± 20 % of the limits values |
| Keying transient frequency behaviour | ± 3 dB |

Table 6: Maximum measurement uncertainty (RX)

| Measurement uncertainties | Maximum values |
|--|----------------|
| Receiver sensitivity | ± 3 dB |
| Effective acceptance bandwidth | ± 3 dB |
| Adjacent channel rejection | ± 4 dB |
| Spurious response rejection | ± 4 dB |
| Intermodulation response rejection | ± 3 dB |
| Blocking and desensitization | ± 4 dB |
| Conducted spurious emissions: | |
| - below 1 GHz | ± 3 dB |
| - between 1 GHz and 4 GHz | ± 6 dB |
| Radiated spurious emission valid up to 4 GHz | ± 6 dB |
| Cross modulation rejection | ± 4 dB |
| Receiver dynamic range | ± 2 dB |

Annex A (informative): Relationship between the present document and the essential requirements of Directive 2014/53/EU

The present document has been prepared under the Commission's standardisation request C(2015) 5376 final [i.7i.7] to provide one voluntary means of conforming to the essential requirements of Directive 2014/53/EU on the harmonisation of the laws of the Member States relating to the making available on the market of radio equipment and repealing Directive 1999/5/EC [i.1].

Once the present document is cited in the Official Journal of the European Union under that Directive, compliance with the normative clauses of the present document given in table A.1 confers, within the limits of the scope of the present document, a presumption of conformity with the corresponding essential requirements of that Directive and associated EFTA regulations.

Table A.1: Relationship between the present document and the essential requirements of Directive 2014/53/EU

| Harmonised Standard ETSI EN 302 617 | | | | | |
|-------------------------------------|---|-------------------------------------|---|----------------------------|--|
| Requirement | | | | Requirement Conditionality | |
| No | Description | Essential requirements of Directive | Reference: Clause No(s) of the present document | U/C | Condition |
| 1 | Frequency control | 3.2 | 4.1 | U | |
| 2 | Class of emission and modulation characteristics | 3.2 | 4.3 | U | |
| 3 | Frequency error | 3.2 | 6.2 | C | This requirement applies to transmitter equipment. |
| 4 | Carrier power | 3.2 | 6.3 | C | This requirement applies to transmitter equipment. |
| 5 | Amplitude modulation characteristic | 3.2 | 6.4 | C | This requirement applies to transmitter equipment. |
| 6 | Adjacent channel power | 3.2 | 6.5 | C | This requirement applies to transmitter equipment. |
| 7 | Broadband noise | 3.2 | 6.6 | C | This requirement applies to transmitter equipment. |
| 8 | Conducted Spurious emissions (TX) | 3.2 | 6.7 | C | This requirement applies to transmitter equipment. |
| 9 | Intermodulation attenuation | 3.2 | 6.8 | C | This requirement applies to transmitter equipment. |
| 10 | RF power attack time and release time | 3.2 | 6.9 | C | This requirement applies to transmitter equipment. |
| 11 | Keying transient frequency behaviour of the transmitter | 3.2 | 6.10 | C | This requirement applies to transmitter equipment. |
| 12 | Cabinet Radiation (TX) | 3.2 | 6.11 | C | This requirement applies to transmitter equipment. |
| 13 | Sensitivity | 3.2 | 7.1 | C | This requirement applies to receiver equipment. |
| 14 | Effective acceptance bandwidth | 3.2 | 7.2 | C | This requirement applies to transmitter equipment. |
| 15 | Adjacent channel rejection | 3.2 | 7.3 | C | This requirement applies to receiver equipment. |
| 16 | Spurious response rejection | 3.2 | 7.4 | C | This requirement applies to receiver equipment. |
| 17 | Intermodulation response rejection | 3.2 | 7.5 | C | This requirement applies to receiver equipment. |
| 18 | Blocking or desensitization | 3.2 | 7.6 | C | This requirement applies to receiver equipment. |
| 19 | Conducted spurious emissions | 3.2 | 7.7 | C | This requirement applies to receiver equipment. |
| 20 | Cross modulation rejection | 3.2 | 7.8 | C | This requirement applies to receiver equipment. |

| Harmonised Standard ETSI EN 302 617 | | | | | |
|-------------------------------------|------------------------|-------------------------------------|---|----------------------------|--|
| Requirement | | | | Requirement Conditionality | |
| No | Description | Essential requirements of Directive | Reference: Clause No(s) of the present document | U/C | Condition |
| 21 | Receiver dynamic range | 3.2 | 7.9 | C | This requirement applies to transmitter equipment. |
| 22 | Cabinet Radiation (RX) | 3.2 | 7.10 | C | This requirement applies to receiver equipment. |

Key to columns:

Requirement:

No A unique identifier for one row of the table which may be used to identify a requirement.

Description A textual reference to the requirement.

Essential requirements of Directive

Identification of article(s) defining the requirement in the Directive.

Clause-Number(s) of the present document

Identification of clause(s) defining the requirement in the present document unless another document is referenced explicitly.

Requirement Conditionality:

U/C Indicates whether the requirement is unconditionally applicable (U) or is conditional upon the manufacturer's claimed functionality of the equipment (C).

Condition Explains the conditions when the requirement is or is not applicable for a requirement which is classified "conditional".

Presumption of conformity stays valid only as long as a reference to the present document is maintained in the list published in the Official Journal of the European Union. Users of the present document should consult frequently the latest list published in the Official Journal of the European Union.

Other Union legislation may be applicable to the product(s) falling within the scope of the present document.

Annex B (normative): Specification for adjacent channel power measurement arrangements

B.1 Power measuring receiver specification

B.1.1 General

The power measuring receiver consists of a mixer, an Intermediate Frequency (IF) filter, and oscillator, an amplifier, a variable attenuator and an rmsRMS value indicator. Instead of the variable attenuator with the rmsRMS value indicator it is also possible to use an rmsRMS voltmeter calibrated in dB. The technical characteristics of the power measuring receiver are given below.

B.1.2 IF filter

The IF filter shall be within the limits of the following selectivity characteristics.

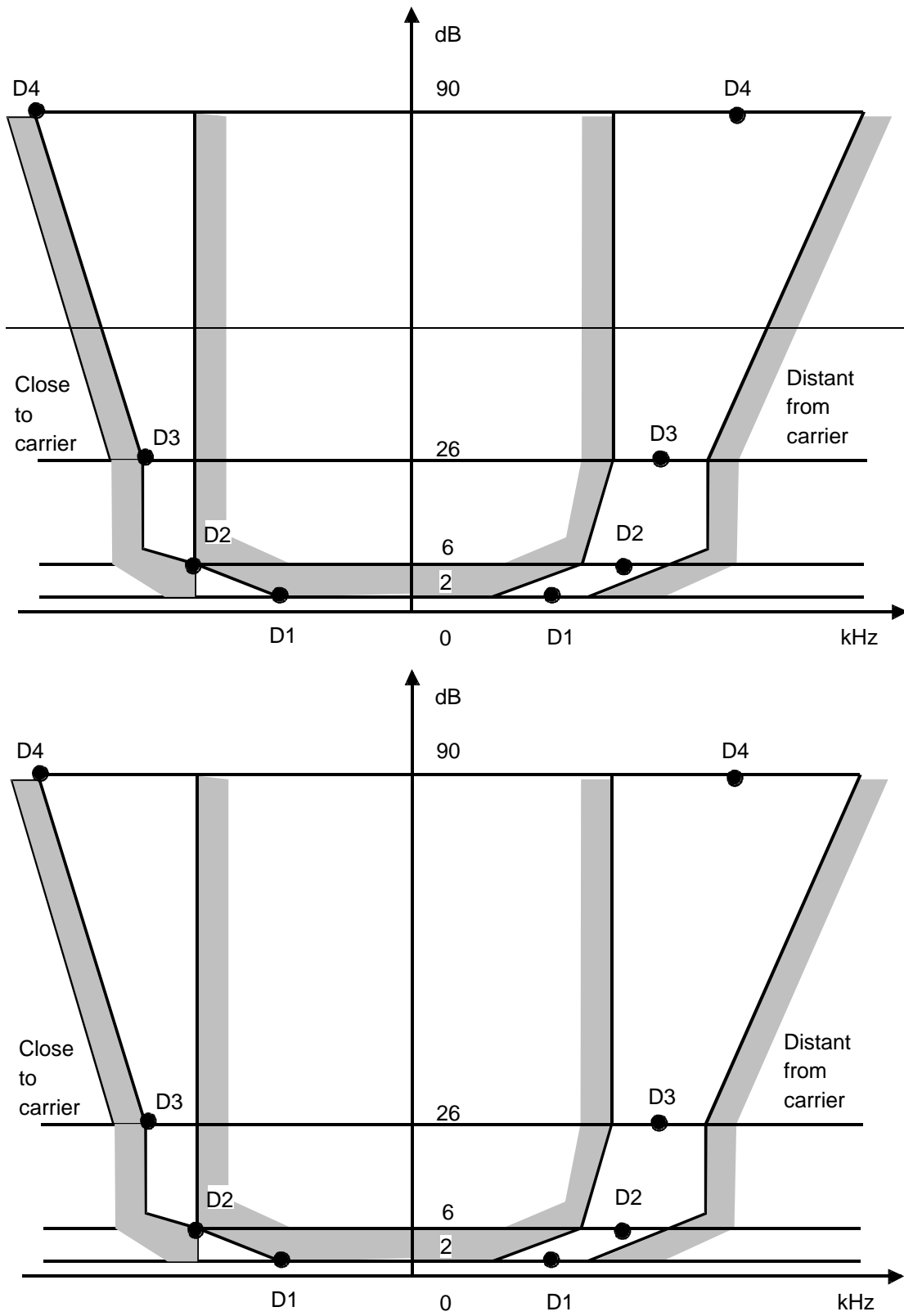

Figure B.1: Limits of the selectivity characteristic

The selectivity characteristic in table B.1 shall keep the following frequency separations from the nominal centre frequency of the adjacent channel.

Table B.1: Selectivity characteristic

| Frequency separation of filter curve from nominal centre frequency of adjacent channel (kHz) | | | | |
|--|----|----|------|-------|
| | D1 | D2 | D3 | D4 |
| 25 kHz Spacing | 5 | 8 | 9,25 | 13,25 |

The attenuation points listed in tables B.2 and B.3 shall not exceed the following tolerances.

Table B.2: Attenuation points close to carrier

| Tolerance range (kHz) | | | | |
|-----------------------|-----|------|-------|-------|
| | D1 | D2 | D3 | D4 |
| 25 kHz Spacing | 3,1 | ±0,1 | -1,35 | -5,35 |

Table B.3: Attenuation points distant from the carrier

| Tolerance range (kHz) | | | | |
|-----------------------|------|------|------|-----------|
| | D1 | D2 | D3 | D4 |
| 25 kHz Spacing | ±3,5 | ±3,5 | ±3,5 | +3,5/-7,5 |

The minimum attenuation of the filter outside the 90 dB attenuation points shall be equal to or greater than 90 dB.

B.1.3 Attenuation indicator

The attenuation indicator shall have a minimum range of 70 dB and a reading accuracy of 1 dB.

B.1.4 RMS value indicator

The instrument shall accurately indicate non-sinusoidal signals in a ratio of up to 10:1 between peak value and ~~rms~~RMS value.

B.1.5 Oscillator and amplifier

The crystal oscillator and the amplifier shall be designed in such a way that the measurement of the adjacent channel power of a low-noise unmodulated transmitter, whose self-noise has a negligible influence on the measurement result, yields a measured value of < -80 dB.

Annex C (informative): Auxiliary cables

The position of auxiliary cables (power supply and microphone cables, etc.) which are not adequately decoupled may cause variations in the measuring results. In order to get reproducible results, cables and wires of auxiliaries should be arranged vertically downwards (through a hole in the non-conducting support).

Annex D (informative): Change history

| Version | Information about changes |
|---------|---|
| 2.2.1 | Consolidated version of ETSI EN 302 617-1 (V1.1.1) and ETSI EN 302 617-2 (V2.1.1) |

History

| Document history | | |
|-------------------------|---------------------|--|
| V1.1.1 | January 2009 | Publication as ETSI EN 302 617 part 1 |
| V1.1.1 | October 2010 | Publication as ETSI EN 302 617 part 2 |
| V2.1.1 | December 2015 | Publication as ETSI EN 302 617 part 2 |
| V2.2.0 | May 2017 | EN Approval Procedure AP 20170820: 2017-05-22 to 2017-08-21 |
| V2.2.1 | November 2017 | Publication |
| <u>V2.3.0</u> | <u>March 2018</u> | <u>EN Approval Procedure AP 20180619: 2018-03-21 to 2018-06-19</u> |
| <u>V2.3.1</u> | <u>July 2018</u> | <u>Publication</u> |