



**Maritime ~~low power VHF personal~~survivor locating
~~beacons~~ devices employing Digital Selective Calling (DSC
Class M);
Harmonised Standard ~~covering the essential requirements for~~
access to radio spectrum and
~~of article 3.2 of Directive 2014/53/EU~~
for features for emergency services**

Reference

~~DENREN/ERM-TG26-408~~TGMAR-605

Keywords

harmonised standard, maritime, radio, SAR, testing

ETSI

650 Route des Lucioles
F-06921 Sophia Antipolis Cedex - FRANCE

Tel.: +33 4 92 94 42 00 Fax: +33 4 93 65 47 16

Siret N° 348 623 562 00017 - APE 7112B
Association à but non lucratif enregistrée à la
Sous-Préfecture de Grasse (06) N° w061004871

Important notice

The present document can be downloaded from:

<http://www.etsi.org/standards-search>

The present document may be made available in electronic versions and/or in print. The content of any electronic and/or print versions of the present document shall not be modified without the prior written authorization of ETSI. In case of any existing or perceived difference in contents between such versions and/or in print, the prevailing version of an ETSI deliverable is the one made publicly available in PDF format at www.etsi.org/deliver.

Users of the present document should be aware that the document may be subject to revision or change of status.

Information on the current status of this and other ETSI documents is available at

<https://portal.etsi.org/TB/ETSIDeliverableStatus.aspx>

If you find errors in the present document, please send your comment to one of the following services:

<https://portal.etsi.org/People/CommitteeSupportStaff.aspx>

If you find a security vulnerability in the present document, please report it through our
Coordinated Vulnerability Disclosure Program:

<https://www.etsi.org/standards/coordinated-vulnerability-disclosure>

Notice of disclaimer & limitation of liability

The information provided in the present deliverable is directed solely to professionals who have the appropriate degree of experience to understand and interpret its content in accordance with generally accepted engineering or other professional standard and applicable regulations.

No recommendation as to products and services or vendors is made or should be implied.

In no event shall ETSI be held liable for loss of profits or any other incidental or consequential damages.

Any software contained in this deliverable is provided "AS IS" with no warranties, express or implied, including but not limited to, the warranties of merchantability, fitness for a particular purpose and non-infringement of intellectual property rights and ETSI shall not be held liable in any event for any damages whatsoever (including, without limitation, damages for loss of profits, business interruption, loss of information, or any other pecuniary loss) arising out of or related to the use of or inability to use the software.

Copyright Notification

No part may be reproduced or utilized in any form or by any means, electronic or mechanical, including photocopying and microfilm except as authorized by written permission of ETSI.

The content of the PDF version shall not be modified without the written authorization of ETSI.

The copyright and the foregoing restriction extend to reproduction in all media.

© ETSI 2022.

All rights reserved.

Contents

Intellectual Property Rights	8
Foreword.....	8
Modal verbs terminology	9
1 Scope	10
2 References	10
2.1 Normative references	10
2.2 Informative references	11
3 Definition of terms, symbols and abbreviations.....	11
3.1 Terms	11
3.2 Symbols	12
3.3 Abbreviations.....	13
4 Requirements that can be visually inspected.....	13
4.0 Compliance	13
4.1 Construction	13
4.1.1 General	13
4.1.2 Categories of equipment.....	14
4.2 Controls.....	14
4.3 Indicators.....	14
4.3.1 General	14
4.3.2 Visual indicators.....	14
4.3.2.1 Alarm indicators	14
4.3.2.2 Test indicators	15
4.4 Self ID.....	15
4.5 Labelling	15
5 Technical information	15
5.1 Alerting and locating functions.....	15
5.2 Technical annexes.....	16
6 General conditions of measurement	16
6.1 Conformity testing	16
6.2 Unique identifier (self ID)	16
6.3 Artificial Antenna.....	16
6.3.1 For equipment with an integral antenna	16
6.3.2 For testing the RF transmitter output	16
6.3.3 For testing the DSC RF receiver input	16
6.4 Normal DSC TX Test Modulation.....	17
6.4.1 Continuous B / Y state	17
6.4.2 Alternating B-Y sequence	17
6.4.3 Random B-Y sequence.....	17
6.4.4 Unmodulated carrier.....	17
6.5 AIS TX Test Modulation	17
6.5.1 Standard test signal number 1	17
6.5.2 Standard test signal number 2	17
6.5.3 Standard test signal number 3	17
6.5.4 Unmodulated carrier.....	17
6.6 AIS Reference timing signal.....	17
6.7 Standard test signals for DSC receiver testing.....	18
6.8 Test conditions power sources and ambient temperatures	18
6.8.1 Normal and extreme test conditions	18
6.8.2 Test power sources	18
6.9 Normal test conditions.....	18
6.9.1 Normal temperature and humidity	18
6.9.2 Normal test voltage	18
6.10 Extreme test conditions.....	18
6.10.1 Extreme temperatures	18

6.10.2	Extreme test voltages	19
6.10.2.1	Upper extreme test voltage	19
6.10.2.2	Lower extreme test voltage.....	19
6.11	Reference Bandwidths for emission measurements.....	19
7	Environmental tests	19
7.1	Introduction.....	19
7.2	Procedure.....	19
7.3	Performance check.....	20
7.4	Drop test	20
7.4.1	Definition	20
7.4.2	Test conditions	20
7.4.3	Method of measurement.....	20
7.4.4	Required results.....	20
7.5	Temperature tests.....	21
7.5.1	Definition	21
7.5.2	Dry heat test	21
7.5.2.1	Method of measurement	21
7.5.2.2	Requirements	21
7.5.3	Damp heat test.....	21
7.5.3.1	Method of measurement	21
7.5.3.2	Required results	21
7.5.4	Low temperature test.....	22
7.5.4.1	Method of measurement	22
7.5.4.2	Required results	22
7.5.5	Low temperature battery endurance test.....	22
7.5.5.1	Method of measurement	22
7.5.5.2	Required results	22
7.6	Vibration test	22
7.6.1	Definition	22
7.6.2	Method of measurement.....	22
7.6.3	Required results.....	23
7.7	Saltwater spray test.....	23
7.7.1	Definition	23
7.7.2	Method of measurement.....	23
7.7.2.1	The spraying apparatus	23
7.7.2.2	Preparation of EUT.....	24
7.7.2.3	Test cycles	24
7.7.2.4	Conclusion of testing.....	24
7.7.3	Required results.....	24
7.8	Thermal shock test.....	24
7.8.1	Definition	24
7.8.2	Method of measurement.....	24
7.8.3	Required results.....	25
7.9	Buoyancy test.....	25
7.9.1	Definition	25
7.9.2	Method of measurement.....	25
7.9.3	Required results and limit	25
7.10	Protection of the transmitter.....	25
7.10.1	Definition	25
7.10.2	Method of measurement.....	25
7.10.3	Required results.....	25
8	Tests on the DSC transmitter	26
8.1	DSC Frequency error.....	26
8.1.1	Definition.....	26
8.1.2	Method of measurement.....	26
8.1.3	Limit.....	26
8.2	DSC Conducted power variation	26
8.2.1	Purpose	26
8.2.2	Definition.....	26
8.2.3	Method of measurement.....	26
8.2.4	Limit.....	26

8.3	Effective Radiated Power (ERP)	27
8.3.1	Definition.....	27
8.3.2	Method of measurement.....	27
8.3.3	Limits	27
8.4	DSC Adjacent channel power.....	27
8.4.1	Definition.....	27
8.4.2	Method of measurement.....	28
8.4.3	Limit	28
8.5	DSC Transmitter transient frequency behaviour.....	28
8.5.1	Definition.....	28
8.5.2	Method of measurement.....	29
8.5.3	Limit	32
8.6	Frequency error (demodulated DSC signal)	32
8.6.1	Definition	32
8.6.2	Method of measurement.....	32
8.6.3	Limit.....	32
8.7	Modulation index for DSC	32
8.7.1	Definition	32
8.7.2	Method of measurement.....	32
8.7.3	Limit.....	33
8.8	Modulation rate for DSC	33
8.8.1	Definition	33
8.8.2	Method of measurement.....	33
8.8.3	Limit.....	33
8.9	Spurious emissions	33
8.9.1	Definition.....	33
8.9.2	Method of measurement.....	33
8.9.3	Limit	34
9	Tests on the AIS transmitter	34
9.1	AIS Frequency error	34
9.1.1	Definition	34
9.1.2	Method of measurement.....	34
9.1.3	Limit.....	34
9.2	AIS Conducted power variation.....	34
9.2.1	Purpose.....	34
9.2.2	Definition	34
9.2.3	Method of measurement.....	34
9.2.4	Limit.....	35
9.3	AIS Transmitter spectrum mask	35
9.3.1	Definition	35
9.3.2	Method of measurement.....	35
9.3.3	Limit.....	36
9.4	AIS Transmitter transient behaviour (output power).....	36
9.4.1	Definition	36
9.4.2	Method of measurement.....	37
9.4.3	Limit.....	38
9.5	AIS Transmitter Transient Behaviour (frequency deviation)	38
9.5.1	Definition	38
9.5.2	Method of measurement.....	38
9.5.3	Limit.....	38
9.6	AIS Synchronization accuracy.....	39
9.6.1	Definition	39
9.6.2	Method of measurement.....	39
9.6.3	Limit.....	40
10	Tests on the DSC receiver	40
10.1	DSC Maximum usable sensitivity	40
10.1.1	Definition	40
10.1.2	Method of measurement.....	40
10.1.3	Limit	40
10.2	DSC Co-channel rejection	40
10.2.1	Definition	40

10.2.2	Method of measurement.....	41
10.2.3	Limit.....	41
10.3	DSC Adjacent channel selectivity	41
10.3.1	Definition	41
10.3.2	Method of measurement.....	41
10.3.3	Limit	41
10.4	DSC Spurious response	41
10.4.1	Definition	41
10.4.2	Spurious response frequency calculations.....	42
10.4.3	Method of measurement.....	42
10.4.4	Limit	42
10.5	DSC Intermodulation response	42
10.5.1	Definition	42
10.5.2	Method of measurement.....	42
10.5.3	Limit.....	43
10.6	Blocking or desensitization.....	43
10.6.1	Definition	43
10.6.2	Method of measurement.....	43
10.6.3	Limit	43
10.7	DSC Minimum dynamic range	43
10.7.1	Definition	43
10.7.2	Method of measurement.....	43
10.7.3	Limit	44
11	DSC Conformance Testing	44
11.1	Active mode tests.....	44
11.1.1	Listen Before Talk (LBT)	44
11.1.1.1	Method of measurement	44
11.1.1.2	Required Results.....	44
11.1.2	First closed loop distress transmissions.....	44
11.1.2.1	Applicability	44
11.1.2.2	Method of measurement	44
11.1.2.3	Required Results.....	44
11.1.3	First open loop distress transmissions	45
11.1.3.1	Applicability	45
11.1.3.2	Method of measurement	45
11.1.3.3	Required Results.....	46
11.1.4	Open loop distress repeat transmissions.....	46
11.1.4.1	Applicability	46
11.1.4.2	Method of measurement	47
11.1.4.3	Required Results.....	47
12	AIS VDL Link layer tests.....	47
12.1	Active mode tests.....	47
12.1.1	Method of measurement.....	47
12.1.2	Initialization period - Required results	48
12.1.3	Message content of Message 1 - Required results.....	48
12.1.4	Message content of Message 14 - Required results.....	48
12.1.5	Transmission schedule for Message 1 - Required results.....	49
12.1.6	Communication state of Message 1 - Required results	49
12.1.7	Transmission schedule of Message 14 - Required results	49
12.1.8	Transmission with lost GNSS - Required results	49
13	Testing for compliance with technical requirements.....	50
13.1	Environmental conditions for testing.....	50
Annex A (informative):	Relationship between the present document and the essential requirements of Directive 2014/53/EU	51
Annex B (normative):	Measuring receiver for adjacent channel power measurement	53
B.1	Power measuring receiver specification.....	53
B.1.1	General.....	53
B.1.2	IF filter.....	53

B.1.3	Attenuation indicator	54
B.1.4	r.m.s. value indicator.....	54
B.1.5	Oscillator and amplifier	54
Annex C (normative):	Additional Test Supports	55
C.1	Float-free support	55
Annex D (informative):	AIS message bursts	56
D.1	Active mode	56
D.2	Test mode	57
D.3	Default message field values.....	58
Annex E (informative):	Technical characteristics of class M MSLDs.....	59
E.1	General	59
E.2	DSC transmission characteristics	59
E.3	DSC messages and protocols	60
E.4	AIS transmission characteristics	60
E.4.1	General.....	60
E.4.2	AIS messages.....	60
E.4.2.1	General	60
E.4.2.2	Active mode	60
E.4.2.3	Test mode	60
E.4.3	Synchronization	61
E.4.3.1	General	61
E.4.3.2	Active mode	61
E.4.3.3	Test transmission.....	61
E.4.4	UTC	61
E.4.4.1	General.....	61
E.4.4.2	UTC parameters storage.....	62
E.4.5	Required settings	62
E.4.6	Minimum transmitter performance characteristics	62
E.4.7	VHF Data Link (VDL) Access	63
E.4.7.1	General	63
E.4.7.2	Active mode	63
E.4.7.3	Test mode	64
E.5	Position indication.....	64
E.6	Power source	64
E.7	Own vessel MMSI	64
Annex F (informative):	Grey-box testing of class M MSLDs.....	65
F.1	Definitions.....	65
F.2	Test interface	65
F.3	Test modes.....	65
F.3.1	Supported Modes	65
F.3.2	DSC Receiver test mode	66
Annex G (informative):	Maximum Measurement Uncertainty.....	67
Annex H (informative):	Checklist	68
Annex I (informative):	Change History	69
History		70

Intellectual Property Rights

Essential patents

IPRs essential or potentially essential to normative deliverables may have been declared to ETSI. The declarations pertaining to these essential IPRs, if any, are publicly available for **ETSI members and non-members**, and can be found in ETSI SR 000 314: "*Intellectual Property Rights (IPRs); Essential, or potentially Essential, IPRs notified to ETSI in respect of ETSI standards*", which is available from the ETSI Secretariat. Latest updates are available on the ETSI Web server (<https://ipr.etsi.org/>).

Pursuant to the ETSI Directives including the ETSI IPR Policy, no investigation regarding the essentiality of IPRs, including IPR searches, has been carried out by ETSI. No guarantee can be given as to the existence of other IPRs not referenced in ETSI SR 000 314 (or the updates on the ETSI Web server) which are, or may be, or may become, essential to the present document.

Trademarks

The present document may include trademarks and/or tradenames which are asserted and/or registered by their owners. ETSI claims no ownership of these except for any which are indicated as being the property of ETSI, and conveys no right to use or reproduce any trademark and/or tradename. Mention of those trademarks in the present document does not constitute an endorsement by ETSI of products, services or organizations associated with those trademarks.

DECT™, **PLUGTESTS™**, **UMTS™** and the ETSI logo are trademarks of ETSI registered for the benefit of its Members. **3GPP™** and **LTE™** are trademarks of ETSI registered for the benefit of its Members and of the 3GPP Organizational Partners. **oneM2M™** logo is a trademark of ETSI registered for the benefit of its Members and of the oneM2M Partners. **GSM®** and the GSM logo are trademarks registered and owned by the GSM Association.

Foreword

This Harmonised European Standard (EN) has been produced by ETSI Technical Committee Electromagnetic compatibility and Radio spectrum Matters (ERM).

The present document has been prepared under the Commission's standardisation request C(2015) 5376 final [i.7**Error! Reference source not found.**] to provide one voluntary means of conforming to the essential requirements of Directive 2014/53/EU on the harmonisation of the laws of the Member States relating to the making available on the market of radio equipment and repealing Directive 1999/5/EC [i.1].

Once the present document is cited in the Official Journal of the European Union under that Directive, compliance with the normative clauses of the present document given in table A.1 confers, within the limits of the scope of the present document, a presumption of conformity with the corresponding essential requirements of that Directive and associated EFTA regulations.

National transposition dates

Date of adoption of this EN:	<u>14 October 2022</u>
Date of latest announcement of this EN (doa):	31 <u>January 2023</u>
Date of latest publication of new National Standard or endorsement of this EN (dop/e):	<u>31 July 2023</u>
Date of withdrawal of any conflicting National Standard (dow):	<u>31 July 2024</u>

Modal verbs terminology

In the present document "**shall**", "**shall not**", "**should**", "**should not**", "**may**", "**need not**", "**will**", "**will not**", "**can**" and "**cannot**" are to be interpreted as described in clause 3.2 of the [ETSI Drafting Rules](#) (Verbal forms for the expression of provisions).

"**must**" and "**must not**" are **NOT** allowed in ETSI deliverables except when used in direct citation.

1 Scope

The present document ~~lays down the minimum requirements~~ specifies technical characteristics and methods of measurements for low power maritime personal locating beacons Maritime Survivor Locating Devices (MSLDs) (man overboard devices) employing class M DSC signalling and AIS position locating signalling according to ETSI EN 300 338-6 [1], on the VHF maritime mobile frequency band channel channels 70. Maritime personal locating beacons employing DSC signalling also include AIS with an integrated GNSS receiver to provide the locating function, AIS 1 and AIS 2.

Class M MSLD (man overboard devices) are included in group A Autonomous Maritime Radio Devices (AMRDs) according to ~~ETSI EN 303 098~~ Recommendation ITU-R M.2135.0 [2]. The present document incorporates the relevant provisions of the International Telecommunication Union (ITU) radio regulations [1.4] included in Recommendation ITU-R M.493-14 [3]. ~~The present document does not cover requirements for the integrated GNSS receiver providing the locating function.~~ [15] [2] and Recommendation ITU-R M.1371-5 [i.7].

LBT (Listen Before Talk) techniques are employed to improve spectrum efficiency.

~~For this application, both the radiated power and the length of time of operation are limited to enable the equipment to be sufficiently small and light to be worn comfortably at all times and to limit the operating range to a local area.~~

~~The present document also specifies~~ does not provide technical characteristics, methods of measurement and required test results.

~~The present document covers~~ requirements for conformance with the essential requirements of article 3.2 of Directive 2014/53/EU [i.1.1] under the conditions identified in annex A for any integrated GNSS receiver providing locating function.

NOTE: The relationship between the present document and essential requirements of article 3.2 and 3.3(g) of Directive 2014/53/EU [i.1] is given in annex A.

2 References

2.1 Normative references

References are either specific (identified by date of publication and/or edition number or version number) or non-specific. For specific references, only the cited version applies. For non-specific references, the latest version of the referenced document (including any amendments) applies.

Referenced documents which are not found to be publicly available in the expected location might be found at <https://docbox.etsi.org/Reference>.

NOTE: While any hyperlinks included in this clause were valid at the time of publication, ETSI cannot guarantee their long term validity.

The following referenced documents are necessary for the application of the present document.

- [1] ETSI EN 300 338-6 (V1.2.1.1) ~~(02-2017)~~ (06-2020): "Technical characteristics and methods of measurement for equipment for generation, transmission and reception of Digital Selective Calling (DSC) in the maritime MF, MF/HF and/or VHF mobile service; Part 6: Class M DSC".
- [2] ~~ETSI EN 303 098 (V2.1.1) (05-2016): "Maritime low power personal locating devices employing AIS; Harmonised Standard covering the essential requirements of article 3.2 of Directive 2014/53/EU".~~
- [3] ~~Recommendation ITU-R M.493-14 (09/2015)~~ 15 (01-2019): "Digital selective-calling system for use in the maritime mobile service".
- [3] ~~IMO Annex 11 Resolution MSC.149 (77) (adopted on 3 June 2003): "Adoption of the revised performance standards for survival craft portable two way VHF radiotelephone apparatus".~~

- [5] ~~ETSI EN 301 025 (V2.2.1) (03-2017): "VHF radiotelephone equipment for general communications and associated equipment for Class "D" Digital Selective Calling (DSC); Harmonised Standard covering the essential requirements of articles 3.2 and 3.3(g) of Directive 2014/53/EU".~~
- [6] ETSI TS 103 052 (V1.1.1) (03-2011): "Electromagnetic compatibility and Radio spectrum Matters (ERM); Radiated measurement methods and general arrangements for test sites up to 100-GHz".
- [4] Recommendation ITU-T O.153 (10-1992): "Basic parameters for the measurement of error performance at bit rates below the primary rate".
- [5] IEC 60945 (2002 with COR1:2008): "Maritime Navigation and Radiocommunication Equipment and Systems - General Requirements - Methods of Testing and Required Test Results".

2.2 Informative references

References are either specific (identified by date of publication and/or edition number or version number) or non-specific. For specific references, only the cited version applies. For non-specific references, the latest version of the referenced document (including any amendments) applies.

NOTE: While any hyperlinks included in this clause were valid at the time of publication, ETSI cannot guarantee their long term validity.

The following referenced documents are not necessary for the application of the present document but they assist the user with regard to a particular subject area.

- [i.1] Directive 2014/53/EU of the European Parliament and of the Council of 16 April 2014 on the harmonisation of the laws of the Member States relating to the making available on the market of radio equipment and repealing Directive 1999/5/EC.
- [i.2] ~~ETSI TR 100 028-1 (V1.4.1) (12-2001): "Electromagnetic compatibility and Radio spectrum Matters (ERM); Uncertainties in the measurement of mobile radio equipment characteristics; Part 1".~~
- [i.3] ~~ETSI TR 100 028-2 (V1.4.1) (12-2001): "Electromagnetic compatibility and Radio spectrum Matters (ERM); Uncertainties in the measurement of mobile radio equipment characteristics; Part 2".~~
- [i.4] ~~ITU-R Radio Regulations (2016)~~
- [i.5] ~~ETSI TS 101 570-2 (V1.1.1): "Electromagnetic compatibility and Radio spectrum Matters (ERM); Interoperability Testing for Maritime Digital Selective Calling (DSC) Radios; Part 2: Class A/B Test Descriptions".~~
- [i.6] ~~ETSI TS 101 570-3 (V1.1.1): "Electromagnetic compatibility and Radio spectrum Matters (ERM); Interoperability Testing for Maritime Digital Selective Calling (DSC) Radios; Part 3: Class D Test Descriptions".~~
- [i.7] Commission Implementing Decision C(2015) 5376 final of 4.8.2015 on a standardisation request to the European Committee for Electrotechnical Standardisation and to the European Telecommunications Standards Institute as regards radio equipment in support of Directive 2014/53/EU of the European Parliament and of the Council.
- [i.3] ETSI EG 203 336 (V1.2.1): "Guide for the selection of technical parameters for the production of Harmonised Standards covering article 3.1(b) and article 3.2 of Directive 2014/53/EU".
- [i.4] ITU-R Radio Regulations (2020)
- [i.5] ETSI TS 101 570-6 (V1.1.1): "Interoperability Testing for Maritime Digital Selective Calling (DSC) Radios; Part 6: VHF Class M Test Descriptions".
- [i.6] Recommendation ITU-R M.2135.0 (10/2019): "Technical characteristics of autonomous maritime radio devices operating in the frequency band 156-162.05 MHz".

- [i.73] ~~Definitions~~ Recommendation ITU-R M.1371-5 (02/2014): "Technical characteristics for an automatic identification system using time-division multiple access in the VHF maritime mobile band".
- [i.8] Recommendation ITU-R M.585-8 (10/2019): "Assignment and use of identities in the maritime mobile service".
- [i.9] IMO Annex 11 - Resolution MSC.149 (77) - (adopted on 3 June 2003): "Adoption of the revised performance standards for survival craft portable two-way VHF radiotelephone apparatus".
- [i.10] EUROCAE ED-14G: "Environmental conditions and test procedures for airborne equipment".
- [i.11] IEC EN 60068-2-64:2008/A1:2019: "Environmental testing - Part 2-64: Tests - Test Fh: Vibration, broadband random and guidance".

3 Definition of terms, symbols and abbreviations

3.1 ~~Definitions~~ Terms

For the purposes of the present document, the following terms and definitions apply:

acknowledged: automated procedure it indicates that the objective of the initial DSC message has been achieved

activation: initial triggering of the MOB device ~~an MSLD~~ i.e. both parts of the two-step procedure are performed

active mode: activated mode, transmitting in an emergency situation

closed loop: individual transmission to own vessel

dedicated antenna: removable antenna supplied and tested with the equipment, designed as an indispensable part of the equipment

default: value selected or an action taken by the equipment software in the absence of any operator input

distress alert: name given to the single distress DSC message with the format symbol 112

distress DSC message: DSC message or acknowledgement containing the distress information

distress information: symbols within a DSC message describing a distress situation consisting of the MMSI of the vessel in distress, the nature of distress, the position of the vessel in distress, the UTC time of that position and the mode of subsequent communication

factory default: default value that is set by the manufacturer such that the field or behaviour is defined prior to any operator intervention

information characters: set of symbols in a DSC message that contains the items of interest for the recipient and is used to compute the ECC symbol that terminates the message

integral antenna: antenna designed to be connected to the equipment without the use of a 50 Ω external connector and considered to be part of the equipment

NOTE: An integral antenna may be fitted internally or externally to the equipment.

non distress DSC message: DSC messages or acknowledgements that do not have the format specifier or category of "distress"

open loop: transmitting to all ships (broadcast)

personal floatation device: buoyancy aid, life jacket or vest worn by person

symbol (as part of the DSC sentence): 7 binary bits of a 10 bit DSC word that have the information content

test mode: self-testing mode, an individual test call to own vessel

UTC lock: GNSS has precisely locked to UTC so that it can determine SOTDMA slot timing correctly

UTC parameters: "Coordinated Universal Time (UTC) offset parameters" GNSS data that contains leap second offset information

word (as part of the DSC sentence): used to describe the 10 binary bits that make up the coded entities of a transmitted DSC message

NOTE: The 10 bits consist of a 7 bit "symbol" that gives the information content and 3 bit error check that gives the number of 0 binary bits in the 7 bit symbol.

3.2 Symbols

For the purposes of the present document, the following symbols apply:

<u>cSt</u>	centi-Stokes
<u>dB</u>	decibel
<u>dBc</u>	Decibels referenced to the carrier power
<u>dBm</u>	Decibels referenced to 1 milliwatt
<u>dBμV</u>	dB refence to 1 μ V (e.m.f)
<u>GHz</u>	GigaHertz
<u>kHz</u>	kiloHertz
<u>MHz</u>	MegaHertz
<u>ms</u>	milliseconds
<u>mW</u>	milliWatts
<u>nW</u>	NanoWatts
<u>P_{Norm}</u>	conducted power measured under normal conditions
<u>P_{.20}</u>	conducted power measured at the lower extreme temperature
<u>P₊₅₅</u>	conducted power measured at the upper extreme temperature
<u>pps</u>	pulses per second
<u>μT</u>	microtesla
<u>μW</u>	MicroWatts

3.3 Abbreviations

For the purposes of the present document, the following abbreviations apply:

<u>AIS</u>	Automatic Identification System
<u>AMRD</u>	Autonomous Maritime Radio Device
<u>CIRM</u>	Comité International Radio-Maritime
<u>COG</u>	Course Over Ground
<u>CRC</u>	Cyclic Redundancy Check
<u>CSP</u>	Channel SPacing
<u>DSC</u>	Digital Selective Calling
<u>EIRP</u>	Effective Isotropic Radiated Power
<u>EN</u>	European Norm
<u>ERP</u>	Effective Radiated Power
<u>EUT</u>	Equipment Under Test
<u>FM</u>	Frequency Modulation
<u>FSK</u>	Frequency Shift Keying
<u>GLONASS</u>	GLObal NAVigation Satellite System
<u>GMDSS</u>	Global Maritime Distress and Safety System
<u>GMSK</u>	Gaussian Minimum Shift Keying
<u>GNSS</u>	Global Navigation Satellite System
<u>GPS</u>	Global Positioning System
<u>ID</u>	Identity
<u>IERS</u>	International Earth Reference and Rotation System Service
<u>IMO</u>	International Maritime Organization
<u>LBT</u>	Listen Before Talk
<u>MMSI</u>	Maritime Mobile Service Identity
<u>MOB</u>	Man Over-Board

MSC	Maritime Safety Committee
<u>MSLD</u>	<u>Maritime Survivor Locating Device</u>
<u>NRZI</u>	<u>Non Return to Zero, Inverted</u>
<u>OOB</u>	<u>Out Of Band</u>
<u>RAIM</u>	<u>Receiver Autonomous Integrity Monitoring</u>
RBW	Reference BandWidth
RF	Radio Frequency
SINAD	(Signal+Noise+Distortion) to (Noise + Distortion)
<u>SOG</u>	<u>Speed Over Ground</u>
<u>SOTDMA</u>	<u>Self-Organized Time Division Multiple Access</u>
<u>TDMA</u>	<u>Time Division Multiple Access</u>
UTC	Coordinated Universal Time
<u>VDL</u>	<u>VHF Data Link</u>
VHF	Very High Frequency
VSWR	Voltage Standing Wave Ratio

4 General Requirements that can be visually inspected

4.0 Compliance

Compliance to the requirements of this clause (clause 4) shall be achieved by inspection of the supplied user documentation and by simple inspection of the equipment.

4.1 Construction

4.1.1 General

~~The manufacturer shall declare that compliance to the requirements of this clause (clause 4) is achieved and shall provide relevant documentation.~~

~~In all respects, the mechanical and electrical design and the construction and finish of the equipment shall conform with good engineering practice.~~

~~The equipment shall be designed to minimize the risk of internal and external damage during use or stowage.~~

~~The exterior of the equipment shall should have no sharp edges or projections that could easily damage inflatable rafts or injure personnel so as to minimize the risk of internal and external damage during use or stowage.~~

~~The general construction and method of operation shall provide a high degree of proof against inadvertent operation due to nominal levels of: magnetic influences, handling, stowage and transit, whilst still providing a simple means of operation in an emergency.~~

~~The equipment shall be portable, lightweight, compact and be designed as one integral unit. The ~~locating beacon~~ MSLD shall derive its energy from a battery forming a part of the equipment and incorporate a permanently attached antenna which may be either fixed length or extendible.~~

~~The ~~locating beacon~~ may be fitted a detachable antenna that is supplied with a test facility by which the functioning of the transmitter and battery can be easily tested without the use of any external equipment.~~

~~The equipment shall be capable of being used by an unskilled person.~~

~~The ~~locating beacon~~ shall be watertight.~~

~~The equipment shall not be unduly affected by sea water or oil and shall be resistant to deterioration by prolonged exposure to sunlight.~~

~~A substantial part for fitting in a personal floatation device. At least 50 % of the equipment shall be of highly visible yellow or orange colour to assist visual location.~~

4.1.2 Categories of equipment

Two categories are defined:

- Category 1 ~~locating beacons shall have~~ MSLDs with sufficient positive buoyancy to float in fresh water, (see clause 7.9 for the buoyancy test).
- Category 2 ~~locating beacons~~ MSLDs intended to be incorporated into or attached to a buoyancy aid (personal floatation device) are not required to float.

Category 1 ~~beacons~~ MSLDs that can float free may have a lanyard to attach them to a person or life vest, personal floatation device. Where a lanyard is employed it ~~shall~~ should meet the requirements of IMO MSC 149(77) [i.9], paragraph 2.3.11. The user manual or instructions shall include necessary information to allow the user to properly attach the ~~locating beacon~~ lanyard.

The user manual or instructions for Category 2 ~~beacons~~ MSLDs shall include necessary information to allow the user to fit or attach the ~~locating beacon~~ MSLD to a buoyancy aid, personal floatation device.

4.2 Controls

The equipment shall be initially activated by the use of two simple, but independent mechanical actions, neither of which on its own shall activate the equipment. ~~The~~ If the second mechanical action may be replaced by an immersion sensor. ~~Where the second action is replaced by an immersion sensor, then the first~~ mechanical action shall ~~shall~~ should be an arming or enabling function thus to ensure the ~~beacon~~ MSLD is armed for automatic activation when submerged.

It ~~shall~~ should only be possible to activate the equipment after a seal or other mechanical restraint has been removed from the first mechanical action. ~~For beacons without an arm function it shall not be possible to reattach a removed seal or restraint~~. After activation it shall be simple to de-activate the equipment and the means to deactivate the equipment shall be clearly marked. It should be possible to determine that the equipment has been previously activated, either by the absence of a seal or restraint or by a non-resettable electronic circuit by providing a clear optical indication for the user.

The switch that operates any test facility ~~(see clause 4.1)~~ shall be so designed that it returns automatically to the off-position when released.

4.3 Indicators

4.3.1 General

The equipment shall be provided with visual ~~and, with the exception of intrinsically safe MOB devices, audible~~ indications ~~that~~ to show the operation of the MOB device MSLD as specified in clause 4.3.2.

4.3.2 Audible indicators

The ~~equipment may also be provided with~~ audible indicator shall clearly distinguish ~~indications that show the following:~~

- 1) ~~Initial activation~~ operation of the ~~locating beacon~~ MSLD.
- 2) ~~Immediately prior to the locating beacon transmitting~~.

4.3.3 Visual indicators

4.3.2.1 Alarm indicators

The visual indicator shall ~~be sufficiently bright to be seen~~ clearly distinguish the following states with each indicator being described in bright sunlight and clearly distinguish the following states the user manual:

- i) The ~~locating beacon~~ MSLD has been activated and is transmitting in active mode.

- ii) ~~The locating beacon~~MSLD has GNSS position lock and is transmitting in active mode.
- iii) ~~The locating beacon~~iii) The MSLD has received a DSC acknowledgement and the DSC transmitter has been deactivated remotely.
- iv) The MSLD is idle and has been deactivated locally.

4.3.2.2 Test indicators

In addition the visual indicator should also clearly distinguish the following states:

- i) The MSLD is undergoing test and is transmitting in test mode.
- iv) ~~The locating beacon has completed a test or has been deactivated locally.~~
- v) ~~The locating beacon~~ii) The MSLD cannot complete a test because it has not been properly programmed with own vessel MMSI- (for closed loop devices only).
- viii) ~~The locating beacon~~MSLD cannot complete a test because it could not obtain a GNSS position.
- viii)iv) ~~The locating beacon~~MSLD has received a ~~DSC~~test acknowledgement ~~and the DSC transmitter has been deactivated remotely~~ as defined in Recommendation ITU-R M.493-15 [2] table A1-4.7 (a momentary indication each time a test acknowledgement is received during testing to clause 10).

4.4 Self ID

~~The locating beacon~~MSLDs shall have a freeform number identity (self ID) to distinguish ~~it~~them from other DSC devices.

The self ID for a ~~personal locating beacon~~an MSLD is 972xyyyy, where xx = manufacturer ID 01 to 99; yyyy = the sequence number 0000 to 9999 allocated by the manufacturer, as specified in Recommendation ITU-R M.585-8 [i.8], section 2.2 of annex 2. Manufacturers IDs are issued by CIRM (www.cirm.org). Manufacturers shall only use manufacturer IDs that have been issued to them by CIRM, except for training and conformance testing purposes where the ID xx=00 can be used.

The self ID is tested in clause 12.

After being programmed by the manufacturer, it ~~shall~~should not be possible for the user to change the self ID of ~~the locating beacon~~an MSLD.

~~The self ID shall be held in non-volatile memory.~~

4.5 ~~Own vessel MMSI~~

~~The locating beacon shall be programmed with the MMSI of its own vessel or group.~~

~~It shall be possible for a locating beacon's own vessel MMSI to be re-programmed in the field, for example when locating beacons are moved from one vessel to be stowed on another vessel. It shall be possible for users to re-programme the own vessel MMSI without locating beacons having to be returned to the manufacturer.~~

~~The own vessel MMSI shall be held in non-volatile memory.~~

~~If the own vessel MMSI is not entered or not valid the locating beacon shall indicate this during test.~~

4.6 ~~Labelling~~

The ~~locating beacon~~MSLD shall be provided with a label, or labels, permanently affixed to the exterior of the equipment, containing the following information:

- Self ID of the equipment (see clause 4.4).
- Open loop devices shall be marked DSC-MOB-O.

- Closed loop devices shall be marked DSC-MOB-C.
- Adequate instructions to enable the equipment to be activated and deactivated.
- The type of battery as specified by the manufacturer of the ~~locating beacon~~ MSLD.
- A warning to not block the GNSS antenna.
- The compass safe distance as measured in clause ~~7.10~~, 11.2 of IEC 60945 [5].
- A warning to the effect that the ~~radio beacon~~ MSLD should not be operated except in an emergency.
- The date on which the battery will need to be replaced. ~~Simple means shall be provided for changing this date when the battery is replaced. The battery replacement date marked on the locating beacon should be the date specified in clause 4.9.1. (the expiry date of the battery).~~

4.7 — Instructions

Necessary operating instructions shall be provided with the equipment. These should include the following warnings:

- ~~"WARNING — This equipment is for use in an emergency only. It is not intended for routine tracking of persons or property. This includes routine recovery of divers"~~.
- ~~"WARNING — If self test is performed more frequently than once a month, then battery life may be reduced"~~.

4.8 — Position indication

DSC MOB locating beacons use AIS MOB functionality to indicate their current position. The equipment shall incorporate position reporting as described in clause 5.2.3 of ETSI EN 303 098 [2]. Where the requirements of clause 4 of ETSI EN 303 098 [2] conflict with the requirements of the present document, the requirements of the present document shall take precedence.

4.9 — Power source

4.9.1 — Battery requirements

The type of battery and designation specified by the manufacturer for use in the equipment shall be clearly and indelibly marked on the equipment.

~~The manufacturer should establish a useful life and an expiry date for primary (non-rechargeable) batteries. The useful life is the period of time after the date of battery manufacture that the battery will continue to meet the input power requirements of the locating beacon, over the entire specified operating temperature range. The following losses shall be included (at a temperature of $+20\text{ °C} \pm 5\text{ °C}$):~~

- ~~a) self testing annually with GNSS data available;~~
- ~~b)a) self discharge of the battery;~~
- ~~e)a) stand-by loads.~~

~~The expiry date of the battery shall be the battery installation date plus no more than half the useful life of the battery. The battery shall have a minimum useful life of at least two years. The installation date shall be no more than one year from the date of manufacture of the battery. The battery shall be clearly and durably marked with its date of manufacture. The locating beacon shall be clearly marked with the expiry date of the battery.~~

4.9.2 — Battery capacity

~~The battery, after having met the requirements of clause 4.9.1 shall have sufficient remaining capacity to power an activated locating beacon and keep it transmitting for at least 12 hours at a temperature of $-20\text{ °C} \pm 3\text{ °C}$.~~

4.9.3 Safety precautions

Provisions shall be made for protecting the equipment from damage due to the accidental reversal of polarity of the battery.

5 Technical requirements information

5.1 General

When activated the locating beacon shall be capable of transmitting distress messages that indicate the position of a person in the water. The transmitted messages shall be compatible with Table A1-4.1, Table A1-4.3 and Table A1-4.7 of Recommendation ITU-R M.493-14 [3] DSC class M. DSC messages are transmitted on maritime VHF channel 70 (156,525 MHz). Transmission shall only commence if the channel is not busy (Listen Before Talk). The locating beacon shall have an integral DSC receiver capable of receiving distress acknowledgements. On receipt of a properly addressed distress acknowledgement the locating beacon shall stop transmitting and indicate that the distress alert has been acknowledged.

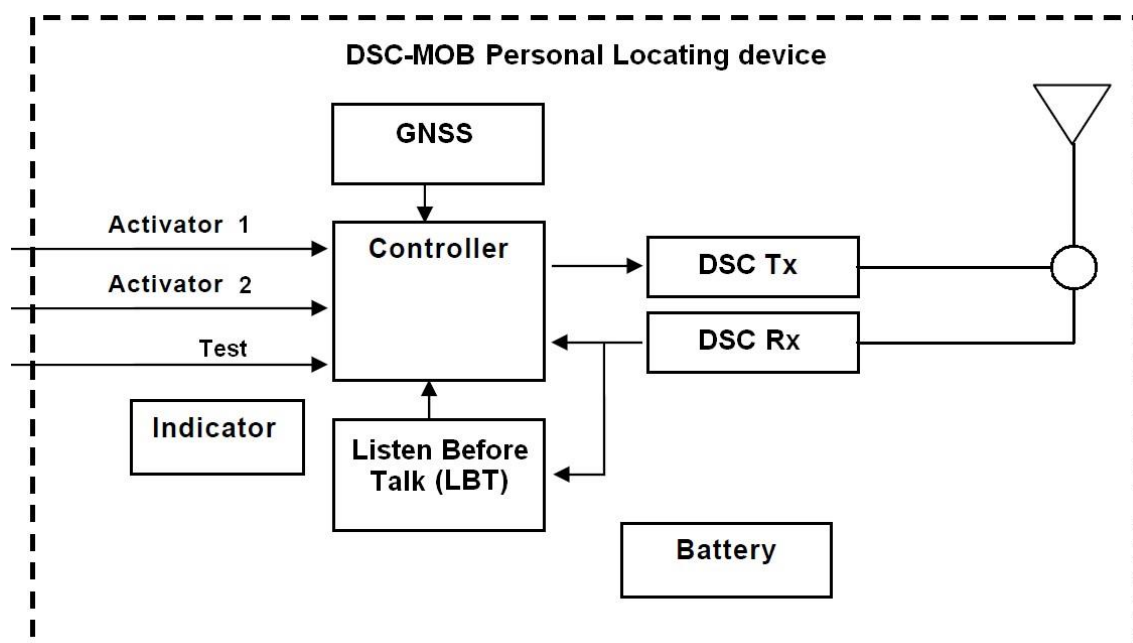

Figure 1: Functional block diagram of personal locating beacon

5.2 DSC transmission characteristics

The locating beacon transmits on marine VHF channel 70 (156,525 MHz) using DSC signalling (phase modulated G2B) as defined in clause 1.3.2 of Annex 1 of Recommendation ITU-R M.493-14 [3].

Table 1 is derived from Recommendation ITU-R M.493-14 [3] and give the parameters required for a DSC locating beacon.

Table 1: Required parameter settings

Symbol	Parameter name	Setting
CH70	Marine band channel 70	156,525 MHz
ϕM	Frequency modulation with a pre-emphasis characteristic of 6 dB/octave (phase modulation) with a modulating sub-carrier shall be used	Pre-emphasis time constant 750 μ S
FSK	Sub-carrier modulation 1 300 Hz (Y-state) and 2 100 Hz (B-state) shall be used	Sub-carrier tolerance \pm 10 Hz
	Modulation index	$2,0 \pm 10\%$
	Modulation rate	1-200 baud
	Transmitter output power	100 mW to 500 mW ERP

Because DSC MOB locating beacons transmit with significantly lower power than other DSC devices, DSC MOB locating beacons shall first listen to the VHF channel 70 to ensure that it is not being used, before transmitting. ~~The protocol for this is described in clause 5.1 of ETSI EN 300 338 6 [1].~~

5.3 ~~DSC messages~~ Alerting and protocols ~~locating functions~~

DSC message content and use differs for active transmissions (active mode) and test transmissions (test mode). Both modes are specified in clause 5.2 of ETSI EN 300 338 6 [1].

5.4 ~~Position indication~~

~~The locating beacon shall have an integral GNSS receiver as specified in clause 6 of ETSI EN 300 338 6 [1]. The locating beacon shall use this source to provide position information in the DSC distress messages it transmits. Locating beacons are not permitted to reply to position requests using DSC signalling, but shall instead indicate their position using AIS signalling as specified in clause 5 of ETSI EN 303 098 [2].~~

Class M MSLDs shall contain:

- i) a DSC transmitter operating on maritime VHF channel 70 (156,525 MHz) for the alerting function;
- ii) a DSC receiver listening to channel 70 to allow the device to be remotely deactivated;
- iii) an AIS transmitter using modified SOTDMA and operating on channels AIS1 (161,975 MHz) and AIS2 (162,025 MHz) for the locating function;
- iv) a GNSS receiver for position determination and as an AIS SOTDMA timing reference.

The alerting function is tested in clauses 8, 10 and 11. The locating function is tested in clauses 9 and 12.

The two basic functions may or may not use common transmitting circuits and antennas.

5.2 Technical annexes

Annex E describes the technical characteristics of class M MSLDs in sufficient detail to allow a skilled person to understand the basic operation of the equipment being tested.

Annex F describes the grey-box testing requirements that manufacturers need to implement and disclose so that MSLDs can be tested to the present document.

6 General conditions of measurement

6.1 Conformity testing

For the purpose of conformity testing, clauses 6.2 to 6.6 ~~11~~ shall apply.

6.2 ~~Test Frequencies~~

~~Channel 70 shall be used as the test channel. Where radiated measurements are not performed in an anechoic chamber an alternative channel other than channel 70 shall be used during testing to avoid interference with live maritime systems. Where an alternative channel is used the alternative frequency used shall be within $\pm 1\%$ of 156,525 MHz and the frequency used shall be recorded~~

6.3 Unique identifier (self ID)

The manufacturer ID xx = 00 is reserved for training and conformance test purposes. The unique identifier used during testing to the present document shall be in the format 97200yyyy.

6.4.3 Artificial Antenna

~~Where applicable,~~ 6.3.1 For equipment with an integral antenna

In the case of equipment with an integral antenna a 50 Ω antenna connector shall be used in place of the integral antenna to facilitate conducted testing.

6.3.2 For testing the RF transmitter output

Tests specified as conducted tests shall be carried out using an artificial antenna which shall be a substantially non-reactive non-radiating load connected to the antenna connector. The Voltage Standing Wave Ratio (VSWR) at the 50 Ω connector or the manufacturer's specified test fixture shall not be greater than 1,5:1 over the frequency range of the measurement.

~~In the case of integral antenna equipment, if the equipment does not have an internal permanent 50 Ω connector then it is permitted to supply a second sample of the equipment with a temporary 50 Ω antenna cable and connector fitted to facilitate testing.~~

6.5 Transmitters may have limitations concerning their maximum continuous transmit time and/or their transmission duty cycle. It is intended that such limitations are respected during testing.

6.3.3 For testing the DSC RF receiver input

Test signal sources shall be combined and connected to the antenna port in such a way that the impedance presented to the receiver input is 50 Ω with a VSWR less than 1,5:1, irrespective of whether one or more test signals are applied to the receiver simultaneously.

The levels of the test signals shall be expressed in terms of the power (dBm) at the terminals to be connected to the receiver.

The nominal frequency of the receiver is the carrier frequency of the selected channel.

6.4 Normal DSC TX Test Modulation

~~For normal test modulation, the modulation frequency shall be 1 kHz and the frequency deviation shall be ± 3 kHz.~~

6.4.1 Continuous B / Y state

For DSC conformance testing purposes only, the equipment shall have facilities to generate a continuous B or Y modulation state.

6.4.2 Alternating B-Y sequence

For DSC conformance testing purposes only, the equipment shall have facilities to generate a continuous dot pattern comprising an alternating B-Y sequence.

6.4.3 Random B-Y sequence

For DSC conformance testing purposes only, the equipment shall have facilities to generate a continuous pseudo-random pattern comprising a 511-bit pseudo-random B-Y sequence as specified in clause 2.1 of Recommendation ITU-T O.153 [4].

6.4.4 Unmodulated carrier

Additionally for conformance testing only, the equipment shall have facilities ~~not accessible to the operator to generate a continuous B or Y signal and dot pattern.~~

Additionally for conformance testing, the VHF equipment shall have facilities ~~not accessible to the operator for generating an unmodulated carrier.~~

6.5 AIS TX Test Modulation

6.5.1 Standard test signal number 1

For AIS conformance testing purposes, the equipment shall have facilities to generate a series of reversals 010101... transmitted as all the bits within an AIS message frame, including header, start flag, end flag and CRC. NRZI is not applied to the reversals or Cyclic Redundancy Check (CRC), i.e. unaltered "On Air" data. The RF should be ramped up and down on either end of the AIS test message frame.

6.5.2 Standard test signal number 2

For AIS conformance testing purposes, the equipment shall have facilities to generate a series of 00001111... repeated as the data within an AIS message frame, including header, start flag, end flag and CRC. NRZI is not applied to the data or CRC. The RF should be ramped up and down on either end of the AIS message frame.

6.5.3 Standard test signal number 3

For AIS conformance testing purposes, the equipment shall have facilities to generate a 511-bit pseudo random sequence as specified in clause 2.1 of Recommendation ITU-T O.153 [4] shall be used as the data within an AIS message frame with header, start flag, end flag and CRC. NRZI is not applied to the pseudo random sequence or CRC. The RF should be ramped up and down on either end of the AIS message frame.

6.5.4 Unmodulated carrier

Additionally for conformance testing, the equipment shall have facilities for generating an unmodulated carrier.

6.6 AIS Reference timing signal

For the timing tests in clauses 9.4, 9.5 and 9.6 access to the edge trigger timing signal corresponding to T_0 in figure 5 of clause 9.4 is required. Refer to annex F for more information.

6.7 Standard test signals for DSC receiver testing

The standard test signal for testing a DSC decoder shall be a phase-modulated signal at VHF channel 70 with modulation index = 2. The modulating signal shall have a nominal frequency of 1 700 Hz and a frequency shift of ± 400 Hz with a modulation rate of 1 200 baud.

Standard test signals shall ~~be consist of a series of at least ten identical test acknowledgements as specified in clause 6.9 of ETSI EN 301 025 [5].~~

~~Table A1-4.7 Determination of the DSC symbol error ratio~~

~~The method specified in clause 6.10 of ETSI EN 301 025 [5] of Recommendation ITU-R M.493-15 [2]. These shall be used. The manufacturer shall submit a second sample of the equipment modified concatenated in a continuous sequence or it shall be possible to allow examination of the received and decoded DSC information when testing to the requirements of clause 9 of the present document repeat them individually to make the measurements.~~

~~Ten concatenated test acknowledgement is equivalent to 250 symbols or 2 500 bits of data. A bit error rate of 10^{-2} is equivalent to at least eight out of ten test acknowledgements being received correctly.~~

6.8 Test conditions power sources and ambient temperatures

6.8.1 Normal and extreme test conditions

Conformity testing shall be carried out under normal test conditions (clause 6.9) and also where stated under extreme test conditions (clauses 6.10.1 and 6.10.2 applied simultaneously).

6.8.2 Test power sources

Where stated, the battery of the equipment shall be replaced by a test power source capable of producing normal ~~(clause 6.9.2)~~ and extreme test voltages as specified in clauses 6.409.2.1 and 6.10.2.2.

6.9 Normal test conditions

6.9.1 Normal temperature and humidity

Normal temperature and humidity conditions for tests shall be any convenient combination of temperature and humidity, within the following ranges:

- Temperature: +15 °C to +35 °C.
- Relative humidity: ~~20 % to~~ not exceeding 75 %.

6.9.2 Normal test voltage

The normal test voltage shall be determined in each case and shall be the voltage corresponding to the voltage that a fresh battery gives at normal temperature and humidity at a load equal to that of the equipment when activated.

6.10 Extreme test conditions

6.10.1 Extreme temperatures

For tests at extreme temperatures, measurements shall be made in accordance with the procedure specified in ~~clause 6.10.1.1 here in~~ at the lower and upper temperatures of -20 °C and +55 °C respectively ~~except when installed within other equipment subject to more stringent temperature requirements, in which case the more stringent requirements shall apply.~~

The equipment shall be switched off during the temperature stabilization period.

Before tests are carried out, the equipment shall have obtained thermal balance in the test chamber and have been activated for a period of 5 minutes.

The location of the equipment under test in the climatic chamber shall not substantially influence the power output or the power consumption of the equipment under test.

6.10.2 Extreme test voltages

6.10.2.1 Upper extreme test voltage

The upper extreme test voltage shall be determined in each case and shall be the voltage corresponding to the voltage that a fresh battery gives at the upper extreme temperature with a load equal to that of the equipment when activated. The equipment fitted with a primary battery shall be placed in a climatic chamber and heated to +55 °C allowing a stabilization period of 2 hours. The equipment shall then be activated. After 1 minute the battery voltage shall be measured. This voltage shall be taken as the upper extreme test voltage and shall be measured before disconnecting the battery.

6.10.2.2 Lower extreme test voltage

The lower extreme test voltage shall be determined in each case. The equipment fitted with a primary battery shall be placed in a climatic chamber and cooled to -20 °C allowing a stabilization period of 2 hours. The equipment shall then be activated for a period of 12 hours. After this period the battery voltage shall be measured. This voltage shall be taken as the lower extreme test voltage and shall be measured before disconnecting the battery.

6.11 Reference Bandwidths for emission measurements

The reference bandwidths used shall be as stated in ~~Tables 2~~ tables 1 and 3 below.

Table 2:1: Reference bandwidths to be used for the measurement of spurious emission

Frequency range	RBW
9 kHz to 150 kHz	1 kHz
150 kHz to 30 MHz	10 kHz
30 MHz to 1 GHz	100 kHz
1 GHz to 12,75 GHz	1 MHz

Table 3:2: Reference bandwidths to be used close to the wanted emission for equipment operating below 1 GHz

Frequency offset from carrier	RBW
250 % of the CSP to 100 kHz	1 kHz
100 kHz to 500 kHz	10 kHz

7 Environmental tests

7.1 Introduction

The requirements of ~~this clause~~ below specified have the purpose to demonstrate that the equipment is capable of continuous operation under the conditions of various sea states, vibration, humidity and change of temperature likely to be experienced in the ocean or on a ship in which ~~it~~ the equipment is carried.

7.2 Procedure

Environmental tests shall be carried out before tests in respect of the other requirements in the present document are performed on the same EUT. Environmental tests may be carried out in any order but the test specified in clause 7.4 ~~3~~ 10 shall always be carried out last so as to detect any damage to EUT's water seals caused by the other environmental tests.

7.3 Performance check

The term performance check as used in the present document shall be that of activating the ~~locating beacon~~ EUT in test mode with GNSS data available, and checking ~~the procedure of clause 5.2 of ETSI EN 300 338-6 [1] is observed.~~ that:

- i) the procedure of clause 5.2.2 of ETSI EN 300 338-6 [1] is observed; and
- ii) checking the reception of Message 1 and Message 14 using an AIS receiver.

The performance check shall be carried out only under normal test conditions as detailed in clause 6.9.1 unless otherwise stated.

7.4 Drop test

7.4.1 Definition

The drop test immunity against the effects of dropping is the ability of the equipment to maintain the specified mechanical and electrical performance after being subjected to a series of drops onto a hard wooden test surface and into water.

7.4.2 Test conditions

During the test, the equipment shall be fitted with its batteries and antenna but it shall be switched off. The test shall be carried out under normal temperature and humidity conditions as detailed in clause 7.4 of ETSI EN 303 098 [2] with the exception 6.9.1.

The hard wooden test surface shall consist of a piece of solid hard wood 1 x 1 m, with a minimum thickness of 15 cm and a mass of at least 30 kilograms.

A container of calm sea water shall be used as the other surface.

The height of the lowest part of the equipment under test, relative to the test surface at the moment of release, shall be:

- i) for drops onto the wooden test surface: 1 m;
- ii) for drops into the water: 20 m.

Equipment shall be subjected to this test in the configuration as it is normally used in operational circumstances.

7.4.3 Method of measurement

Equipment that can be armed shall be armed before testing (see clause 4.2).

For drop into water the test shall consist of a single drop test, and the test shall be performed on the EUT complete with any detachable shock absorbers, which are normally part of it (e.g. a personal floatation device).

For drops on the wooden surface the test shall consist of six drops, once on each face, and the test shall be performed on the EUT alone excluding detachable shock absorbers.

7.4.4 Required results

After the drops have been completed the equipment shall be inspected visually for signs of damage. Inspection for mechanical damage, both internal and external, shall be carried out. Any damage shall not impair the operation of the equipment. In particular, parts like knobs, switches and the antenna shall operate in the normal manner. For devices without a water immersion sensor the act of dropping shall not cause the equipment to activate. For devices with a water immersion sensor the act of dropping onto the wooden test surface shall not cause the equipment to activate, whereas drops into water shall always cause the equipment to activate.

The requirement for the performance check referred to shall be replaced with the performance check of the present document (clause 7.3) shall also be met.

7.5 Temperature tests

7.5.1 Definition

The immunity against the effects of temperature tests are is the ability of the equipment to maintain the specified mechanical and electrical performance after the following tests have been carried out.

The maximum rate of raising or reducing the temperature of the chamber in which the equipment is being tested shall be 1 °C/minute.

7.5.2 Dry heat test

7.5.2.1 Method of measurement

The equipment shall be placed in a chamber at normal temperature. The temperature shall then be raised to, and maintained between +67 °C and +73 °C for a period of at least 10 hours. The chamber shall be cooled to between +52 °C and +58 °C. The cooling of the chamber shall be completed within 30 minutes.

At the end of this period the EUT shall be subjected to the performance check.

The temperature shall then be maintained between +52 °C and +58 °C for a period of at least 10 hours.

At the end of this period the EUT shall again be subjected to the performance check. The temperature of the chamber shall be maintained at between +52 °C and +58 °C during the whole of the performance check periods.

At the end of the test, the EUT shall be returned to normal environmental conditions or to those at the start of the next test.

7.5.2.2 Requirements

The test shall not cause the equipment to activate or operate spuriously.

The requirement for the performance check (clause 7.5 of ETSI EN 303 098 [2]3) shall also be met.

7.5.3 Damp heat test

7.5.3.1 Method of measurement

The EUT shall be placed in a chamber at normal room temperature and relative humidity. The temperature shall then be raised to between +38 °C and +42 °C, and the relative humidity raised to between 90 % and 96 % over a period of 3 hours. These conditions shall be maintained for a period of at least 10 hours.

The EUT shall be switched on 30 minutes later and shall be kept operational for at least 2 hours during which period the EUT shall be subjected to the performance check. The temperature and relative humidity of the chamber shall be maintained as specified during the whole test period.

At the end of the test period and with the exception EUT still in the chamber, the chamber shall be brought to room temperature in not less than 1 hour. At the end of the test the EUT shall be returned to normal environmental conditions or to those required at the start of the next test.

7.5.3.2 Required results

The test shall not cause the equipment to activate or operate spuriously.

The requirement for the performance check (clause 7.3) shall also be met.

7.5.4 Low temperature test

7.5.4.1 Method of measurement

The equipment shall be placed in a chamber at normal room temperature. Then the temperature shall be reduced to and maintained at between -33 °C and -27 °C for a period of at least 10 hours. The chamber shall be warmed to between -23 °C and -17 °C. The warming of the chamber shall be completed within 30 minutes.

At the end of this period the EUT shall be subjected to the performance check.

The temperature shall then be maintained at between -23 °C and -17 °C for a period of at least 10 hours.

At the end of this period the EUT shall again be subjected to the performance check. The temperature of the chamber shall be maintained at between -23 °C and -17 °C during the whole of the performance check periods.

7.5.4.2 Required results

The test shall not cause the equipment to activate or operate spuriously.

The requirement for the performance check (clause 7.3) shall also be met.

7.5.5 Low temperature battery endurance test

7.5.5.1 Method of measurement

Using a fresh battery that the performance check referred to shall be replaced with the performance check of the present document has been partially discharged to remove the amount of energy that would have been used by the equipment operating normally for 1 year (excluding activations).

The equipment shall then be placed in a chamber at normal room temperature. Then the temperature shall be reduced to and maintained at between -23 °C and -17 °C for a period of at least 10 hours. The equipment shall be activated and the transmissions of the equipment during the test shall be verified for a period of 12 hours. The temperature of the chamber shall be maintained as specified above for the whole of the period of 12 hours. At the end of the test the EUT shall be returned to normal environmental conditions.

7.5.5.2 Required results

The equipment shall remain activated and transmitting for a minimum of 12 hours.

Following the test the requirement for the performance check (clause 7.3) shall also be met.

7.6 Vibration test

7.6.1 Definition

The immunity against the effects of vibration test is the ability of the equipment to maintain the specified mechanical and electrical performance when the following test is carried out.

7.6.2 Method of measurement

Equipment that can be armed shall be armed before testing (see clause 7.6 of ETSI EN 303 098 [2]4.2).

The equipment, complete with the exception that the any detachable shock absorbers that are normally part of it (e.g. a personal floatation device), shall be clamped to the vibration table by its normal means of support and in its normal attitude.

Provisions may be made to reduce or nullify any adverse effect on the equipment performance which may be caused by the presence of any electro-magnetic fields from the vibration table.

Taking at least 15 minutes to cover each octave of frequency, the equipment shall be subjected to sinusoidal vertical vibration at all frequencies between:

- 2 Hz or 5 Hz up to 13,2 Hz with an excursion of a peak amplitude between 0,9 mm and 1,1 mm;
- 13,2 Hz up to 100 Hz with a constant maximum acceleration of 7 m/s².

A resonance search shall be carried out during the vibration test. If any resonance of the EUT has Q greater than 5 measured relative to the base of the vibration table, the EUT shall be subjected to a vibration endurance test at each resonant frequency at the vibration level specified in the test with a duration of 2 hours. If no resonance with Q greater than 5 occurs the endurance test shall be carried out at one single observed frequency. If no resonance occurs the endurance test shall be carried out at a frequency of 30 Hz.

The test shall be repeated with vibration after rotating the EUT by 90°.

A performance check ~~referred to shall be replaced with~~ shall be carried out at least once during each endurance test period and once before the end of each endurance test period.

The vibration table is described in clause 4 of IEC EN 60068-2-64 [i,11].

7.6.3 Required results

The test shall not cause the equipment to activate or operate spuriously.

The requirement for the performance check ~~of the present document~~(clause 7.3) shall also be met. No damage or mechanical deterioration shall be visible to the naked eye. The EUT if tested with a vibration absorber (e.g. a personal floatation device) shall not become detached.

7.7 Saltwater spray test

7.7.1 Definition

The immunity against the effects of saltwater spray is the ability of the equipment to maintain the specified mechanical and electrical performance both during and after the following test has been carried out. This tests the immunity of the equipment to:

- a) False alarms for equipment fitted with an immersion sensor.
- b) Insulation faults.
- ~~c)~~ Corrosion test of metals.
- d) Clogging or binding of moving parts as a result of salt deposits.

7.7.2 Method of measurement

7.7.2.1 The corrosion test is specified spraying apparatus

A chamber with a volume not larger than 0,3 m³ and fitted with apparatus capable of spraying in the form of fine mist shall be used. The chamber, spraying equipment and spray nozzle atomizers shall be made of materials that are non-reactive to the salt solution.

For apparatus using compressed air as a propellant means shall be provided to humidify and warm the compressed air as required to meet the operating conditions. To avoid clogging the atomizers with salt deposits, the compressed air should be humidified to a relative humidity of at least 85 % at the point of release from the nozzle.

A sodium chloride (NaCl) solution shall be used comprising 5 parts sodium chloride by weight to 95 parts distilled or de-mineralized water by weight. The sodium chloride (NaCl) used for the solution shall contain, when dry, not more than 0.1 % sodium iodide and not more than 0.3 % of total impurities.

The pH value of the solution shall be between 6,5 and 7,2 at a temperature of between 33 °C and 37 °C. The pH value shall be maintained within this range during conditioning. For this purpose, diluted hydrochloric acid or sodium hydroxide may be used to adjust the pH value, provided that the concentration of NaCl remains within the prescribed limits. The pH value shall be measured when preparing each new batch of solution.

The spraying apparatus shall incorporate a filter or similar means to prevent clogging of the atomizers. A suitable filter fabricated of noncorrosive materials, fitted in the solution supply line and immersed in the salt solution reservoir is illustrated in figure 14-2 of Eurocae ED14G [i.10].

7.7.2.2 Preparation of EUT

Before testing the EUT shall be thoroughly cleaned of oil, dirt and grease as necessary until the outer surfaces are free from water beading. The cleaning solvents used shall not be corrosive or cause damage to EUT.

Equipment that can be armed shall be armed before testing (see clause 7.7 of ETSI EN 303 098 [2] 4.2).

7.7.2.3 Test cycles

Step 1 The EUT shall be sprayed simultaneously on all its external surfaces with the salt solution for a period of 24 hours in the spraying chamber maintained at a temperature of between 33 °C and 37 °C.

Step 2 Following this the EUT shall be removed from the spraying chamber and left to dry at normal temperature and humidity (clause 6.9.1) for 24 hours. Care should be taken not to disturb the test item or adjust any mechanical features during the drying period.

Step 3 Replace the EUT in the spraying chamber and repeat step 1 and then remove the EUT and repeat step 2 one more time.

7.7.2.4 Conclusion of testing

At the end of testing the EUT shall be disarmed (clause 4.2).

The equipment shall then be rinsed and examined visually.

7.7.3 Required results

The test shall not cause the equipment to operate spuriously.

For equipment fitted with an immersion sensor, the test shall not cause the equipment to activate.

There shall be no deterioration or corrosion of the metal parts, finishes, material, or component parts visible to the naked eye.

All mechanical actions (including the action of disarming the equipment) shall be checked to ensure that they operate freely and are not binding or clogged with salt deposits.

7.8 Thermal shock test

7.8.1 Definition

The immunity against the effects of thermal shock test is the ability of the equipment to maintain the specified mechanical and electrical performance after the following test has been carried out.

7.8.2 Method of measurement

The equipment shall be operational but not armed before testing (see clause 7.8 of ETSI EN 303 098 [2] with the exception that 4.2).

The equipment shall be placed in a chamber at a temperature between +67 °C and +73 °C for 1 hour. It shall then be removed from the chamber and immersed in water at between +22 °C and +28 °C within 30 seconds to a depth of 10 cm, measured from the highest point of the equipment to the surface of the water, for a period of 1 hour.

On completion of the test the equipment enclosure shall be dried and then opened to inspect for water ingress.

7.8.3 Required results

The test shall not cause the equipment to activate or operate spuriously.

The requirement for the performance check referred to shall be replaced with the performance check of the present document (clause 7.3) shall also be met. No damage shall be visible to the naked eye and the equipment shall not show any sign of external damage or penetration of water.

7.9 Buoyancy test

7.9.1 Definition

Buoyancy, expressed as a percentage, is its buoyant force divided by its gravity force.

7.9.2 Method of measurement

The equipment shall be operational but disarmed before testing (see clause 4.2).

For Category 1 equipment the equipment shall be submerged in calm fresh water.

For Category 2 equipment the equipment and its buoyancy device shall be submerged in calm fresh water.

The buoyant force shall be measured when the equipment is totally submerged in fresh water. The buoyant force shall be then divided by the measured gravity force.

7.9.3 Required results and limit

The test is specified in clause 7.9 of ETSI EN 303 098 [2]. shall not cause the equipment to activate or operate spuriously.

The value of buoyancy shall be at least 5 %.

7.10 ~~Compass safe distance~~ Protection of the transmitter

7.10.1 Definition

When operating, the equipment transmitter shall not be damaged due to antenna mismatching and shall remain water-tight.

7.10.2 Method of measurement

This test shall be carried out on the same sample of the equipment used for testing to, and after all the preceding tests in clause 7 have been carried out.

The compass safe distance test is specified in clause 7.10 of ETSI EN 303 098 [2].

7.11 ~~Solar radiation test~~

~~The solar radiation~~ With the equipment activated and transmitting, the equipment shall be completely immersed in water to a depth of 5 m for a period of 5 minutes. For equipment fitted with an extendible antenna, the test shall be carried out with the antenna fully extended, and repeated with the antenna fully retracted under normal test conditions.

Saline solution of normal sea saltness (see saltwater spray test is specified in clause 7.11 of ETSI EN 303 098 [2].7) shall be used.

~~7.12 Oil resistance test~~

~~The oil resistance test is specified in clause 7.12 of ETSI EN 303 098 [2].~~

~~7.13 Protection of the transmitter~~

On completion of the test the equipment enclosure shall be dried and then opened to inspect for water ingress.

7.10.3 Required results

The test shall not cause the equipment to deactivate or operate spuriously.

The protection equipment shall not show any sign of external damage or penetration of the transmitter test is specified in clause 7.13 of ETSI EN 303 098 [2] with the exception that water, and the performance check referred to shall be replaced with requirements of the performance check of the present document (clause 7.3) shall also be met.

8 Tests on the DSC transmitter

8.1 DSC Frequency error

8.1.1 Definition

~~The definition in clause 8.1.1 of ETSI EN 301 025 [5] applies.~~

The frequency error is the difference between the measured carrier frequency and its nominal value.

8.1.2 Method of measurement

~~The method of measurement described in clause 8.1.2 of ETSI EN 301 025 [5] shall be applied, with the exception that the channel used for the test is channel 70.~~

The carrier frequency shall be measured in the absence of modulation, with the transmitter connected to an artificial antenna (see clause 6.3) and set to transmit on channel 70 (156,525 MHz). The EUT shall transmit continuously and the carrier frequency measured.

Measurements shall be made under normal test conditions (see clause 6.9) and under extreme test conditions (see clause 6.10).

8.1.3 Limit

~~The absolute frequency error shall be within \pm not exceed 1,5 kHz.~~

8.2 DSC Conducted Powerpower variation

8.2.01 Purpose

The purpose of this test is to verify that the output power from the locating beacon EUT is within limits at extreme operating temperatures; and to use these measurements to verify that the radiated power at extreme of temperature is within limits

Note that the conducted power delivered to an artificial antenna is likely to be greater than the measured ERP (see clause 8.3) where a salty man support (see clause 6.8 of ETSI TS 103 052 [3]) is used due to RF absorption of the support.

8.2.42 Definition

Conducted power is the average or mean power delivered to the artificial antenna (see clause 6.3) in the absence of modulation. The conducted power variation is the variation in conducted power over the extreme temperature range.

8.2.23 Method of measurement under normal test conditions

The transmitter shall be connected to an artificial antenna (see clause 6.3) and set to transmit on channel 70. The EUT shall transmit continuously and the average or mean power delivered to this artificial antenna shall be measured under normal conditions (see clause 6.9), and at the extremes of temperature (see clause 6.10.1).

The mean power under normal conditions P_{Norm} shall be measured in dBm (this value shall be recorded as it is used in the test method of clause 8.4).

The mean power under extreme conditions P_{-20} and P_{+55} shall be measured in dBm.

~~The differences between the normal and extreme conditions shall be determined:~~

$$P_{\text{diff1}} = P_{\text{Norm}} - P_{-20} \quad \text{and} \quad P_{\text{diff2}} = P_{\text{Norm}} - P_{+55}$$

8.2.34 Limit

~~The~~In both case the absolute difference between the in conducted power under extreme conditions and the conducted power under normal conditions: $P_{\text{Norm}} - P_{-20}$ and $P_{\text{Norm}} - P_{+55}$, shall be less than ± 3 dB.

8.3 Maximum Effective Radiated Power (ERP)

8.3.1 Definition

The Effective Radiated Power (ERP) is the power radiated in the direction of the maximum field strength under the specified conditions of measurements.

8.3.2 Method of measurement

The measurement is made under normal conditions (see clause 6.9) on channel 70 and then repeated for AIS1 and then AIS2.

~~On~~The EUT shall be fitted with the supplied antenna.

~~In a test site selected from semi-anechoic chamber as specified in clause 5.2.1 of ETSI TS 103 052 [3], the equipment shall be placed on a support in the standard position as described in clause 6.8 of ETSI TS 103 052 [6] for annex C. For category 1 equipment intended to be worn on a person, or that the test support described in annex C clause 6.8 of ETSI EN 303 098 TS 103 052 [2] for equipment not intended to be worn on a person used instead. The transmitter shall be switched on to transmit continuously without modulation subject to the limitations of clause 6.3.2.~~

The receiver shall be tuned to the transmitter carrier frequency. The test antenna shall be orientated for vertical polarization. The test antenna shall be raised or lowered through the specified range of heights from 1 to 4 metres until a maximum signal level is detected on the measuring receiver.

The transmitter shall be rotated through 360° around a vertical axis in order to find the direction of the maximum signal.

The maximum signal level detected by the measuring receiver (peak hold) shall be noted as P_{EUT} .

The transmitter shall be replaced by a substitution antenna as defined in clause 5.3.2 of ETSI TS 103 052 [3].

The substitution antenna shall be connected to a calibrated signal generator.

The frequency of the calibrated signal generator shall be adjusted to the transmit carrier frequency.

~~The input attenuator setting of the measuring receiver shall be adjusted in order to increase the sensitivity of the measuring receiver, if necessary.~~

The test antenna shall be raised or lowered ~~through the specified range of heights~~ from 1 to 4 metres to ensure that the maximum signal is received.

~~The input maximum signal to the substitution antenna shall be adjusted to the level that produces a level detected by the measuring receiver that is equal to the level (peak hold) shall be noted to that detected from the equipment under test corrected for the change in input attenuator setting of the measuring receiver as P_{REF} .~~

The maximum ERP is equal to the measured power of EUT, minus the power supplied by the signal generator, increased by minus the gain of the substitution antenna and corrected for the change in the attenuator (Gain) referenced to a dipole:

$$ERP = P_{EUT} - (P_{REF} + Gain)$$

8.3.3 Limits

The ERP shall be at least 100 mW, and not more than ~~500~~600 mW.

8.4 DSC Adjacent channel power

8.4.1 Definition

~~The definition in clause 8.7.1 of ETSI EN 301 025 [5] applies.~~

The adjacent channel power is that part of the total power output of a transmitter under defined conditions of modulation which falls within a specified passband centred on the nominal frequency of either of the adjacent channels. This power is the sum of the mean power produced by the modulation hum and noise of the transmitter.

8.4.2 Method of measurement

The method of adjacent channel power shall be measured with a power measuring receiver which conforms to annex B (referred to in annex B as the "receiver") according to the following procedure:

- a) The transmitter shall be operated at the carrier power determined in clause 8.2 (P_{Norm}) under normal test conditions. The output of the transmitter shall be linked to the input of the "receiver" by a connecting device such that the impedance presented to the transmitter is 50 Ω and the level at the "receiver" input is not overloaded.
- b) With the transmitter unmodulated, the tuning of the "receiver" shall be adjusted so that a maximum response is obtained. This is the 0 dB response point. The "receiver" attenuator setting and the reading of the meter shall be recorded.

The measurement shall be made with the transmitter modulated with the test modulation specified in clause 6.4.3.

- c) The tuning of the "receiver" shall be adjusted above and below the carrier so that the "receiver" -6 dB response nearest to the transmitter carrier frequency is located at a displacement from the nominal carrier frequency of 17 kHz.
- d) The transmitter shall be modulated with a pseudo-random B-Y sequence as described in clause 8.7.2 of ETSI EN 301 025 [5] shall be applied~~6.4.3.~~
- e) The "receiver" variable attenuator shall be adjusted to obtain the same meter reading as in step b) or a known relation to it.
- f) The ratio of adjacent channel power to carrier power is the difference between the attenuator settings in dB in steps b) and e).

g) The measurement shall be repeated with the "receiver" tuned to the other side of the carrier.

8.4.3 Limit

Adjacent channel power shall be 70 dB below the carrier power of the transmitter without any need to be below the spurious emission limit of 0,25 μ W.

8.5 DSC Transmitter transient frequency behaviour

8.5.1 Definition

~~The definition in clause 8.10.1 of ETSI EN 301 025 [5] applies.~~

8.5.2 Method of measurement

~~The~~The transient frequency behaviour of the transmitter is the variation in time of the transmitter frequency difference from the nominal frequency of the transmitter when the RF output power is switched on and off.

~~t_{on}~~: according to the method of measurement described in clause 8.10.2 of ETSI EN 301 025 [5] 5.2 the switch-on instant t_{on} of a transmitter is defined by the condition when the output power, measured at the antenna terminal, exceeds 0,1 % of the nominal power;

~~t₁~~: period of time starting at t_{on} and finishing according to table 3;

~~t₂~~: period of time starting at the end of t₁ and finishing according to table 3;

~~t_{off}~~: switch-off instant defined by the condition when the nominal power falls below 0,1 % of the nominal power;

~~t₃~~: period of time that finishing at t_{off} and starting according to table 3.

Table 3: Time periods

<u>t₁ (ms)</u>	<u>5,0</u>
<u>t₂ (ms)</u>	<u>20,0</u>
<u>t₃ (ms)</u>	<u>5,0</u>

8.5.2 Method of measurement

A spectrum analyser capable of making a direct measurement of frequency versus time shall be applied used provided that it is able to display frequency deviations of at least 100 kHz/100 ms and can be triggered by the rising and falling edges of the transmit power envelope.

i) The resolution bandwidth shall be set to 100 kHz.

ii) The video bandwidth shall be set to 100 kHz.

iii) The sweep time shall be set to 100 ms.

The EUT antenna port (clause 6.3.2) shall be connected to the spectrum analyser input via a 50 ohm power attenuator (see figure 1).

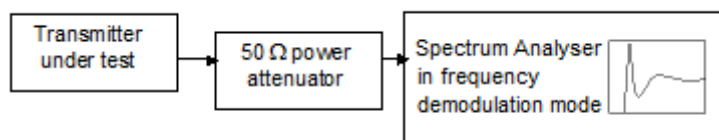

Figure 1: Measurement arrangement using a spectrum analyser

Where the above spectrum analyser is not available the following method shall be used (see figure 2).

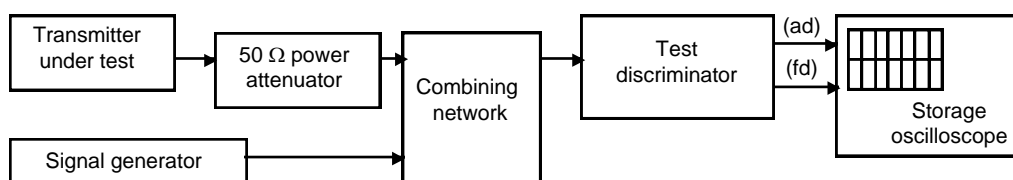

Figure 2: Measurement arrangement using a test discriminator

Two signals shall be connected to a linear FM discriminator via a 50 Ω combining network.

The transmitter shall be set to transmit on CH 70 and shall be connected to a 50 Ω power attenuator (see clause 6.3).

A test signal generator shall be set to transmit on 156 525 and shall be connected to the second input of the combining network.

The test signal shall be adjusted to the nominal frequency of the transmitter.

The test signal shall be modulated by a frequency of 1 kHz with a deviation of ± 25 kHz.

The test signal level shall be adjusted to correspond to 0,1 % of the power of the transmitter under test measured at the input of the test discriminator. This level shall be maintained throughout the measurement.

The amplitude difference (ad) and the frequency difference (fd) output of the test discriminator shall be connected to a storage oscilloscope.

The storage oscilloscope shall be set to display the channel corresponding to the (fd). The channel amplitude shall be set to display ± 25 kHz within 90 % of full-scale deflection.

The storage oscilloscope shall be set to a sweep rate of 10 ms/division and set so that the triggering occurs at one division from the left edge of the display.

The display shall show the 1 kHz test signal continuously.

The storage oscilloscope shall then be set to trigger on the channel corresponding to the amplitude difference (ad) input at a low input level, rising.

The transmitter shall then be switched on, without modulation, to produce the trigger pulse and a picture on the display.

The result of the change in the ratio of power between the test signal and the transmitter output will, due to the capture ratio of the test discriminator, produce two separate sides on the picture, one showing the 1 kHz test signal, the other the frequency difference of the transmitter versus time.

The moment when the 1 kHz test signal is completely suppressed defines t_{on} .

The periods of time t_1 and t_2 as defined in table 3 shall be used to define the appropriate template.

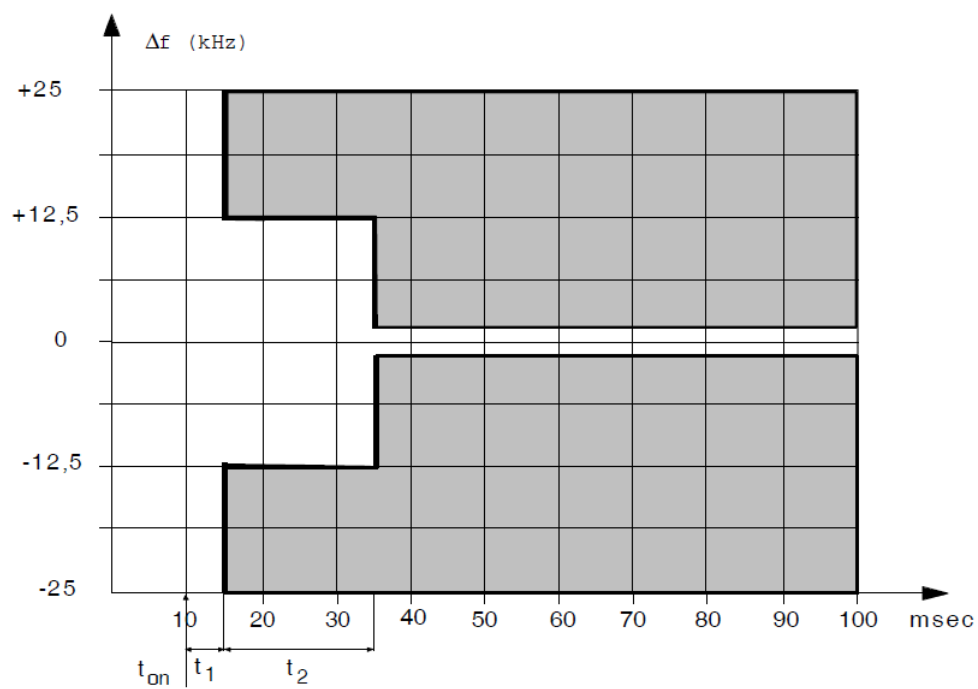
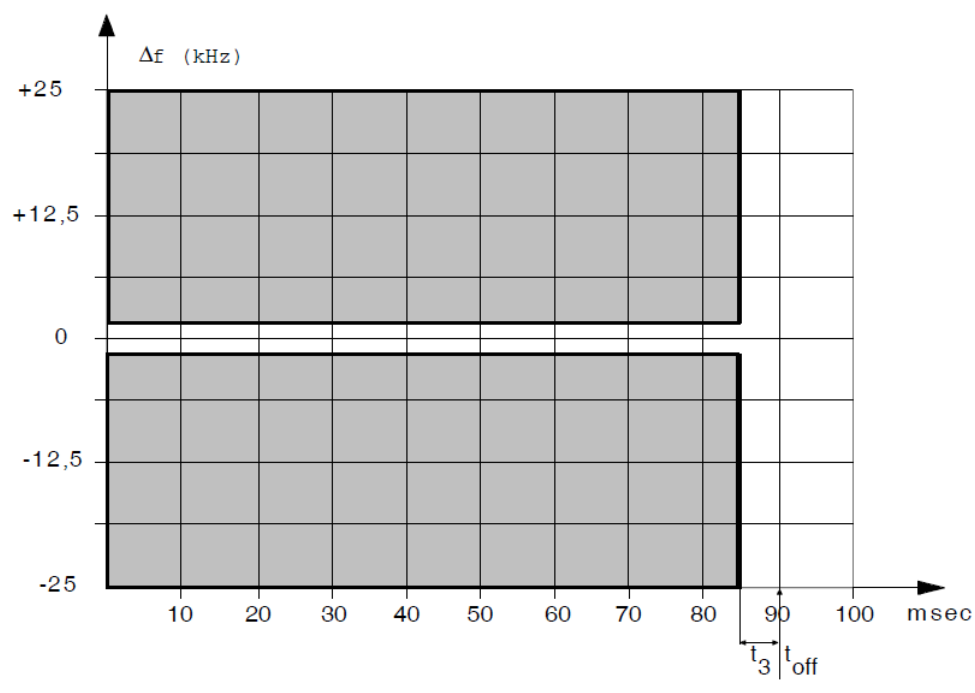
Switch on condition:**Switch off condition:****Figure 3: Frequency deviation masks for transmitter on and off**

The result shall be recorded as frequency difference versus time.

The transmitter shall remain switched on.

The storage oscilloscope shall be set to trigger on the channel corresponding to the amplitude difference (ad) input at a high input level, decaying and set so that the triggering occurs at 1 division from the right edge of the display.

The transmitter shall then be switched off.

The moment when the 1 kHz test signal starts to rise defines t_{off} .

The period of time t_3 as defined in table 3 shall be used to define the appropriate template.

The result shall be recorded as frequency difference versus time.

8.5.3 Limit

~~Transmitter transient behaviour~~ During the periods of time t_1 and t_3 the absolute value of the frequency difference shall not exceed 25 kHz.

The frequency difference after the end of t_2 shall be within the limit ~~shall be as defined~~ of the frequency error given in clause 8.1.

During the period of time t_2 the absolute value of the frequency difference shall not exceed 12,5 kHz.

Before the start of t_3 the frequency difference shall be within the limit of the frequency error given in clause 8.10.3 of ETSI EN 301 025 [5].1.

~~8.6 Residual modulation of the transmitter~~

8.6 Frequency error (demodulated DSC signal)

8.6.1 Definition

The definition in clause 8.11.1 of ETSI EN 301 025 [5] applies.

The frequency error for the B- and the Y-state is the difference between the measured frequency from the demodulator and the nominal values.

8.6.2 Method of measurement

The ~~method of measurement~~ transmitter shall be connected to the artificial antenna as specified in clause 6.3 and an FM demodulator. The transmitter shall be set to channel 70.

The transmitter shall be set to transmit a continuous B- and then Y- state as described in clause 8.11.2 of ETSI EN 301 025 [5] ~~shall be applied~~6.4.1.

The measurement shall be performed by measuring the demodulated output, for both the continuous B- and Y-state.

Measurements shall be made under normal test conditions (see clause 6.9) and under extreme test conditions (see clause 6.10).

8.6.3 Limit

The residual modulation shall not exceed 40 dB.

The measured frequency from the demodulator at any time for the B-state shall be between 2 090 Hz and 2 110 Hz and for the Y-state between 1 290 Hz and 1 310 Hz.

8.7 Frequency error (demodulated) Modulation index for DSC signal

8.7.1 Definition

The definition in clause 8.12.1 of ETSI EN 301 025 [5] applies.

This test measures the modulation index in the B and Y states.

8.7.2 Method of measurement

~~The method of measurement described in clause 8.12.2 of ETSI EN 301 025 [5] shall be applied.~~

The EUT shall be connected to a radio test set.

The EUT shall transmit on CH 70 with continuous B and then Y modulation as specified in clause (6.4.1).

The transmitter shall first be set to transmit continuous B state and the FM deviation measured.

The transmitter shall then be set to transmit continuous Y state and the FM deviation measured.

The modulation index is the FM deviation divided by the modulating frequency (B = 2,1 kHz and Y = 1,3 kHz).

8.7.3 Limit

~~Frequency error limit shall be as defined in clause 8.12.3 of ETSI EN 301 025 [5].~~

The modulation index shall be between 1,8 and 2,2 in both cases.

8.8 Modulation index ~~rate~~ for DSC

8.8.1 Definition

~~The definition in clause 8.13.1 of ETSI EN 301 025 [5] applies.~~

The modulation rate is the bit stream speed measured in bit/s.

8.8.2 Method of measurement

~~The method of measurement~~transmitter shall be set to transmit continuous dot pattern as described in clause 8.13.4.2.

The RF output terminal of the transmitter, suitably attenuated, shall be connected via a linear FM demodulator to a digital FSK demodulator capable of ETSI EN 301 025 [5] shall be applied demodulating the DSC signal. The output of the FSK demodulator shall be connected to a frequency counter.

The frequency of the demodulated digital pattern shall be measured.

8.8.3 Limit

~~Modulation index limit~~The frequency shall be as defined in clause 8.13.3 of ETSI EN 301 025 [5].

~~8.9 Modulation~~between 599,982 Hz and 600,018 Hz (this corresponds to a modulation rate for DSC of 1 200 baud).

8.9.1 Definition

~~The definition in clause 8.14.1 of ETSI EN 301 025 [5] applies.~~

8.9.2 Method of measurement

~~The method of measurement described in clause 8.14.2 of ETSI EN 301 025 [5] shall be applied.~~

8.9.3 Limit

~~Modulation rate limit shall be as defined in clause 8.14.3 of ETSI EN 301 025 [5].~~

8.10 Spurious emissions

8.409.1 Definition

Emission(s) on a frequency or frequencies which are outside the necessary bandwidth and the level of which may be reduced without affecting the corresponding transmission of information. Spurious emissions include harmonic emissions, parasitic emissions, intermodulation products, and frequency conversion products, but exclude out-of-band emissions.

8.409.2 Method of measurement

~~On~~In a test site selected from semi-anechoic chamber as specified in clause 5.2.1 of ETSI TS 103 052 [3], the equipment shall be placed on a support in the standard position as described in clause 6.8 of ETSI TS 103 052 [3] for equipment intended to be worn on a person, or that described in annex C for equipment not intended to be worn on a person.~~The transmitter shall be switched on to transmit continuously without modulation.~~

The method of measurement described in clause 8.3 shall be used to search for spurious emissions in the frequency band 30 MHz to 2 GHz, excluding the frequency band tested in clause 8.4.

The measuring receiver shall have a bandwidth as specified in ~~Table 2~~tables 1 and Table 32 of clause 6.11.

The measurement shall only be performed under normal test conditions, the ~~locating beacon~~EUT being rotated until the maximum emission is detected. The measurement is also made when the ~~locating beacon~~EUT has been activated but is not transmitting.

Firstly the transmitter shall be switched on to transmit continuously on channel 70 with random modulation as specified in clause 6.4.3.

Secondly the test shall be repeated with the transmitter switched on to transmit continuously on channel AIS1 with random modulation as specified in clause 6.5.3 using standard test signal number 3 without ramping up and down the RF power.

Thirdly the test shall be repeated with the transmitter switched on to transmit continuously on channel AIS2 with random modulation as specified in clause 6.5.3 using standard test signal number 3 without ramping up and down the RF power.

Finally the test shall be repeated with the transmitter switched off and the DSC receiver switched on (for example in the same test mode used for testing to the requirements of clause 10).

8.409.3 Limit

The power of any spurious emission component when transmitting shall not exceed 0,25 μ W.

The power of any spurious emission component when not transmitting shall not exceed 2 nW between 30 MHz and 1 GHz and 20 nW between 1 GHz and 2 GHz.

9 Tests on the ~~DSC receiver~~AIS transmitter

9.1 ~~Maximum usable sensitivity~~AIS Frequency error

9.1.1 Definition

~~The definition in clause 10.1.1 of ETSI EN 301 025 [5] applies.~~

The frequency error of the transmitter is the difference between the measured carrier frequency in the absence of modulation and its required frequencies AIS1 and AIS2.

9.1.2 Method of measurement

~~The method of measurement described in clause 10.1.2 of ETSI EN 301 025 [5] shall be applied, with the exception that the bit error ratio shall be determined as described in clause 6.7 of the present document.~~

The carrier frequency shall be measured with the equipment connected to an artificial antenna (see clause 6.3). The measurement shall be made using the test power source (see clause 6.8.2) under both normal and extreme test conditions. The carrier frequency shall be measured in the absence of modulation. The test shall be performed on AIS1 and AIS2.

9.1.3 Limit

The limit as defined in frequency error under normal conditions shall not exceed 500 Hz, and under extreme test conditions shall not exceed 1 kHz.

9.2 AIS Conducted power variation

9.2.1 Purpose

The purpose of this test is to verify that the output power from the EUT is within limits at extreme operating temperatures and to use these measurements to verify that the radiated power at the extremes of temperature is within limits.

Note that the conducted power delivered to an artificial antenna is likely to be greater than the measured ERP (see clause 4.18.3) where a salty man support (see clause 6.8 of ETSI EN 301 025 TS 103 052 [5] shall be applied) is used due to RF absorption of the support.

9.2 Co-channel rejection

9.2.1 Definition

~~The definition in clause 10.2.1 of ETSI EN 301 025 [5] applies.~~

Conducted power is the average or mean power delivered to the artificial antenna (see clause 6.3) in the absence of modulation. The conducted power variation is the variation in conducted power over the extreme temperature range.

9.2.2 Method of measurement

~~The method of measurement described in clause 10.2.2 of ETSI EN 301 025 [5] shall be applied, with the exception that the bit error ratio shall be determined as described in clause 6.7 of the present document.~~

9.2.3 The transmitter shall be connected to an artificial antenna (see clause 6.3) and set to transmit on AIS1. The EUT shall be set to transmit continuously. The average or mean power delivered to this artificial antenna shall be measured under normal conditions (see clause 6.9), and at the extremes of temperature (see clause 6.10.1).

A measurement for frequency AIS1 shall be made and repeated with the EUT set to transmit on AIS2.

The mean power under normal conditions P_{Norm} shall be measured in dBm (this value shall be recorded as it is used in the test method of clauses 9.3 and 9.4).

The mean power under extreme conditions P_{-20} and P_{+55} shall be measured in dBm.

9.2.4 Limit

In both case the absolute difference in conducted power: $P_{Norm} - P_{-20}$ and $P_{Norm} - P_{+55}$ shall be less than 3 dB.

9.3 AIS Transmitter spectrum mask

9.3.1 Definition

The limit as defined in clause 10.2.3 of ETSI EN 301 025 [5] shall be applied.

~~9.3 Adjacent channel selectivity~~

~~9.3.1 Definition~~

~~The definition in clause 10.3.1 of ETSI EN 301 025 [5] applies.~~

The transmitter spectrum mask defines the limits within the range $f_c - 75$ kHz and $f_c + 75$ kHz for the peak power of all modulated signals including all side bands associated with the carrier.

9.3.2 Method of measurement

The ~~method~~ transmitter shall be connected to an artificial antenna (see clause 6.3) with a means of measuring the power delivered to the load. The equipment shall be operated from the test power source (clause 6.8.2). Standard test signal number 3 (see clause 6.5.3) shall be used to modulate the transmitter in repeated packets.

The measurement described in clause 10.3.2 of ETSI EN 301 025 [5] shall be shall be made under normal test conditions (see clause 6.9).

To determine the reference peak power and measure the emissions in the adjacent channels, the emission is suitably applied, with the exception to the input of a spectrum analyser with the following preferred settings:

- Resolution bandwidth: 1 kHz;
- Video bandwidth: 3 kHz;
- Scan bandwidth: 150 kHz;
- Centre frequency: Carrier frequency AIS1 and AIS2;
- Detector type: Peak hold.

The EUT shall continuously repeat the transmission of packets for one minute to ensure that the emission profile is fully developed. The reference carrier power P_{Norm} measured in clause 9.2.3 shall be used to normalize the emission profile so that the reference carrier power is set to 0 dBc. The spurious emissions limit of clause 8.9.3 (0.25 μ W or -36 dBm) is also normalized to determine the spurious power limit P_s using the following equation:

$$P_s = -36 - P_{Norm} \text{ (dBc)}.$$

Where P_{Norm} is the value recorded in clause 9.2.3.

The result is compared to the mask given in figure 4.

A measurement for frequency AIS1 shall be made and repeated for AIS2.

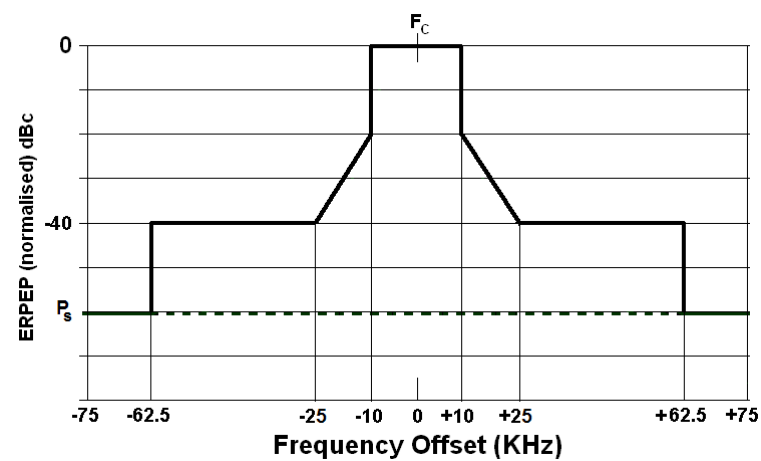

Figure 4: Transmitter spectrum mask

9.3.3 Limit

The normalized emission profile shall not exceed the mask of figure 4.

9.4 AIS Transmitter transient behaviour (output power)

9.4.1 Definition

The transient behaviour (output power) of the transmitter is determined as described in clause 6.7 by the time-dependency of the transmitter power when the transmitter output power is switched on and off. Within the scope of the present document, only the transmit power as a function of time is tested as shown in figure 5 and defined in table 4 where:

~~9.3.3 Limit~~

~~The limit as defined in clause 10.3.3 of ETSI EN 301 025 [5] shall be applied.~~

~~9.4 Spurious response and blocking immunity~~

~~9.4.1 Definition~~

~~The definition in clause 10.4.1 of ETSI EN 301 025 [5] applies.~~

~~9.4.2 Method of measurement~~

~~The method of measurement described in clause 10.4.2 of ETSI EN 301 025 [5] shall be applied, with transmitter delay time (TA - T0) is the exception that time between the bit error ratio shall be determined as described in clause 6.7 start of the present document.~~

~~9.4.3 Limit~~

~~The limit as defined in clause 10.4.3 of ETSI EN 301 025 [5] shall be applied.~~

9.5 Intermodulation response

9.5.1 Definition

The definition in clause 10.5.1 of ETSI EN 301 025 [5] applies.

9.5.2 Method of measurement

- The method of measurement described in clause 10.5.2 of ETSI EN 301 025 [5] shall be applied, with slot and the exception that moment when the bit error ratio shall be determined as described in clause 6.7 transmit power may exceed -50 dB of the present document steady-state power (P_{SS});
- transmitter attack time ($T_B - T_A$) is the time between the transmit power exceeding -50 dBc and the moment when the transmit power maintains a level within +1,5 dB - 1 dB from P_{SS} ;
- transmitter release time ($T_F - T_E$) is the time between the end flag being transmitted and the moment when the transmitter output power has reduced to a level 50 dB below P_{SS} and remains below this level thereafter;
- transmission duration ($T_F - T_A$) is the time from when power exceeds -50 dBc to when the power returns to and stays below -50 dBc.

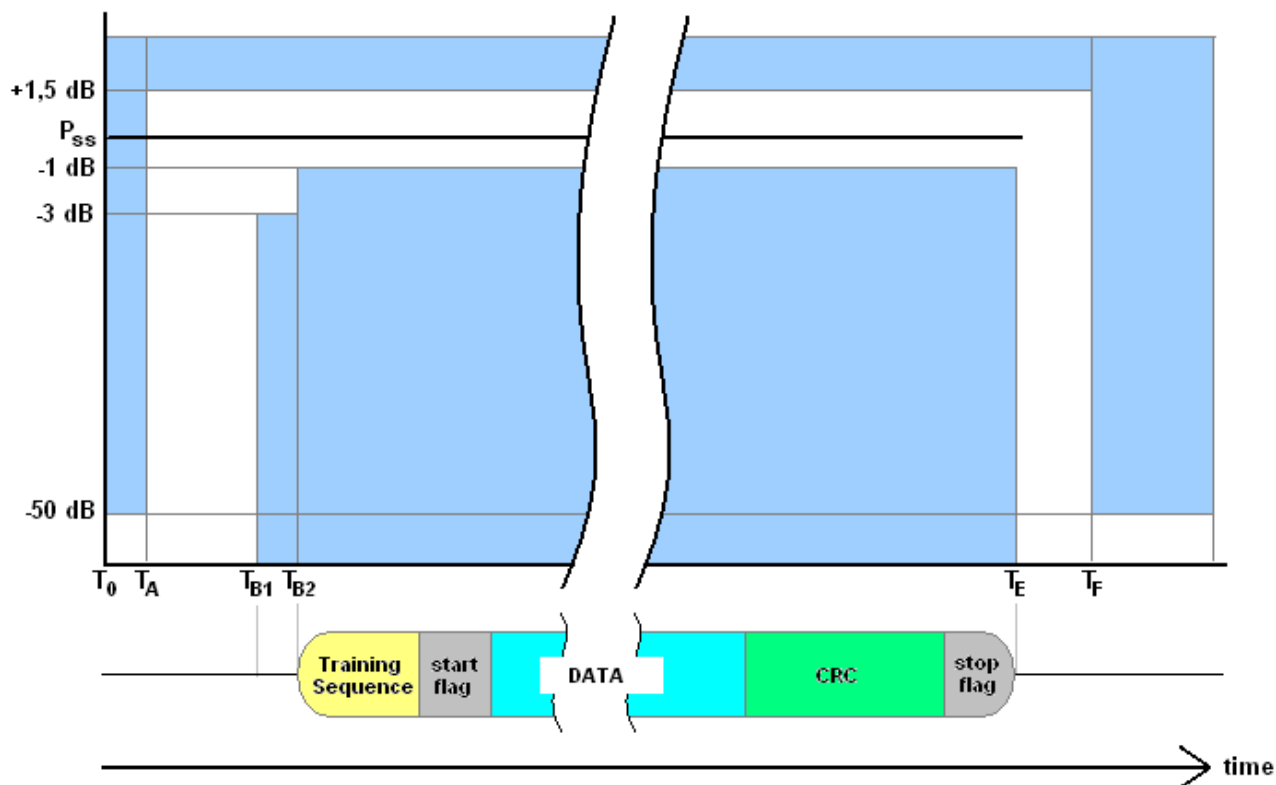

Figure 5: Power versus time mask

Table 4: Definitions of timings and limits

Reference	Bit Periods	Time (ms)	Definition
T_0	0	0	Start of transmission slot. Power shall NOT exceed -50 dB of P_{SS} before T_0
T_A	0 to 6	0 to 0,625	T_A = Point at which power exceeds -50 dB of P_{SS}
T_B	T_{B1}	6	Power shall be within +1,5 or -3 dB of P_{SS}
	T_{B2}	8	Power shall be within +1,5 or -1 dB of P_{SS}
T_E (includes 1 stuffing bit)	233	24,271	Power shall remain within +1,5 or -1 dB of P_{SS} during the period T_{B2} to TE (see note)
T_F (includes 1 stuffing bit)	241	25,104	Power shall be \leq -50 dB of P_{SS} and stay below this
T_G	256	26,667	Start of next transmission time period
At no point shall the transmitted power exceed P_{Norm} (as measured in clause 9.2.3) during the transmitted sequence			
NOTE: There shall be no modulation of the RF after the termination of transmission (TE) until the power has reached zero and the next slot begins (TG).			

9.4.2 Method of measurement

9.5.3 Limit

The limit as defined in clause 10.5.3 of ETSI EN 301 025 [5] shall be applied.

9.6 Dynamic range

9.6.1 Definition

The definition in clause 10.6.1 of ETSI EN 301 025 [5] applies.

9.6.2 Method of measurement

The method of measurement described in clause 10.6.2 of ETSI EN 301 025 [5] shall be applied, with the exception that the bit error ratio shall be determined as described in clause 6.7 of the present document.

9.6.3 Limit

The limit as defined in clause 10.6.3 of ETSI EN 301 025 [5] shall be applied.

10 Interoperability Testing

10.1 Active mode tests

10.1.1 Listen Before Talk (LBT)

10.1.1.1 Method of measurement

The measurement is made under normal conditions (see clause 6.9) for frequency AIS1 and repeated for AIS2.

The standard test signal transmitter shall be connected to an artificial antenna (see clause 6.6)3). The measurement shall be applied carried out by transmitting test signal number 1.

A spectrum analyser shall be used to make the input measurements with the following preferred settings:

- Resolution bandwidth: 1 MHz
- Video bandwidth: 1 MHz
- Scan bandwidth: zero span
- Centre frequency: Carrier frequency as measured in clause 9.1
- Detector type: sample detector [single sweep mode]

The spectrum analyser shall be synchronized to the nominal start time of the slot (T_0) using the edge trigger timing signal described in clause 6.6.

9.4.3 Limit

The transmitter power shall remain within the mask shown in figure 5 and associated timings and limits given in table 4.

9.5 AIS Transmitter Transient Behaviour (frequency deviation)

9.5.1 Definition

The transient behaviour (frequency deviation) of the transmitter is determined by the time-dependency of the frequency deviation during the transmission of an AIS message.

A test to verify that the training sequence starts with a 0 and is a 0101 pattern of 24 bits. The peak frequency deviation is derived from the baseband signal to verify modulation accuracy.

9.5.2 Method of measurement

The measurement is made under normal and extreme conditions (see clauses 6.9 and 6.10) for frequency AIS1 and repeated for AIS2.

The transmitter shall be connected to an artificial antenna (see clause 6.3) comprising a power attenuator and RF signal analyser (figure 6).

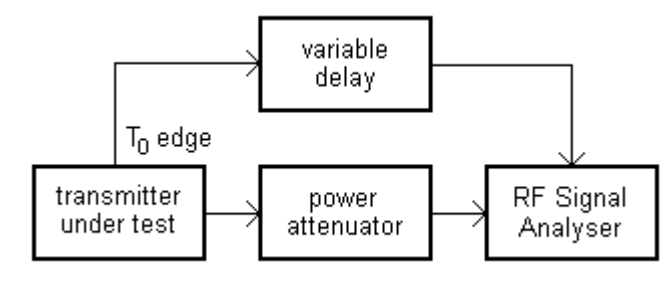

Figure 6: Measurement arrangement for modulation accuracy

The measuring device shall be synchronized to the nominal start time of the first preamble bit (T_B), using the edge trigger timing signal described in clause 6.6. Using test signal 2 the delay from the T_0 timing edge provided by EUT is adjusted until the centre position of the first data bit (bit 0) is determined as the trigger point T_B . Holding these settings test signal 2 is replaced with test signal 1 to confirm that T_B has been correctly determined.

The transmitter shall be modulated with test signal number 2.

The deviation from the carrier frequency shall be measured as a function of time.

The transmitter shall be modulated with test signal number 1.

The deviation from the carrier frequency shall be measured as a function of time.

9.5.3 Limit

In each case the observed training sequence shall begin with a '0'.

The peak frequency deviation error at a various points within the data frame shall comply with table 5. These limits apply to both the positive and negative modulation peaks. Bit 0 is defined as the first bit of the training sequence.

Table 5: Peak frequency deviation error versus time

Measurement period from centre to centre of each bit	Test signal 1		Test signal 2	
	Normal	Extreme	Normal	Extreme
Bit 0 to bit 1	< 1 000 Hz			
Bit 2 to bit 3	480 Hz			
Bit 4 to bit 31	240 Hz	480 Hz	240 Hz	480 Hz
Bit 32 to bit 199	175 Hz	350 Hz	240 Hz	480 Hz

9.6 AIS Synchronization accuracy

9.6.1 Definition

The synchronization accuracy defines the allowable time deviation including additive jitter in the transmission of an AIS message from ideal SOTDMA timing. The synchronization accuracy test verifies that the EUT transmission will be properly synchronized once UTC lock is acquired.

This test requires analysis of the transmissions of the EUT in active mode.

9.6.2 Method of measurement

The EUT shall be programmed with valid UTC parameters as described in the user documentation or shall be preconditioned so as to have downloaded valid UTC parameters before the start of the test.

The measurement is made under normal and extreme conditions (see clauses 6.9 and 6.10) for frequency AIS1 and repeated for AIS2.

The transmitter shall be connected to an artificial antenna (see clause 6.3). The EUT's GNSS receiver shall be connected to a GNSS simulator simulating more than 3 satellites and that additionally provides a UTC output and a 1 pps reference output with an accuracy of 1 μ s or better (figure 7). The T_0 edge signal is the edge trigger timing signal described in clause 6.6.

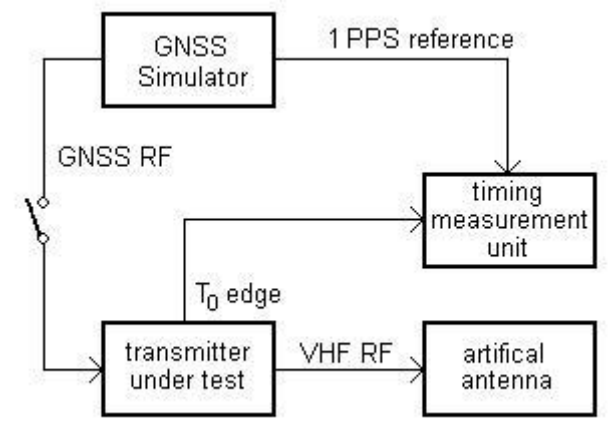

Figure 7: Measurement arrangement for synchronization accuracy

Activate the EUT in active mode with GNSS signal enabled. After 15 minutes record AIS transmissions for 40 minutes.

Whenever a transmission is recorded the associated absolute difference in timing between the EUT generated T_0 edge and the GNSS simulator generated 1 pps reference shall be recorded. The EUT may pick any one of 75 slots in any two second period. The legitimate timings for both even and odd seconds are given in table 6.

Table 6: Legitimate T0 Timings (μ s) in any second

<u>Even</u>	<u>Odd</u>	<u>Even</u>	<u>Odd</u>	<u>Even</u>	<u>Odd</u>	<u>Even</u>	<u>Odd</u>
<u>26 667</u>	<u>13 333</u>	<u>293 333</u>	<u>280 000</u>	<u>560 000</u>	<u>546 667</u>	<u>826 667</u>	<u>813 333</u>
<u>53 333</u>	<u>40 000</u>	<u>320 000</u>	<u>306 667</u>	<u>586 667</u>	<u>573 333</u>	<u>853 333</u>	<u>840 000</u>
<u>80 000</u>	<u>66 667</u>	<u>346 667</u>	<u>333 333</u>	<u>613 333</u>	<u>600 000</u>	<u>880 000</u>	<u>866 667</u>
<u>106 667</u>	<u>93 333</u>	<u>373 333</u>	<u>360 000</u>	<u>640 000</u>	<u>626 667</u>	<u>906 667</u>	<u>893 333</u>
<u>133 333</u>	<u>120 000</u>	<u>400 000</u>	<u>386 667</u>	<u>666 667</u>	<u>653 333</u>	<u>933 333</u>	<u>920 000</u>
<u>160 000</u>	<u>146 667</u>	<u>426 667</u>	<u>413 333</u>	<u>693 333</u>	<u>680 000</u>	<u>960 000</u>	<u>946 667</u>
<u>186 667</u>	<u>173 333</u>	<u>453 333</u>	<u>440 000</u>	<u>720 000</u>	<u>706 667</u>	<u>986 667</u>	<u>973 333</u>
<u>213 333</u>	<u>200 000</u>	<u>480 000</u>	<u>466 667</u>	<u>746 667</u>	<u>733 333</u>	-	-
<u>240 000</u>	<u>226 667</u>	<u>506 667</u>	<u>493 333</u>	<u>773 333</u>	<u>760 000</u>	-	-
<u>266 667</u>	<u>253 333</u>	<u>533 333</u>	<u>520 000</u>	<u>800 000</u>	<u>786 667</u>	-	-

The UTC output from the simulator is used by the timing measurement unit to determine when even or odd slot timing measurements apply. The absolute difference between a legitimate slot start and the measured T_0 is the synchronization error.

9.6.3 Limit

Verify that all transmissions have a synchronization error (including additive jitter) of less than 312 μ s.

10 Tests on the DSC receiver

10.1 DSC Maximum usable sensitivity

10.1.1 Definition

The maximum usable sensitivity of the receiver is the minimum level of +6 dB μ V the signal applied at the nominal frequency of the receiver at which the packet error ratio of the decoder does not exceed a specified value.

10.1.2 Method of measurement

DSC standard test signals (see clause 6.7) containing Test acknowledgements shall be applied to the receiver input (see clause 6.3.3). The input level shall be 0 dB μ V under normal test conditions (clause 6.9) and +6 dB μ V under extreme test conditions (clause 6.10).

The measurement shall be repeated under normal test conditions at the nominal carrier frequency offset by plus and minus 1.5 kHz.

10.1.3 Limit

At least eight out of ten test acknowledgement messages shall be indicated as received by the EUT (see clause 4.3.2.2 iv), each time the test is repeated.

10.2 DSC Co-channel rejection

10.2.1 Definition

The co-channel rejection is a measure of the capability of the receiver to receive a wanted modulated signal without exceeding a given degradation due to the presence of an unwanted modulated signal, both signals being at the nominal frequency of the receiver.

10.2.2 Method of measurement

The two input signals shall be connected to the receiver input terminal via a combining network (see clause 6.3.3). The wanted signal shall be the DSC standard test signal (see clause 6.7) containing Test acknowledgements. The unwanted signal shall be a 156 525 MHz carrier frequency modulated as defined in Recommendation ITU-R M.493-15 [2] annex 1, clause 1.3.2 with a continuous pseudo-random pattern comprising a 511-bit pseudo-random B-Y sequence as specified in clause 2.1 of Recommendation ITU-T O.153 [4]. Both input signals shall be at the nominal frequency of the receiver under test and the measurement shall be repeated for displacements of the unwanted signal frequency, offset by plus and minus 3 kHz.

The input level of the wanted signal shall be +3 dB μ V.

The input level of the unwanted signal shall be -5 dB μ V.

10.2.3 Limit

At least eight out of ten test acknowledgement messages shall be indicated as received by the EUT (see clause 4.3.2.2 iv)), each time the test is repeated.

10.3 DSC Adjacent channel selectivity

10.3.1 Definition

The adjacent channel selectivity is a measure of the capability of the receiver to receive a wanted modulated signal without exceeding a given degradation due to the presence of an unwanted modulated signal which differs in frequency from the wanted signal by 25 kHz.

10.3.2 Method of measurement

The two input signals shall be connected to the receiver input terminal via a combining network (see clause 6.3.3).

The wanted signal shall be the DSC standard test signal (see clause 6.7) containing Test acknowledgements.

The unwanted signal shall be modulated to 400 Hz with a deviation of ± 3 kHz. The unwanted signal shall be tuned to the centre frequency of the upper adjacent channel. The measurement shall be repeated with the unwanted signal tuned to the centre frequency of the lower adjacent channel.

The measurement shall be made under normal test conditions (see clause 6.9) and under extreme test conditions (see clause 6.10).

The input level of the wanted signal shall be +3 dB μ V under normal test conditions and +9 dB μ V under extreme test conditions.

The input level of the unwanted signal shall be 60 dB μ V under normal test conditions and 50 dB μ V under extreme test conditions.

10.3.3 Limit

At least eight out of ten test acknowledgement messages shall be indicated as received by the EUT (see clause 4.3.2.2 iv)), each time the test is repeated.

10.4 DSC Spurious response

10.4.1 Definition

The spurious response rejection is a measure of the capability of the receiver to receive a wanted modulated signal without exceeding a given degradation due to the presence of an unwanted modulated signal at any other frequency, at which a response is obtained.

10.4.2 Spurious response frequency calculations

To determine the frequencies at which spurious responses can occur the following calculations shall be made.

The frequencies at which spurious responses can occur is determined from the harmonics of the frequency of the Local Oscillator signal (fLO) applied to the first mixer of the receiver plus or minus the first intermediate frequency (fI1) of the receiver.

Hence, the frequencies of these spurious responses are:

$$N fLO \pm fI1$$

where N is an integer.

The measurement of the first image response of the receiver (where N = 1) shall initially be made to verify the calculation of spurious response frequencies.

The frequency of the receiver is 156 525 MHz, which is the only solution to the above equation that is not a spurious response and therefore shall not be tested.

Spurious response frequencies shall be calculated up to a maximum frequency of 2.7 GHz.

The manufacturer shall state the frequency of the Local Oscillator signal (fLO) applied to the 1st mixer of the receiver and the first intermediate frequency fI1.

10.4.3 Method of measurement

The two input signals shall be connected to the receiver input terminal via a combining network (see clause 6.3.3).

The wanted signal shall be the DSC standard test signal (see clause 6.7) containing Test acknowledgements.

The unwanted signal shall be unmodulated. The test shall be repeated for all frequencies calculated in clause 10.4.2 up to 2.7 GHz.

The input level of the wanted signal shall be +3 dBμV.

The input level of the unwanted signal shall be 60 dBμV.

10.4.4 Limit

At least eight out of ten test acknowledgement messages shall be indicated as received by the EUT (see clause 4.3.2.2 iv)), each time the test is repeated.

10.5 DSC Intermodulation response

10.5.1 Definition

The intermodulation response is a measure of the capability of the receiver to receive a wanted modulated signal without exceeding a given degradation due to the presence of two or more unwanted signals with a specific frequency relationship to the wanted signal frequency.

10.5.2 Method of measurement

The three input signals shall be connected to the receiver input terminal via a combining network (see clause 6.3.3).

The wanted signal represented by signal generator A shall be at the nominal frequency of the receiver and shall be the DSC standard test signal (see clause 6.7) containing Test acknowledgements.

The unwanted signals shall be applied, both at the same level. The unwanted signal from signal generator B shall be unmodulated and adjusted to a frequency 50 kHz above (or below) the nominal frequency of the receiver. The second unwanted signal from signal generator C shall be modulated by 400 Hz with a deviation of ± 3 kHz and adjusted to a frequency 100 kHz above (or below) the nominal frequency of the receiver.

The input level of the wanted signal shall be +3 dB μ V.

The input level of the unwanted signals shall be 55 dB μ V.

10.5.3 Limit

At least eight out of ten test acknowledgement messages shall be indicated as received by the EUT (see clause 4.3.2.2 iv)), each time the test is repeated.

10.6 Blocking or desensitization

10.6.1 Definition

Blocking is a measure of the capability of the receiver to receive a wanted modulated signal without exceeding a given degradation due to the presence of an unwanted input signal at any frequencies other than those of the spurious responses or the adjacent channels.

10.6.2 Method of measurement

The two input signals shall be connected to the receiver input terminal via a combining network (see clause 6.3.3).

The wanted signal shall be the DSC standard test signal (see clause 6.7) containing Test acknowledgements.

For the blocking test the unwanted signal shall be unmodulated. The test shall be repeated for frequencies of -10 MHz, -5 MHz and -1 MHz and also +1 MHz, +5 MHz and +10 MHz relative to the nominal frequency of the wanted signal.

The input level of the wanted signal shall be +3 dB μ V.

The input level of the unwanted signal shall be 80 dB μ V.

10.6.3 Limit

At least eight out of ten test acknowledgement messages shall be indicated as received by the EUT (see clause 4.3.2.2 iv)), each time the test is repeated.

10.7 DSC Minimum dynamic range

10.7.1 Definition

The dynamic range of the equipment is the range from the lowest to the highest level of a radio frequency input signal at which the packet error ratio of the decoder does not exceed a specified value. The minimum dynamic range is a dynamic range set to a minimum value that the equipment has to operate over.

10.7.2 Method of measurement

A test signal in accordance with the DSC standard test signal (see clause 6.7) containing consecutive Test acknowledgements, shall be applied to the receiver input. The test shall be carried out with the level of the test signal set to 0 dB μ V and then the test shall be repeated with the level of the test signal set to 100 dB μ V.

10.7.3 Limit

At least eight out of ten test acknowledgement messages shall be indicated as received by the EUT (see clause 4.3.2.2 iv)), each time the test is repeated.

11 DSC Conformance Testing

11.1 Active mode tests

11.1.1 Listen Before Talk (LBT)

11.1.1.1 Method of measurement

The measurement is made under normal conditions (see clause 6.9).

The standard DSC test signal (see clause 6.7) shall be applied to the input of the EUT at a level of +6 dB μ V.

The EUT shall be activated in active mode and transmissions from the EUT shall be recorded.

1 minute after activating the EUT a break in the standard test signal of 47 ms shall be applied.

2 minutes after activating the EUT the ~~applying the~~ standard test signal shall be broken off altogether.

~~10~~11.1.1.2 Required Results

The following is required:

- a) No message is transmitted within the first 2 minutes following activation.
- b) The first message transmission starts within 100 ms of breaking off the standard test signal.

~~10~~11.1.2 First and second individual closed loop distress relay transmissions

~~10~~11.1.2.1 Applicability

This test only applies to devices of type DSC-MOB-C (Closed loop devices).

11.1.2.2 Method of measurement

The method is based on TD_DSC_VHF_RDA_0003MOB_0006 as described in ETSI TS 101 570-26 [i.5] and ETSI TS 101 570-3 [i.6] [5].

The measurement is made under normal conditions (see clause 6.9).

The EUT shall be activated in active mode with GNSS signals present and transmissions from the EUT shall be recorded for 10 minutes.

~~10 seconds after transmission of each individual distress relay~~ After receiving all the required messages from the EUT a DSC Distress Alert relay acknowledgment message shall be applied to the input of the EUT. The DSC message shall be formatted in accordance with ~~Table~~ table A1-4.4, row 1 of Recommendation ITU-R M.493-44 [5] [2] and shall be addressed with the self ID of the EUT.

4011.1.2.23 Required Results

The following is required:

- ~~a~~a) The EUT displays the visual indication specified in clause 4.3.2.1 i).
- b) The EUT transmits an individual distress relay within a period 10 to 30 seconds following activation and the message contains the following fields:
 - ~~a~~b.i) The format specifier is set to 120.
 - ~~a~~b.ii) The destination address MMSI is the Own vessel MMSI (clause ~~4.5E.7~~) configured in the EUT.
 - ~~a~~b.iii) The category is set to 112.
 - ~~a~~b.iv) The Self ID is as configured in the EUT.
 - ~~a~~b.v) The first telecommand is set to 112.
 - ~~a~~b.vi) The Distress MMSI is the self ID as configured in the EUT.
 - ~~a~~b.vii) The nature of distress is set to 110.
 - ~~a~~b.viii) The position = 9999999999.
 - ~~a~~b.ix) The time = 8888.
 - ~~a~~b.x) The subsequent communications field is set to 126.
- ~~b)~~ ~~On receipt of the applied first DSC Distress Alert relay acknowledgment message the EUT~~ The EUT's visual indicator state ~~as~~ changes to the visual indicator specified in clause 4.3.3 is unchanged.
- ~~c)~~ ~~The EUT transmits another~~ 2.1 ii) and the next individual distress relay within 5 minutes following activation, and the message that the EUT transmits contains the following fields:
 - c.i) The format specifier is set to 120.
 - c.ii) The destination address MMSI is the Own vessel MMSI (clause ~~4.5E.7~~) configured in the EUT.
 - c.iii) The category is set to 112.
 - c.iv) The Self ID is as configured in the EUT.
 - c.v) The first telecommand is set to 112.
 - c.vi) The Distress MMSI is the self ID as configured in the EUT.
 - c.vii) The nature of distress is set to 110.
 - c.viii) The position = position of EUT.
 - c.ix) The time = UTC time.
 - c.x) The subsequent communications field is set to 126.
- d) The distress alert message received in (b) above was transmitted no more than 5,1 minutes after activation.
- ~~e)~~ ~~On receipt of the applied second DSC Distress Alert relay acknowledgment message the EUT makes no further transmissions, disarms and displays the correct visual indicator as specified in clause 4.3.3 (vii)~~ 2.1 iii).
- ~~f)~~ The EUT shall then be disarmed locally as part of the test.
- ~~g)~~ EUT displays the visual indication specified in clause 4.3.2.1 iv).

11.1.3 First open loop distress ~~transmission~~transmissions

~~40~~11.1.3.1 Applicability

This test only applies to devices of type DSC-MOB-O (Open loop devices).

11.1.3.2 Method of measurement

The method is based on TD_DSC_VHF_RDA_0002MOB_0003 as described in ETSI TS 101 570-26 [i.5] and ETSI TS 101 570-3 [i.6].5].

The measurement is made under normal conditions (see clause 6.9).

The EUT shall be activated in active mode with GNSS signals present and transmissions from the EUT shall be recorded for ~~30~~10 minutes.

After receiving all the required messages from the EUT a DSC Distress Alert acknowledgement message shall be applied to the input of the EUT. The DSC message shall be formatted in accordance with ~~Table~~table A1-4.2, row 1 of Recommendation ITU-R M.493-1415 [2] and shall be addressed with the self ID of the EUT.

~~40~~11.1.3.23 Required Results

The following is required:

~~The following is required:~~

- a) The EUT displays the visual indication specified in clause 4.3.2.1 i).
- ~~b) The EUT transmits an individual distress relay alert within a period 10 to 30 seconds following activation.~~
- ~~b) The EUT transmits one or more individual distress relay within 12 minutes following activation.~~
- ~~e) The EUT transmits a distress alert after 12 minutes following activation, and the message contains the following fields:~~
 - b.i) The format specifier is set to 112.
 - b.ii) The Self ID is as configured in the EUT.
 - b.iii) The nature of distress is set to 110.
 - b.iv) The distress coordinates = 9999999999.
 - b.v) The time = 8888.
 - b.vi) The subsequent communications field is set to 126.
- c) The EUT's visual indicator changes to the visual indicator specified in clause 4.3.2.1 ii) and the next distress alert message that the EUT transmits contains the following fields:
 - c.i) The format specifier is set to 112.
 - c.ii) The Self ID is as configured in the EUT.
 - c.iii) The nature of distress is set to 110.
 - c.iv) The distress coordinates = position of EUT.
 - c.v) The time = UTC time.
 - c.vi) The subsequent communications field is set to 126.
- d) The distress alert message received in (b) above was transmitted no more than 5.1 minutes after activation.

e) On receipt of the applied DSC Distress Alert acknowledgment message the EUT makes no further transmissions, ~~disarms~~ and displays the correct visual indicator as specified in clause 4.3.3 ~~(vii) 2.1 iii)~~.

~~40f) The EUT shall then be disarmed locally as part of the test.~~

g) EUT displays the visual indication specified in clause 4.3.2.1 iv).

11.1.4 Open loop distress repeat transmissions

~~40~~11.1.4.1 Applicability

This test applies to all devices.

NOTE: Devices of type DSC-MOB-O will start transmitting distress alerts immediately whereas devices of type DSC-MOB-C will start transmitting distress alerts after 10 minutes of activation.

11.1.4.2 Method of measurement

The method is based on TD_DSC_VHF_RDA_0002MOB_0003 as described in ETSI TS 101 570-26 [i.5] and ETSI TS 101 570 3 [i.6i.5].

The measurement is made under normal conditions (see clause 6.9).

The EUT shall be activated in active mode with GNSS signals present and shall record transmissions from the EUT for 20 minutes.

20 minutes following activation GNSS signals shall be inhibited and transmissions from the EUT shall be recorded for a further 20 minutes.

After receiving all the required messages from the EUT a DSC Distress Alert acknowledgement message shall be disarmed.

~~40.1~~applied to the input of the EUT. The DSC message shall be formatted in accordance with table A1-4.2, row 1 of Recommendation ITU-R M.493-15 [2] and shall be addressed with the self ID of the EUT.

11.1.4.3 Required Results

The following is required:

~~The following is required:~~

- a) The EUT of type DSC-MOB-C transmits an individual distress relay and The EUT of type DSC-MOB-O transmits a distress alert within a period 10 to 30 seconds following activation.
- b) The EUT transmits ~~two~~one or more individual distress relay additional messages of the same type within 10 minutes following activation.
- c) The EUT transmits a distress alert no sooner than 12 minutes following after activation the EUT transmits a distress alert, and the message contains the following fields:
 - c.i) The format specifier is set to 112.
 - c.ii) The Self ID is as configured in the EUT.
 - c.iii) The nature of distress is set to 110.
 - c.iv) The distress coordinates = position of EUT.
 - c.v) The time = UTC time.
 - c.vi) The subsequent communications field is set to 126.
- d) The EUT continues to transmit distress alert messages with the same field settings as (c) above for the duration of the test.

10.2 ~~Test mode tests with GNSS signals present~~

10.2.1 ~~Listen Before Talk (LBT)~~

10.2.1.1 ~~Method~~ On receipt of measurement

~~The measurement is made under normal conditions (see clause 6.9).~~

~~The standard test signal (see clause 6.6) shall be the applied to the input of DSC Distress Alert acknowledgment message the EUT at a level of +6 dBuV.~~

~~The EUT shall be activated in test mode and shall record makes no further transmissions from the EUT.~~

~~3 minutes after activating the EUT a break in the standard test signal of 190 ms shall be applied.~~

~~4 minutes after activating the EUT the standard test signal shall be broken off altogether.~~

10.2.1.2 ~~Required Results~~

~~The following is required:~~

- ~~a) No message is transmitted within 4 minutes following activation.~~
- ~~b) The first message is transmitted within 5 minutes following activation but does not start before 200 ms after breaking off the standard test signal.~~

10.2.2 ~~Test message transmission (unacknowledged)~~

10.2.2.1 ~~Method of measurement~~

~~The method is based on TD_DSC_VHF_OC_0001, TD_DSC_VHF_OC_0002 as described in ETSI TS 101 570 2 [i.5] and ETSI TS 101 570 3 [i.6], TD_DSC_VHF_OC_0003 and TD_DSC_VHF_OC_0004 as described in ETSI TS 101 570 2 [i.5].~~

~~The measurement is made under normal conditions (see clause 6.9).~~

~~The EUT shall be activated in test mode with GNSS signals present and transmissions from the EUT shall be recorded for 10 minutes.~~

10.2.2.2 ~~Required Results~~

~~The following is required:~~

- ~~a) The EUT transmits a test message within 5 minutes after activation, and the message contains the following fields:

 - ~~a.i) The format specifier is set to 120.~~
 - ~~a.ii) The destination address MMSI is the Own vessel MMSI (see clause 4.5) configured in the EUT.~~
 - ~~a.iii) The category is set to 108.~~
 - ~~a.iv) The Self ID is as configured in the EUT.~~
 - ~~a.v) The first telecommand is set to 118.~~
 - ~~a.vi) The second telecommand is set to 118.~~
 - ~~a.vii) The frequency is set to 126.~~~~
- ~~b) The EUT indicates that the test is complete as with and displays the correct visual indicator as specified in clause 4.3.3 (v2.1 iii).~~

ef) The EUT makes no further transmissions.

10.2.3 ~~Test message transmission (acknowledged)~~

10.2.3.1 ~~Method of measurement~~

~~The method is based on TD_DSC_VHF_OC_0001, TD_DSC_VHF_OC_0002 as described in ETSI TS 101 570 2 [i.5] and ETSI TS 101 570 3 [i.6], TD_DSC_VHF_OC_0003 and TD_DSC_VHF_OC_0004 as described in ETSI TS 101 570 2 [i.5].~~

~~The measurement is made under normal conditions (see clause 6.9).~~

~~The EUT shall then be activated in disarmed locally as part of the test mode with GNSS signals present and transmissions from the EUT shall be recorded for 10 minutes.~~

~~On receipt of a test message from the EUT a DSC test acknowledgement message shall be applied. The DSC message shall be formatted in accordance with Table A1 4.7, row 7 of Recommendation ITU R M.493 14 [3] and shall be addressed with the self ID of the EUT.~~

10.2.3.2 ~~Required Results~~

~~The following is required:~~

- a) ~~The EUT transmits a test message within 5 minutes after activation, and the message contains the following fields:~~
 - a.i) ~~The format specifier is set to 120.~~
 - a.ii) ~~The destination address MMSI is the Own vessel MMSI (see clause 4.5) configured in the EUT.~~
 - a.iii) ~~The category is set to 108.~~
 - a.iv) ~~The Self ID is as configured in the EUT.~~
 - a.v) ~~The first telecommand is set to 118.~~
 - a.vi) ~~The second telecommand is set to 118.~~
 - a.vii) ~~The frequency is set to 126.~~
- b) ~~On receipt of the applied test acknowledgment message the EUT indicates that the test is complete with the correct g) EUT displays the visual indicator as indication specified in clause 4.3.3 (vii 2.1 iv).~~
- e) ~~On receipt of the applied test acknowledgment message the EUT makes no further transmissions.~~

10.3 Test 12 AIS VDL Link layer tests

12.1 Active mode tests with no GNSS signals present

10.3.1 12.1 Method of measurement

~~The Activate the EUT shall be activated in test active mode and record transmissions for 640 minutes with no. Inhibit GNSS data available and shall record transmissions for a further 20 minutes.~~

~~10.3.2 Record the activation time of the EUT.~~

~~For all transmitted messages record:~~

- ~~• transmission time (UTC);~~

- transmission slot;
- in-slot timing;
- transmission channel;
- message content.

The records will be evaluated in the following test items.

12.1.2 Initialization period - Required results

The following is required:

- a) ~~a)~~ The first message is transmitted within 60 seconds after activation.
- b) The first message with a valid position is transmitted within 5 minutes.

12.1.3 Message content of Message 1 - Required results

For position reports transmitted after 5 minutes and before 40 minutes the following is required:

- a) Message ID = 1.
- b) Repeat indicator = 0.
- c) Self ID as configured in the EUT ~~deactivates after 5 minutes.~~ (see clause 4.4).
- d) ~~b)~~ Navigational status = 14.
- e) Rate of turn = default.
- f) SOG = actual SOG from GNSS receiver.
- g) Position accuracy = according to the RAIM result if provided, otherwise 0.
- h) Position = actual position from internal GNSS receiver.
- i) Position is updated at least once per minute, for each burst.
- j) COG = actual COG from internal GNSS receiver.
- k) True heading = default.
- l) Time stamp = actual UTC second (0...59).
- m) Verify correct visual indication according to clause 4.3.2.1 i).

12.1.4 Message content of Message 14 - Required results

The following is required:

- a) Message ID = 14.
- b) Repeat indicator = 0.
- c) Self ID as configured in the EUT ~~indicates~~ (see clause 4.4).
- d) Text = "MOB ACTIVE".

12.1.5 Transmission schedule for Message 1 - Required results

For position reports transmitted after 15 minutes and before 40 minutes the following applies:

- a) Verify that the test EUT has been abandoned with the correct visual indicator as specified in clause 4.3.3 (not operated in sync mode 0 (UTC direct)).
- b) The EUT transmits one burst of messages once per minute.
- c) The duration of a burst is 14 seconds.
- d) A burst consists of 8 messages.
- e) The transmissions in a burst are alternating between AIS1 and AIS2.
- f) Consecutive messages are 75 slots apart.
- g) The same set of slots is used in each burst for 8 minutes.
- h) A new set of slots is selected after 8 minutes.
- i) The first slot of the new set of slots is within the interval of 1 minute \pm 6 seconds from the first slot of the previous set of slots, that is the increment is selected in the range 2 025 slots to 2 475 slots.

12.1.6 Communication state of Message 1 - Required results

For position reports transmitted after 5 minutes and before 40 minutes the following applies:

- a) The SOTDMA communication state as defined for message 1 is used.
- b) The sync state = 0.
- c) The time-out starts with 7 for all messages of the first burst after a change in slots.
- d) The time-out value is decremented by 1 for each frame.
- e) The time-out value is reset to 7 after time-out = 0.
- f) The sub message for time-out 3,5,7 = number of received stations (0).
- g) The sub message for time-out 2,4,6 = slot number.
- h) The sub message for time-out 1 = UTC hour and minute.
- i) The sub message for time-out 0 = slot offset to the transmission slot in the next frame.

12.1.7 Transmission schedule of Message 14 - Required results

The following is required:

- a) Message 14 is transmitted every 4 minutes.
- b) The transmissions of Message 14 are alternating between AIS1 and AIS2.
- c) Message 14 is transmitted in a Message 1 slot, replacing the Message 1, on the channel for which the Message 1 was scheduled.
- d) Message 14 did not replace a Message 1 with a time-out value = 0.

12.1.8 Transmission with lost GNSS - Required results

For position reports transmitted after 45 minutes the following applies:

- a) The EUT continues transmission.
- b) The same transmission schedule is used as with GNSS data available.
- c) Communication State Sync state = 3.
- d) SOG = last valid SOG.

- e) Position accuracy = low.
- f) Position = last valid position.
- g) COG = last valid COG.
- h) Time stamp = 63.
- i) RAIM-flag = 0.
- j) Verify correct visual indication according to clause 4.3.2.1 i).

13 Testing for compliance with technical requirements

4413.1 Environmental conditions for testing

These Tests defined in the present document shall be carried out at representative points within the boundary limits of the operational environmental profile defined by its intended use, which, as a minimum, shall be that specified in the test conditions contained in the present document.

Where technical performance varies subject to environmental conditions, tests shall be carried out under a sufficient variety of environmental conditions as specified in the present document to give confidence of compliance for the affected technical requirements.

General conditions of measurement shall be as described clause 6.

~~11.2~~ Interpretation of the measurement results

~~The interpretation of the results recorded in a test report for the measurements described in the present document shall be as follows:~~

- ~~• the measured value related to the corresponding limit will be used to decide whether an equipment meets the requirements of the present document;~~
- ~~• the value of the measurement uncertainty for the measurement of each parameter shall be included in the test report;~~
- ~~• the recorded value of the measurement uncertainty shall be, for each measurement, equal to or lower than the figures in Table 4.~~

~~For the test methods, according to the present document, the measurement uncertainty figures shall be calculated and shall correspond to an expansion factor (coverage factor) $k = 1,96$ or $k = 2$ (which provide confidence levels of respectively 95 % and 95,45 % in the case where the distributions characterizing the actual measurement uncertainties are normal (Gaussian)). Principles for the calculation of measurement uncertainty are contained in ETSI TR 100 028 1 [i.2] and ETSI TR 100 028 2 [i.3], in particular in annex D of the ETSI TR 100 028 2 [i.3].~~

Table 4 is based on such expansion factors.

Table 4: Maximum measurement uncertainty

Parameter	Maximum uncertainty
Radio Frequency (RF)	$\pm 1 \times 10^{-2}$
Radiated emission of transmitter	± 6 dB
Conducted RF power variations using a test fixture	$\pm 0,75$ dB
Maximum frequency deviation:	
— within 300 Hz to 6 kHz of modulation frequency	± 5 %
— within 6 kHz to 25 kHz of modulation frequency	± 3 dB
Deviation limitation	± 5 %
Adjacent channel power	± 5 dB
Conducted spurious emission of transmitter	± 4 dB
Audio output power	$\pm 0,5$ dB
Amplitude characteristics of receiver limiter	$\pm 1,5$ dB
Sensitivity at 20 dB SINAD	± 3 dB
Conducted emission of receiver	± 3 dB
Two signal measurement	± 4 dB
Three signal measurement	± 3 dB
Transmitter transient time	± 20 %
Transmitter transient frequency	± 250 Hz
LBT timing accuracy	± 5 %

Annex A (informative): Relationship between the present document and the essential requirements of Directive 2014/53/EU

The present document has been prepared under the Commission's standardisation request C(2015) 5376 final [i.7i.2] to provide one voluntary means of conforming to the essential requirements of Directive 2014/53/EU on the harmonisation of the laws of the Member States relating to the making available on the market of radio equipment and repealing Directive 1999/5/EC [i.1].

Once the present document is cited in the Official Journal of the European Union under that Directive, compliance with the normative clauses of the present document given in Table A.1 confers, within the limits of the scope of the present document, a presumption of conformity with the corresponding essential requirements of that Directive and associated EFTA regulations.

Table A.1: Relationship between the present document and the essential requirements of Directive 2014/53/EU

Harmonised Standard ETSI EN 303 132					
Requirement				Requirement Conditionality	
No	Description	Essential requirements of Directive	Reference: Clause No(s) of the present document	U/C	Condition
1	DSC Frequency error	3.2	8.1	U	
2	Conducted Power		8.2	U	
32	Effective Radiated Power (ERP)	3.2	8.3	U	
43	DSC Adjacent channel power	3.2	8.4	U	
54	DSC Transmitter transient frequency behaviour	3.2	8.5	U	
6	Residual modulation of the transmitter		8.6	U	
75	Frequency error (demodulated DSC signal)	3.2	8.76	U	
86	Modulation index for DSC	3.2	8.87	U	
97	Modulation rate for DSC	3.2	8.98	U	
108	Spurious emissions	3.2	8.109	U	
9	AIS Frequency error	3.2	9.1	U	
10	AIS Transmitter spectrum mask	3.2	9.3	U	
11	AIS Transmitter transient behaviour (output power)	3.2	9.4	U	
12	AIS Transmitter transient behaviour (frequency deviation)	3.2	9.5	U	
13	AIS Synchronization accuracy	3.2	9.6	U	
14	DSC Maximum usable sensitivity	3.2	10.1	U	
15	DSC Co-channel rejection	93.2	10.2	U	
16	DSC Adjacent channel selectivity	3.2	10.3	U	

Harmonised Standard ETSI EN 303 132					
Requirement				Requirement Conditionality	
No	Description	<u>Essential requirements of Directive</u>	<u>Reference: Clause No(s) of the present document</u>	U/C	Condition
4417	DSC Spurious response and blocking immunity	3.2	910.4	U	
4518	DSC Intermodulation response	3.2	910.5	U	
19	Blocking or desensitization	3.2	10.6		
4620	Dynamic DSC Minimum dynamic range	9-63.2	10.7	U	
21	Requirements that can be visually inspected	3.3(g)	4	U	
22	Drop test	3.3(g)	7.4	U	
23	Temperature tests	3.3(g)	7.5	U	
24	Vibration test	3.3(g)	7.6	U	
25	Saltwater spray test	3.3(g)	7.7	U	
26	Thermal shock test	3.3(g)	7.8	U	
27	Buoyancy test	3.3(g)	7.9	U	
28	Protection of the transmitter	3.3(g)	7.10	U	
29	DSC Conducted power variation	3.3(g)	8.2	U	
30	AIS Conducted power variation	3.3(g)	9.2	U	
31	Listen Before Talk (LBT)	3.3(g)	11.1.1	U	
32	First closed loop distress transmissions	3.3(g)	11.1.2	C	See clause 11.1.2.1
33	First open loop distress transmissions	3.3(g)	11.1.3	C	See clause 11.1.3.1
34	Open loop distress repeat transmissions	3.3(g)	11.1.4	U	
35	AIS VDL Link layer tests	3.3(g)	12	U	

Key to columns:**Requirement:**

No A unique identifier for one row of the table which may be used to identify a requirement.

Description A textual reference to the requirement.

Essential requirements of Directive

_____ Identification of article(s) defining the requirement in the Directive.

Clause-Number(s) of the present document

_____ Identification of clause(s) defining the requirement in the present document unless another document is referenced explicitly.

Requirement Conditionality:

U/C	Indicates whether the requirement is unconditionally applicable (U) or is conditional upon the manufacturer's claimed functionality of the equipment (C).
Condition	Explains the conditions when the requirement is or is not applicable for a requirement which is classified "conditional".

Presumption of conformity stays valid only as long as a reference to the present document is maintained in the list published in the Official Journal of the European Union. Users of the present document should consult frequently the latest list published in the Official Journal of the European Union.

Other Union legislation may be applicable to the product(s) falling within the scope of the present document.

Annex B (normative): Measuring receiver for adjacent channel power measurement

B.1 Power measuring receiver specification

B.1.1 General

The power measuring receiver consists of a mixer, an IF filter, an oscillator, an amplifier, and an r.m.s. voltmeter calibrated in dB. The technical characteristics of the power measuring receiver are given below.

B.1.2 IF filter

The IF filter shall be within the limits of the following selectivity characteristics.

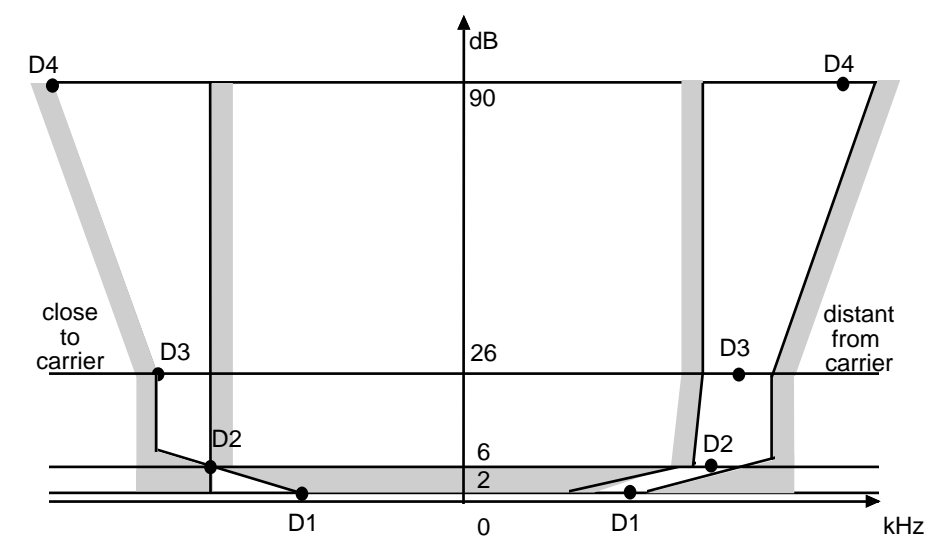

Figure B.1: IF filter characteristics

The selectivity characteristics shall keep the frequency separations shown in table B.1 from the nominal centre frequency of the adjacent channel.

Table B.1: Selectivity characteristic

Channel separation (kHz)	Frequency separation of filter curve from nominal centre frequency of adjacent channel (kHz)			
	D1	D2	D3	D4
12,5	3	4,25	5,5	9,5
25	5	8,0	9,25	13,25

The attenuation points shall not exceed following tolerances shown in table B.2.

Table B.2: Tolerance of attenuation points close to carrier

Channel separation (kHz)	Tolerance range (kHz)			
	D1	D2	D3	D4
12,5	+1,35	±0,1	-1,35	-5,35
25	+3,1	±0,1	-1,35	-5,35

Table B.3: Tolerance of attenuation points distant from the carrier

Channel separation (kHz)	Tolerance range (kHz)			
	D1	D2	D3	D4
12,5	$\pm 2,0$	$\pm 2,0$	$\pm 2,0$	$\pm 2,0$ $-6,0$
25	$\pm 3,5$	$\pm 3,5$	$\pm 3,5$	$\pm 3,5$ $-7,5$

The minimum attenuation of the filter outside the 90 dB attenuation points shall be equal to or greater than 90 dB.

B.1.3 Attenuation indicator

The attenuation indicator shall have a minimum range of 80 dB and a reading accuracy of 1 dB. With a view to future regulations an attenuation of 90 dB or more is recommended.

B.1.4 r.m.s. value indicator

The instrument shall accurately indicate non-sinusoidal signals in ratio of up to 10:1 between peak value and r.m.s. value.

B.1.5 Oscillator and amplifier

The oscillator and the amplifier shall be designed in such a way that the measurement of the adjacent channel power of a low-noise unmodulated transmitter, whose self-noise has a negligible influence on the measurement result, yields a measured value of less than -90 dB.

Annex C (normative): Additional Test Supports

C.1 Float-free support

The equipment shall be oriented in a manner in which it is designed to operate and placed on a circular ground plane capable of rotation through 360° in azimuth. As shown in figure C.1, the rotating ground plane B shall have a minimum diameter of $1,35\lambda$, (250 cm) and be made of highly conductive material (aluminium or copper). It shall be located at a reference height $X = 1,00 \pm 0,10$ m above the test site ground plane A. The equipment shall be mounted within the rotating ground plane B to a level such that its float line is aligned with the ground plane B and the antenna of the equipment orientated as normally deployed. For category 2 equipment this will include the personal flotation device. This ground plane shall be extended to fit closely around the equipment and to surround the below-waterline portion of the unit (e.g. using metal foil). An adapter plate which has a close fit to the equipment is recommended.

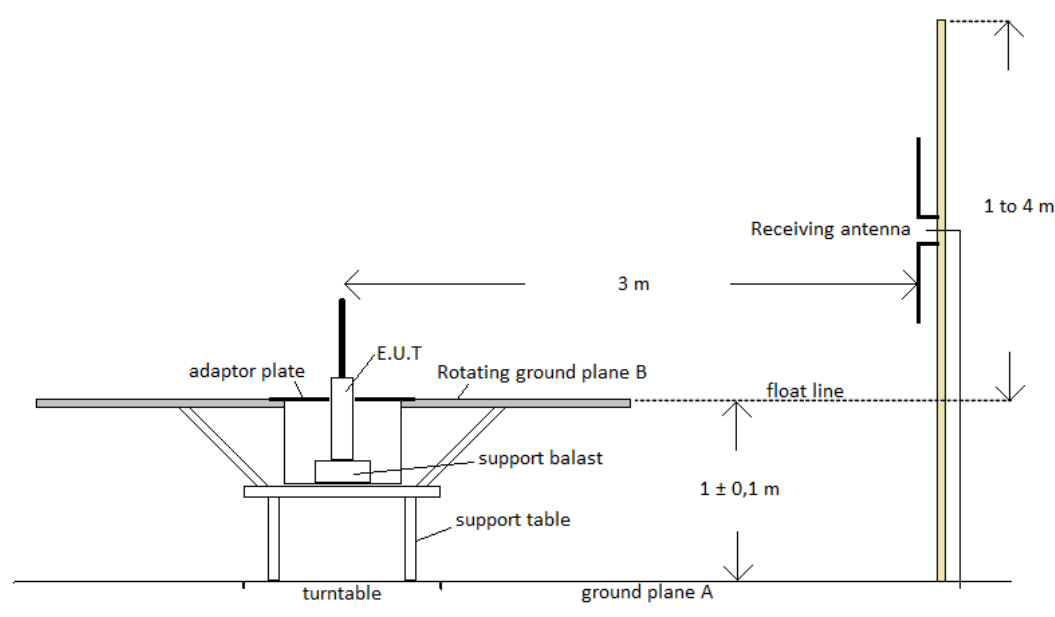

NOTE: This support is not suitable for making measurements in a fully anechoic chamber as described in clause 5.2.1.2 of ETSI TS 103 052 [3].

Figure C.1: Float-free test support

Annex D (informative): AIS message bursts

D.1 Active mode

In active mode the equipment transmits messages in a burst of 8 messages once per minute. The SOTDMA communication state of Message 1 is used to pre-announce its future transmissions.

The equipment transmits Message 1 "Position report" with the Navigational Status set to 14 and Message 14 broadcast safety related message with the text "MOB ACTIVE". Message 14 is transmitted nominally every 4 minutes and replace one of the position reports on both channels.

The equipment transmissions alternate between AIS1 and AIS2.

The 1st and 5th burst are as follows:

- AIS1, Message 1, Nav Status = 14, comm-state (time-out={7,3}, sub-message=0)
- AIS2, Message 1, Nav Status = 14, comm-state (time-out={7,3}, sub-message=0)
- AIS1, Message 1, Nav Status = 14, comm-state (time-out={7,3}, sub-message=0)
- AIS2, Message 1, Nav Status = 14, comm-state (time-out={7,3}, sub-message=0)
- AIS1, Message 14 "MOB ACTIVE"
- AIS2, Message 14 "MOB ACTIVE"
- AIS1, Message 1, Nav Status = 14, comm-state (time-out={7,3}, sub-message=0)
- AIS2, Message 1, Nav Status = 14, comm-state (time-out={7,3}, sub-message=0)

The 2nd, 4th, 6th burst are as follows:

- AIS1, Message 1, Nav Status = 14, comm-state (time-out={6,4,2}, sub-message=slot)
- AIS2, Message 1, Nav Status = 14, comm-state (time-out={6,4,2}, sub-message=slot)
- AIS1, Message 1, Nav Status = 14, comm-state (time-out={6,4,2}, sub-message=slot)
- AIS2, Message 1, Nav Status = 14, comm-state (time-out={6,4,2}, sub-message=slot)
- AIS1, Message 1, Nav Status = 14, comm-state (time-out={6,4,2}, sub-message=slot)
- AIS2, Message 1, Nav Status = 14, comm-state (time-out={6,4,2}, sub-message=slot)
- AIS1, Message 1, Nav Status = 14, comm-state (time-out={6,4,2}, sub-message=slot)
- AIS2, Message 1, Nav Status = 14, comm-state (time-out={6,4,2}, sub-message=slot)

The 3rd burst are as follows:

- AIS1, Message 1, Nav Status = 14, comm-state (time-out=5, sub-message=0)
- AIS2, Message 1, Nav Status = 14, comm-state (time-out=5, sub-message=0)
- AIS1, Message 1, Nav Status = 14, comm-state (time-out=5, sub-message=0)
- AIS2, Message 1, Nav Status = 14, comm-state (time-out=5, sub-message=0)
- AIS1, Message 1, Nav Status = 14, comm-state (time-out=5, sub-message=0)

- AIS2, Message 1, Nav Status = 14, comm-state (time-out=5, sub-message=0)
- AIS1, Message 1, Nav Status = 14, comm-state (time-out=5, sub-message=0)
- AIS2, Message 1, Nav Status = 14, comm-state (time-out=5, sub-message=0)

The 7th burst are as follows:

- AIS1, Message 1, Nav Status = 14, comm-state (time-out=1, sub-message=utc)
- AIS2, Message 1, Nav Status = 14, comm-state (time-out=1, sub-message=utc)
- AIS1, Message 1, Nav Status = 14, comm-state (time-out=1, sub-message=utc)
- AIS2, Message 1, Nav Status = 14, comm-state (time-out=1, sub-message=utc)
- AIS1, Message 1, Nav Status = 14, comm-state (time-out=1, sub-message=utc)
- AIS2, Message 1, Nav Status = 14, comm-state (time-out=1, sub-message=utc)
- AIS1, Message 1, Nav Status = 14, comm-state (time-out=1, sub-message=utc)
- AIS2, Message 1, Nav Status = 14, comm-state (time-out=1, sub-message=utc)

The 8th burst are as follows:

- AIS1, Message 1, Nav Status = 14, comm-state (time-out=0, sub-message=incr)
- AIS2, Message 1, Nav Status = 14, comm-state (time-out=0, sub-message=incr)
- AIS1, Message 1, Nav Status = 14, comm-state (time-out=0, sub-message=incr)
- AIS2, Message 1, Nav Status = 14, comm-state (time-out=0, sub-message=incr)
- AIS1, Message 1, Nav Status = 14, comm-state (time-out=0, sub-message=incr)
- AIS2, Message 1, Nav Status = 14, comm-state (time-out=0, sub-message=incr)
- AIS1, Message 1, Nav Status = 14, comm-state (time-out=0, sub-message=incr)
- AIS2, Message 1, Nav Status = 14, comm-state (time-out=0, sub-message=incr)

In the 8th burst the increment to the next burst (sub-message=incr) are randomly selected between 2 025 slots and 2 475 slots.

This pattern of transmissions is repeated. It is permissible to start the sequence on AIS2.

Message 14 is transmitted at the 1st and 5th bursts (slot-time-out = 7 and 3) thereby ensuring that all future Message 14 messages are pre-announced.

D.2 Test mode

When operating in the test mode there are one burst of 8 messages, 4 on each channel alternating:

- AIS1, Message 14 "MOB TEST"
- AIS2, Message 1, Nav Status = 15 not defined, comm-state (time-out=0, sub-message=0)
- AIS1, Message 1, Nav Status = 15 not defined, comm-state (time-out=0, sub-message=0)
- AIS2, Message 1, Nav Status = 15 not defined, comm-state (time-out=0, sub-message=0)
- AIS1, Message 1, Nav Status = 15 not defined, comm-state (time-out=0, sub-message=0)

- AIS2, Message 1, Nav Status = 15 not defined, comm-state (time-out=0, sub-message=0)
- AIS1, Message 1, Nav Status = 15 not defined, comm-state (time-out=0, sub-message=0)
- AIS2, Message 14 "MOB TEST"

It is permissible to start the sequence on AIS2.

D.3 Default message field values

On activation or if timed out in test mode, if the GNSS is unable to provide a valid position fix, then the reported position is longitude = 181° = not available = default and latitude = 91° = not available = default, COG = not available = default, SOG = not available = default, and the time stamp field is set to a value of 63.

If in active mode the GNSS is able to provide a valid position fix but that fix is subsequently lost, then the equipment continues to transmit with the last known position, COG and SOG. The time stamp field is set to a value of 63 and with the synchronization state set to 3.

Annex E (informative): Technical characteristics of class M MSLDs

E.1 General

When activated the MSLD should be capable of transmitting DSC distress messages as described in clause 5.2.1 of ETSI EN 300 338-6 [1]. DSC messages are transmitted on maritime VHF channel 70 (156 525 MHz). Transmission should only commence if the channel is not busy (Listen Before Talk) as described in clause 5.1 of ETSI EN 300 338-6 [1]. The MSLD has an integral DSC receiver capable of receiving distress acknowledgements. On receipt of a properly addressed distress acknowledgement the MSLD should stop transmitting further DSC signalling and indicate that the distress alert has been acknowledged.

When activated the MSLD transmits AIS messages that indicate the position of a person in the water. The transmitted messages should be recognized and displayed by AIS receivers in the reception range of the transmitter, and clearly distinguish the transmitter as a Man Over-Board (MOB) device. AIS TDMA Synchronization is UTC direct; the equipment does not require an AIS receiver. AIS position messages should continue to be transmitted after a DSC distress alert acknowledgement has been received and the MSLD has stopped DSC message transmissions, until the device is manually deactivated.

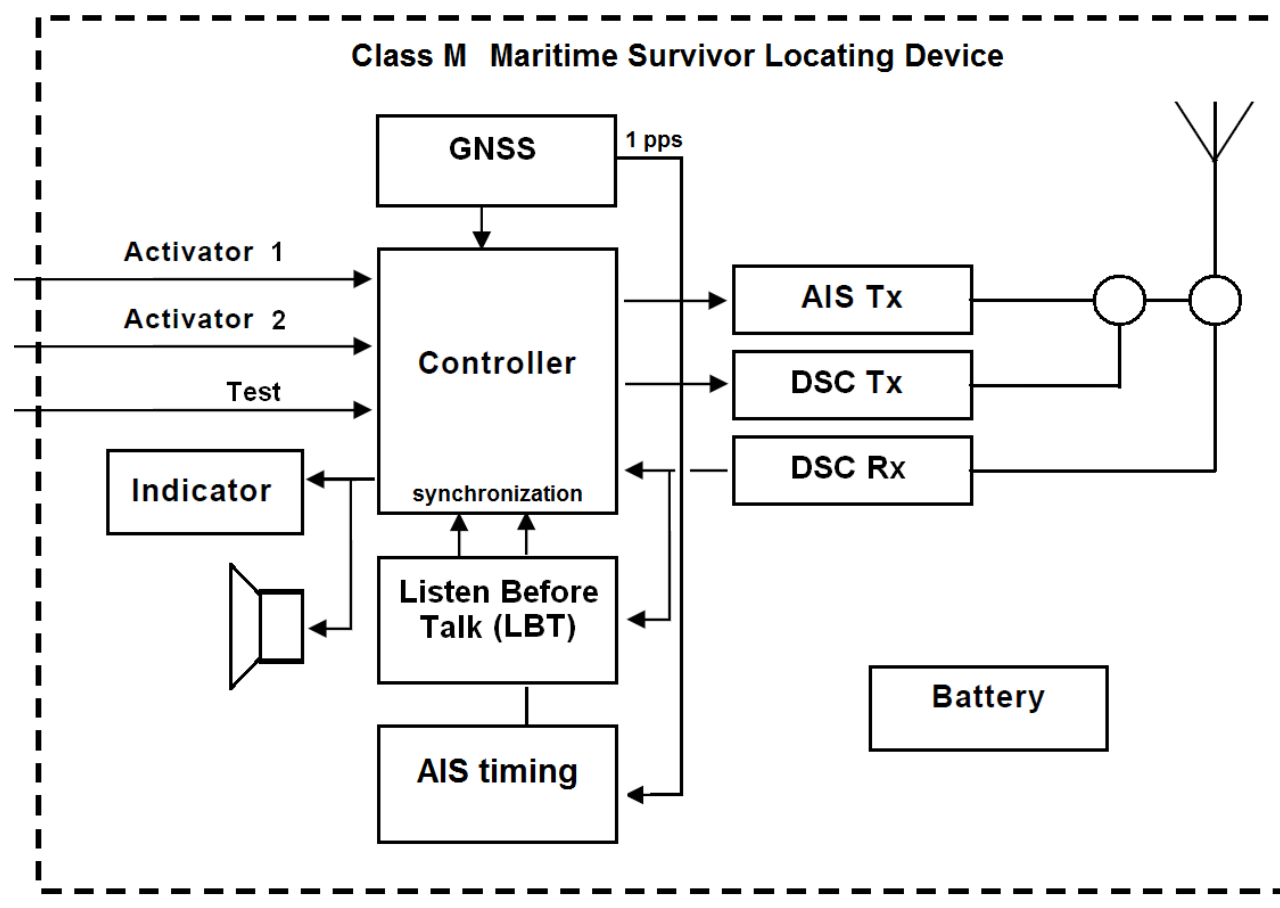

Figure E.1: Functional block diagram of Class M MSLDs

E.2 DSC transmission characteristics

Class M MSLDs transmits on marine VHF channel 70 (156 525 MHz) using DSC signalling (phase modulated G2B) as defined in clause 1.3.2 of Annex 1 of Recommendation ITU-R M.493-15 [2].

Table E.1 is derived from Recommendation ITU-R M.493-15 [2] and gives the parameters required for a class M MSLD.

Table E.1: DSC Required parameter settings

Symbol	Parameter name	Setting
CH70	Marine band channel 70	156 525 MHz
ϕM	Frequency modulation with a pre-emphasis characteristic of 6 dB/octave (phase modulation) with sub-carrier modulation	Pre-emphasis time constant 750 μ S
FSK	Sub-carrier modulation 1 300 Hz (Y-state) and 2 100 Hz (B-state)	Sub-carrier tolerance \pm 10 Hz
	Modulation index	2,0 \pm 10 %
	Modulation rate	1 200 baud
	Transmitter output power	100 mW to 500 mW ERP

Since class M MSLDs transmit with significantly lower power than other DSC devices, these devices first listen to the VHF channel 70 to ensure that it is not being used, before transmitting. The protocol for this is described in clause 5.1 of ETSI EN 300 338-6 [1].

E.3 DSC messages and protocols

DSC message content and use differs for active transmissions (active mode) and test transmissions (test mode). Both modes are specified in clause 5.2 of ETSI EN 300 338-6 [1].

E.4 AIS transmission characteristics

E.4.1 General

The AIS transmitter transmits using modified SOTDMA on two channels AIS1 and AIS2. The GNSS receiver, e.g. a GPS receiver, determines the current position of the equipment and facilitates TDMA synchronization in the UTC direct mode.

The equipment or any transmitting circuits should shutdown automatically if, under a fault condition, the transmitter remains permanently keyed for more than 2 seconds. This shutdown should be independent of the operating software. Ancillary functions (strobe light, indicators, etc.) which may continue to operate.

E.4.2 AIS messages

E.4.2.1 General

The equipment broadcasts Message 1 and Message 14, as defined in annex 8 of Recommendation ITU-R M.1371-5 [i.7]. The content of the messages differs for active transmissions (active mode) and test transmissions (test mode). The combination of these messages in burst sequences is detailed in annex D.

E.4.2.2 Active mode

For Message 1 the Navigational status should be set to "14". For message 14 the safety related text should be set to "MOB ACTIVE" (see clause D.1 for details).

E.4.2.3 Test mode

For Message 1 the Navigational status is set to "15". For message 14 the safety related text is set to "MOB TEST" (see clause D.2 for details).

E.4.3 Synchronization

E.4.3.1 General

In UTC direct mode the equipment determines slot timing using the UTC timing signal from the GNSS.

The position of the equipment should be determined at least every minute once a GNSS position fix has been obtained.

E.4.3.2 Active mode

The equipment starts transmitting as soon as a position fix, SOG, COG and UTC lock are available or within 60 seconds after activation if not. Optionally the equipment may also transmit unsynchronized using default settings (see clause D.3 for details), within a period from 10 seconds to 30 seconds after activation. This initial transmission is intended to inform the local vessel that an MOB incident has occurred and allow the position of the vessel to be recorded at that time.

NOTE: In the present document, the terms "UTC lock" and "position fix" are used independently. It is however recognized that in practice a position fix cannot be obtained without UTC lock.

The equipment should begin synchronized transmission with the correct GNSS position within 5 minutes under normal operating conditions.

The equipment continues transmission even if the position and UTC lock from the positioning system is subsequently lost or fails. The equipment should maintain, as best it can, proper timing internally if UTC lock is lost. If a position fix is lost, the equipment should continue to transmit with the last known good position (see clause D.3).

E.4.3.3 Test transmission

A single test message burst (see clause D.2) is transmitted as soon as a position fix, SOG, COG and time are available. The device transmits when UTC lock is available so that SOTDMA is properly synchronized even if the UTC parameters are invalid or out of date. If UTC lock is not available after five minutes the device should abandon the test mode without transmitting.

E.4.4 UTC

E.4.4.1 General

All AIS equipment uses UTC for synchronizing transmissions. Different GNSS systems handle time in different ways. GPS uses GPS Time which was fixed at January 1980 and is thus ahead of UTC as IERS UTC leap second corrections are not applied. Galileo uses Galileo System Time which was fixed at August 1999 and is thus also ahead of UTC. Both the GPS and Galileo constellations broadcast the correction factor between their time and UTC which is updated every time that another leap second is added to UTC by IERS. Thus when a GPS or Galileo receiver is first turned on the UTC time at its output may be offset by one or more seconds from the actual UTC until such time as it can download the latest correction factor. The version of UTC transmitted by GLONASS does not apply leap seconds and remains synchronized to UTC, but is offset by 3 hours (the time difference between Moscow Time and GMT). AIS SOTDMA relies on the correct and timely computation of UTC to determine slot timings accurately. Since the AIS slot structure repeats every two seconds, the incorrect application of a leap second when determining UTC could result in AIS transmissions beginning in the middle of a time slot rather than at the beginning of the time slot.

Care should be taken when designing with multi-constellation GNSS receivers that UTC is correctly determined and applied across different satellite systems.

Since the equipment is required to do a GNSS cold start and to transmit its first valid position within 5 minutes of activation for GPS and Galileo GNSS receivers the equipment may maintain a stored copy of the UTC parameters leap second information.

E.4.4.2 UTC parameters storage

Where manufacturers do provide a mechanism whereby the stored copy of the UTC parameters (that is leap second offset and predictions) can be kept up to date, then the GNSS cold start should not make use of any stored information other than valid leap second information.

E.4.5 Required settings

The equipment operates on dual channels, AIS1 and AIS2, in the VHF Maritime Mobile Service band. Tables E.2, E.3 and E.4 are derived from annex 2, section 2 of Recommendation ITU-R M.1371-5 [i.7] and give the parameters required for AIS equipment.

Table E.2: AIS Required parameter settings

<u>ITU-R M.1371 [i.7] Symbol</u>	<u>Parameter name</u>	<u>Setting</u>
PH.AIS1	Channel 1 (default channel 1)	161,975 MHz
PH.AIS2	Channel 2 (default channel 2)	162,025 MHz
PH.BR	Bit rate	9 600 bps
PH.TS	Training sequence	24 bits
PH.TST	Transmitter settling time (Transmit power within 20 % of final value. Frequency stable to within $\pm 1,0$ kHz of final value).	$\leq 1,0$ ms
	Ramp down time	$\leq 832 \mu\text{s}$
	Transmission duration	$\leq 26,6$ ms
	Transmitter output power	1 000 mW EIRP
NOTE: Radiated power in the present document is measured in ERP by dipole substitution. Recommendation ITU-R M.1371-5 [i.7] gives transmitter power in EIRP. A conversion factor of 2,15 dB has been applied so that 1 W EIRP is approximately 600 mW ERP.		

Table E.3: Required settings of physical layer constants

<u>ITU-R M.1371 [i.7] Symbol</u>	<u>Parameter name</u>	<u>Value</u>
PH.DE	Data encoding	NRZI
PH.FEC	Forward error correction	Not used
PH.IL	Interleaving	Not used
PH.BS	Bit scrambling	Not used
PH.MOD	Modulation	Bandwidth adapted GMSK

Table E.4: Modulation parameters of the physical layer

<u>ITU-R M.1371 [i.7] Symbol</u>	<u>Name</u>	<u>Value</u>
PH.TXBT	Transmit Bandwidth time-product	0,4
PH.MI	Modulation index	0,5

E.4.6 Minimum transmitter performance characteristics

The technical characteristics as specified in table E.5 apply to the transmitter.

Table E.5: Minimum required transmitter characteristics

Transmitter parameters	Requirements
Carrier power	Not exceeding 1 000 mW EIRP
Carrier frequency error	500 Hz (normal), 1 000 Hz (extreme)
Slotted modulation mask	-20 dBc $\Delta f_c > \pm 10$ kHz -40 dBc ± 25 kHz $< \Delta f_c < \pm 62.5$ kHz see figure 5 in clause 9.4
Transmitter test sequence and modulation Accuracy	< 3 400 Hz for Bit 0, 1 (normal and extreme) 2 400 Hz \pm 480 Hz for Bit 2, 3 (normal and extreme) 2 400 Hz \pm 240 Hz for Bit 4 ... 31 (normal, 2 400 Hz + 480 Hz extreme) For Bit 32 ... Bit 199 1 740 Hz \pm 175 Hz (normal, 1 740 Hz + 350 Hz extreme) for a bit pattern of 0101 2 400 Hz \pm 240 Hz (normal, 2 400 Hz + 350 Hz extreme) for a bit pattern of 00001111
Transmitter output power versus time	Power within mask shown in figure 5 and timings given in table 4 of clause 9.4
Spurious emissions	Not exceeding 25 μ W between 108 MHz to 137 MHz, 156 MHz to 161.5 MHz, and 1 525 MHz to 1 610 MHz

E.4.7 VHF Data Link (VDL) Access

E.4.7.1 General

The equipment uses modified SOTDMA for the transmission of message bursts as indicated in annex D.

The equipment determines its own schedule for transmission of its messages based on random selection of the first slot of the first burst. The other 7 slots within the first burst are fixed with reference to the first slot of the burst. The increment between transmission slots within a burst is 75 slots and the transmissions alternate between channels AIS1 and AIS2.

E.4.7.2 Active mode

In active mode (see figure E.2), the equipment starts with a slot-time-out = 7 in the Communication state of all Message 1 transmissions in the first burst, and thereafter the slot time-out is decreased according to table 18 in Recommendation ITU-R M.1371-5 [i.7]. Since the equipment does not have an AIS receiver, all slots should be regarded as candidates in the selection process. When time out occurs, the offset to the next set of 8 bursts is randomly selected at 1 minute \pm 6 seconds.

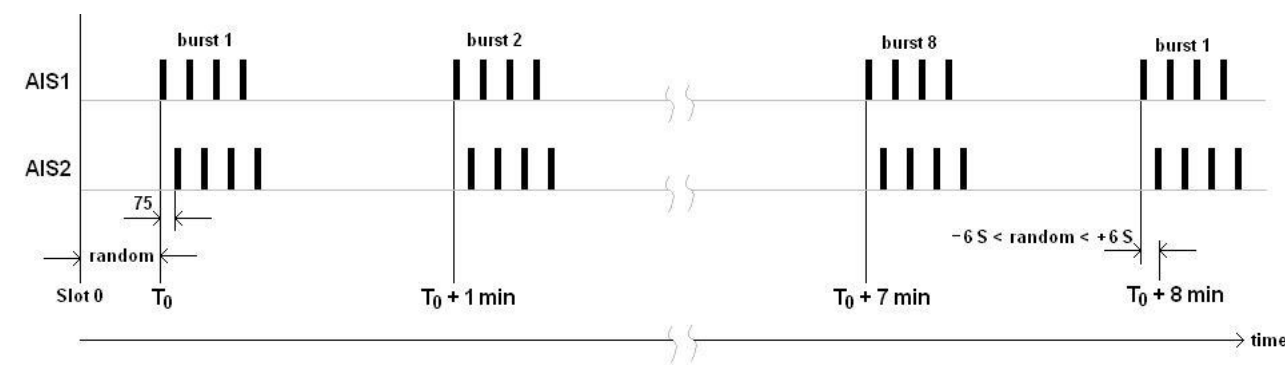

Figure E.2: Burst transmissions in active mode

All slot-time-out values of the Communication state of all Message 1 transmissions within every burst should be the same.

Two Message 14's are transmitted every 4th minute one on each channel, starting in the first minute (i.e. slot-time-out = 7 and 3), and the 5th and 6th message in the burst (see clause D.1).

Message 14 is transmitted alternately on AIS1 and AIS2.

E.4.7.3 Test mode

In test mode the equipment sets a slot-time-out = 0 and sub-message = 0 in the Communication state of all Message 1 transmissions in the first and only burst.

All slot time-out values of the Communication state of all Message 1 transmissions within every burst are the same.

Two Message 14's are transmitted one on each channel as the 1st and 8th message in the burst (see clause D.2).

E.5 Position indication

The class M MSLD has an integral GNSS receiver conforming with the requirements of clause 6 of ETSI EN 300 338-6 [1]. The device uses this source to provide position information in the DSC distress messages it transmits. MSLDs do not reply to position requests using DSC signalling, but instead indicate their position using AIS signalling as specified in clause E.4.

E.6 Power source

Class M MSLDs are normally powered by long-life, non-rechargeable batteries.

The manufacturer should establish a useful life and an expiry date for primary (non-rechargeable) batteries. The useful life is the period of time after the date of battery manufacture that the battery will continue to meet the input power requirements of the device, over the entire specified operating temperature range. The following losses need to be considered:

- a) self-testing annually with GNSS data available;
- b) self-discharge of the battery;
- c) stand-by loads.

The expiry date of the battery is the date of battery cell manufacture plus no more than 1/2 of the useful life of the battery. The battery should be clearly and durably marked with its date of manufacture.

E.7 Own vessel MMSI

The Own vessel MMSI applies to closed loop MSLDs only (devices marked DSC-MOB-C).

An MSLD marked DSC-MOB-C has a facility to be programmed with its own vessel MMSI as described in the supplied user documentation.

The MSLD should be programmed with the MMSI of its own vessel or group prior to deployment on ship.

It should be possible for an MSLD's own vessel MMSI to be re-programmed in the field, for example when devices are moved from one vessel to be stowed on another vessel. It should be possible for users to re-programme the own vessel MMSI without devices having to be returned to the manufacturer.

If the own vessel MMSI is not entered or not valid the MSLD should indicate this during testing and should behave as an open-loop device when activated.

Annex F (informative): Grey-box testing of class M MSLDs

F.1 Definitions

A black-box test is one where no knowledge of the internal structure of the equipment to be tested is required to be known in order to fully perform the test. Black-box testing is preferred for compliance testing by market surveillance authorities because it can be performed on any sample of a product without any reference to the manufacturer. The present document specifies black-box tests wherever possible.

A white-box test is one where the tester has access to all the internal components of the equipment. This is the type of testing performed by manufacturers in order to debug and verify the correct operation of products during design, development and manufacture.

A grey-box test is one where some partial knowledge the internal structure of a product is required in order to complete the test. It may also require the use of equipment such as programming interfaces to put a product into a test mode that is necessary to perform the test but would not normally be a mode the product would operate in. It is essential that manufacturers make available on request the equipment and instructions necessary to perform grey-box testing. Grey-box testing is only specified in the present document where a suitable black-box test is unavailable or inferior.

F.2 Test interface

It is essential that manufacturers incorporate a test interface whereby any sample of the equipment selected for testing can be placed into any of the required test modes specified in clause F.3. In addition it is necessary for the test interface to permit easy access to the T_0 timing signal used for the AIS timing tests described in clauses 9.4, 9.5 and 9.6. That is the edge trigger timing signal corresponding to T_0 in figure 5 of clause 9.4.

Given that MSLDs are required to be watertight it is not unreasonable for a manufacture to hide the test interface within the watertight enclosure in such a way that access to it can only be achieved by opening the watertight enclosure and rendering the device no longer watertight.

How the test interface is accessed and the technical information necessary should be fully specified and available on request or published openly. Manufacturers might consider there is some merit in incorporating the programming of the Own vessel MMSI (clause E.7) into the test interface for convenience.

F.3 Test modes

F.3.1 Supported Modes

The following test modes should be supported by the test interface described in clause F.2 and their use fully documented:

- i) Continuous transmission on channel 70 with no modulation as specified in clause 6.4.4.
- ii) Continuous transmission on channel 70 with continuous B / Y state modulation as specified in clause 6.4.1.
- iii) Continuous transmission on channel 70 with alternating B / Y state modulation as specified in clause 6.4.2.
- iv) Continuous transmission on channel 70 with random B / Y state modulation as specified in clause 6.4.3.
- v) Continuous transmission on either channel AIS1 or AIS2 (as selected) with no modulation as specified in clause 6.5.4.
- vi) The transmission on either channel AIS1 or AIS2 (as selected) of a single AIS frame containing AIS standard test signal number 1 as specified in clause 6.5.1 followed by return to the not-transmitting state.

- vii) The transmission on either channel AIS1 or AIS2 (as selected) of a single AIS frame containing AIS standard test signal number 2 as specified in clause 6.5.2 followed by return to the not-transmitting state.
- viii) The transmission on either channel AIS1 or AIS2 (as selected) of a single AIS frame containing AIS standard test signal number 3 as specified in clause 6.5.3 followed by return to the not-transmitting state.
- ix) Continuous transmission on either channel AIS1 or AIS2 (as selected) with continuous modulation of standard test signal number 3 as specified in clause 6.5.3 (as required by clause 8.9.2).
- x) Continuous reception on channel 70 with DSC acknowledgement decode operational and each successful decode indicated as described in clause 4.3.2.2 iv) (as required by clauses 8.9.2 and 10).

F.3.2 DSC Receiver test mode

Only the DSC receiver is tested in the present document. Testing of the GNSS receiver is outside the scope of the present document. The DSC receiver tests specified in clause 10 require that the manufacturer implement the test mode specified in clause F.3, item x), the visual indicator specified in clause 4.3.2.2, item iv) and that it is possible to make a 50 Ω connection to the DSC receiver input of any sample of the equipment selected for testing (see clause 6.3.3).

Annex G (informative): Maximum Measurement Uncertainty

The measurements described in the present document are based on the following assumptions:

- the measured value related to the corresponding limit is used to decide whether an equipment meets the requirements of the present document;
- the value of the measurement uncertainty for the measurement of each parameter is included in the test report.

Table G.1 shows the recommended values for the maximum measurement uncertainty figures.

Table G.1: Maximum measurement uncertainty

<u>Parameter</u>	<u>Maximum uncertainty</u>
<u>Radio Frequency (RF)</u>	$\pm 1 \times 10^{-7}$
<u>Radiated emission of transmitter</u>	± 6 dB
<u>Conducted RF power variations using a test fixture</u>	$\pm 0,75$ dB
<u>Maximum frequency deviation:</u>	
- <u>within 300 Hz to 6 kHz of modulation frequency</u>	± 5 %
- <u>within 6 kHz to 25 kHz of modulation frequency</u>	± 3 dB
<u>Deviation limitation</u>	± 5 %
<u>Adjacent channel power</u>	± 5 dB
<u>Conducted spurious emission of transmitter</u>	± 4 dB
<u>Audio output power</u>	$\pm 0,5$ dB
<u>Amplitude characteristics of receiver limiter</u>	$\pm 1,5$ dB
<u>Sensitivity at 20 dB SINAD</u>	± 3 dB
<u>Conducted emission of receiver</u>	± 3 dB
<u>Two-signal measurement</u>	± 4 dB
<u>Three-signal measurement</u>	± 3 dB
<u>Transmitter transient time</u>	± 20 %
<u>Transmitter transient frequency</u>	± 250 Hz
<u>LBT timing accuracy</u>	± 5 %

Annex H (informative): Checklist

This annex provides a traceability of the technical parameters for article 3.2 of Directive 2014/53/EU [i.1] defined in ETSI EG 203 336 [i.3] with the related technical requirements defined in the present document. If a technical parameter for article 3.2 of Directive 2014/53/EU [i.1] defined in ETSI EG 203 336 [i.3] has not been included in the present document, an explanation is provided. An explanation is also provided whenever a technical parameter defined in ETSI EG 203 336 [i.3] is covered by an alternative technical requirement.

Table H.1

<u>Technical Parameters defined in ETSI EG 203 336 [i.3]</u>	<u>Clauses of the present document</u>	<u>Comments</u>
Transmitter Parameters		
Transmitter power limits and accuracy	<u>8.2</u> <u>8.3</u> <u>9.2</u> <u>9.3</u>	
Transmitter Spectrum mask	<u>8.4</u> <u>9.3</u>	For the DSC transmitter, OOB emissions are specified in terms of Adjacent channel power.
Transmitter frequency stability	<u>8.1</u> <u>8.6</u> <u>9.1</u>	
Transmitter Intermodulation attenuation	<u>NA</u>	Transmitter Intermodulation attenuation is associated with multiple transmitters on a common site or shared antenna which is not the case here.
Transmitter Unwanted emissions (OOB and spurious domains)	<u>8.4</u> <u>8.9</u>	
Transmitter Time domain characteristics (e.g. the duty cycle, turn-on and turn-off, frequency hopping cycle, dynamic changes of modulation scheme and others)	<u>8.7</u> <u>8.8</u> <u>9.6</u>	
Transmitter Transients	<u>8.5</u> <u>9.4</u> <u>9.5</u>	
Receiver Parameters		
Receiver sensitivity	<u>10.1</u>	
Receiver co-channel rejection	<u>10.2</u>	
Adjacent channel/band Selectivity	<u>10.3</u>	
Spurious response Rejection	<u>10.4</u>	
Receiver blocking	<u>10.6</u>	
Receiver radio-frequency intermodulation	<u>10.5</u>	
Receiver dynamic range	<u>10.7</u>	
Reciprocal mixing	<u>NA</u>	Reciprocal mixing is a phenomenon related to the close-in phase noise of the local oscillator. As such it will be swamped by Adjacent channel signals which are measured.
Receiver unwanted emissions in the spurious domain	<u>8.9</u>	

Annex I (informative): Change History

Version	Information about changes
V1.1.1	First published version.
<u>V2.0.1</u>	<u>Major revision resulting from Recommendation ITU-R M.2135.0 to include testing of AIS transmitter</u> <u>Aligned with ETSI EN 300 025 V2.2.1. Extension to article 3.3(g) in alignment with Decision 2013/638/EU</u> <u>on GMDSS.</u>

History

Document history		
<u>V1.1.0</u>	<u>November 2016</u>	<u>EN Approval Procedure</u> AP 20170227: 2016-11-29 to 2017-02-27
V1.1.1	March 2017	Publication
<u>V2.0.1</u>	<u>January 2022</u>	<u>EN Approval Procedure</u> AP 20220412: 2022-01-12 to 2022-04-12
<u>V2.1.0</u>	<u>August 2022</u>	<u>Vote</u> V 20221014: 2022-08-15 to 2022-10-14
<u>V2.1.1</u>	<u>October 2022</u>	<u>Publication</u>