

Summary
09/08/2016 15:43:32

Differences exist between documents.

New Document:

[en_303084v020101p](#)

39 pages (384 KB)

09/08/2016 15:43:17

Used to display results.

Old Document:

[en_303084v010101p](#)

36 pages (204 KB)

09/08/2016 15:43:17

[Get started: first change is on page 1.](#)

No pages were deleted

How to read this report

Highlight indicates a change.

Deleted indicates deleted content.

 indicates pages were changed.

 indicates pages were moved.

ETSI EN 303 084 V2.1.1 (2016-08)



**Ground Based Augmentation System (GBAS)
VHF ground-air Data Broadcast (VDB);
Technical characteristics and methods of measurement
for ground-based equipment;
Harmonised Standard covering the essential requirements
of article 3.2 of the Directive 2014/53/EU**

Reference

REN/ERM-JTFEA-19

Keywords

aeronautical, AM, DSB, harmonised standard,
radio, testing, VHF

ETSI

650 Route des Lucioles
F-06921 Sophia Antipolis Cedex - FRANCE

Tel.: +33 4 92 94 42 00 Fax: +33 4 93 65 47 16

Siret N° 348 623 562 00017 - NAF 742 C
Association à but non lucratif enregistrée à la
Sous-Préfecture de Grasse (06) N° 7803/88

Important notice

The present document can be downloaded from:
<http://www.etsi.org/standards-search>

The present document may be made available in electronic versions and/or in print. The content of any electronic and/or print versions of the present document shall not be modified without the prior written authorization of ETSI. In case of any existing or perceived difference in contents between such versions and/or in print, the only prevailing document is the print of the Portable Document Format (PDF) version kept on a specific network drive within ETSI Secretariat.

Users of the present document should be aware that the document may be subject to revision or change of status. Information on the current status of this and other ETSI documents is available at

<https://portal.etsi.org/TB/ETSIDeliverableStatus.aspx>

If you find errors in the present document, please send your comment to one of the following services:

<https://portal.etsi.org/People/CommitteeSupportStaff.aspx>

Copyright Notification

No part may be reproduced or utilized in any form or by any means, electronic or mechanical, including photocopying and microfilm except as authorized by written permission of ETSI.

The content of the PDF version shall not be modified without the written authorization of ETSI.

The copyright and the foregoing restriction extend to reproduction in all media.

© European Telecommunications Standards Institute 2016.

All rights reserved.

DECT™, PLUGTESTS™, UMTS™ and the ETSI logo are Trade Marks of ETSI registered for the benefit of its Members. 3GPP™ and LTE™ are Trade Marks of ETSI registered for the benefit of its Members and of the 3GPP Organizational Partners. GSM® and the GSM logo are Trade Marks registered and owned by the GSM Association.

Contents

Intellectual Property Rights	5
Foreword.....	5
Modal verbs terminology	5
Executive Summary	6
Introduction	6
1 Scope	7
2 References	7
2.1 Normative references	7
2.2 Informative references.....	7
3 Definitions and abbreviations.....	8
3.1 Definitions.....	8
3.2 Abbreviations	9
4 Technical requirements specifications	10
4.1 Environmental profile.....	10
4.2 Conformance requirements	10
4.2.1 Transmitter requirements.....	10
4.2.1.0 Applicability	10
4.2.1.1 Frequency error	10
4.2.1.1.1 Requirement	10
4.2.1.1.2 Conformance	10
4.2.1.2 Transmitter power	11
4.2.1.2.1 Requirement	11
4.2.1.2.2 Conformance	11
4.2.1.3 Adjacent channel power	11
4.2.1.3.1 Requirement	11
4.2.1.3.2 Conformance	12
4.2.1.4 Spurious emissions.....	13
4.2.1.4.1 Conducted emissions	13
4.2.1.4.2 Radiated emissions - cabinet radiation	15
4.2.1.5 Intermodulation attenuation	15
4.2.1.5.1 Requirements	15
4.2.1.5.2 Conformance	15
4.2.1.6 Transient behaviour of the transmitter	15
4.2.1.6.1 RF power rise time	15
4.2.1.6.2 RF power release time	17
4.2.1.7 Modulation Accuracy - Symbol constellation error	17
4.2.1.7.1 Requirement	17
4.2.1.7.2 Conformance	17
4.2.1.8 Emissions in unassigned time slots	18
4.2.1.8.1 Requirement	18
4.2.1.8.2 Conformance	18
4.2.2 Receiver requirements	19
4.2.2.1 Applicability	19
4.2.2.2 Sensitivity	19
4.2.2.2.1 Requirements	19
4.2.2.2.2 Conformance	20
4.2.2.3 Symbol rate capture range	20
4.2.2.3.1 Requirements	20
4.2.2.3.2 Conformance	21
4.2.2.4 Co-channel rejection	21
4.2.2.4.1 Requirements	21
4.2.2.4.2 Conformance	22
4.2.2.5 Adjacent Channel selectivity	23

4.2.2.5.1	Requirements	23
4.2.2.5.2	Conformance	25
4.2.2.6	Spurious response rejection.....	27
4.2.2.6.1	Requirements	27
4.2.2.6.2	Conformance	28
4.2.2.7	Spurious emissions.....	29
4.2.2.7.1	Conducted spurious emission	29
4.2.2.7.2	▲ Cabinet radiation	30
4.2.2.8	Out-of-band Intermodulation	30
4.2.2.8.1	Requirements	30
4.2.2.8.2	Conformance	31
5	General test conditions for compliance with technical requirements.....	32
5.1 ▲	Environmental conditions for testing	32
5.1.0	General Requirements	32
5.1.1	Normal and extreme test conditions.....	32
5.1.1.0	General	32
5.1.1.1	Normal temperature and humidity	32
5.1.1.2	Normal power sources.....	33
5.1.1.2.1	Mains voltage and frequency.....	33
5.1.1.2.2	Other power sources	33
5.1.2	Extreme test conditions.....	33
5.1.2.1	Extreme temperatures.....	33
5.1.2.2	Procedure for tests at extreme temperatures.....	33
5.1.2.2.1	General	33
5.1.2.2.2	Low temperature.....	33
5.1.2.3	Extreme values of test power sources	34
5.1.2.4	Other power sources.....	34
5.1.3	Test power source	34
5.2	Interpretation of the measurement results	34
Annex A (normative):	Relationship between the present document and the essential requirements of Directive 2014/53/EU	36
Annex B (informative):	Bibliography	38
History		39

Intellectual Property Rights

IPRs essential or potentially essential to the present document may have been declared to ETSI. The information pertaining to these essential IPRs, if any, is publicly available for **ETSI members and non-members**, and can be found in ETSI SR 000 314: *"Intellectual Property Rights (IPRs); Essential, or potentially Essential, IPRs notified to ETSI in respect of ETSI standards"*, which is available from the ETSI Secretariat. Latest updates are available on the ETSI Web server (<https://ipr.etsi.org/>).

Pursuant to the ETSI IPR Policy, no investigation, including IPR searches, has been carried out by ETSI. No guarantee can be given as to the existence of other IPRs not referenced in ETSI SR 000 314 (or the updates on the ETSI Web server) which are, or may be, or may become, essential to the present document.

Foreword

This **Harmonised** European Standard (EN) has been produced by ETSI Technical Committee Electromagnetic compatibility and Radio spectrum Matters (ERM).

The present document has been prepared under the Commission's standardisation request C(2015) 5376 final [1.7] to provide one voluntary means of conforming to the essential requirements of Directive 2014/53/EU on the harmonisation of the laws of the Member States relating to the making available on the market of radio equipment and repealing Directive 1999/5/EC [i.1].

The present document provides the technical procedures and limits for compliance with article 3.2 of the Directive 2014/53/EU [i.1] for VHF ground-air digital broadcast of Ground-Based Augmentation System (GBAS).

Once the present document is cited in the Official Journal of the European Union under that Directive, compliance with the normative clauses of the present document given in Table A.1 confers, within the limits of the scope of the present document, a presumption of conformity with the corresponding essential requirements of that Directive, and associated EFTA regulations.

National transposition dates

Date of adoption of this EN:	2 August 2016
Date of latest announcement of this EN (doa):	30 November 2016
Date of latest publication of new National Standard or endorsement of this EN (dop/e):	31 May 2017
Date of withdrawal of any conflicting National Standard (dow):	31 May 2018

Modal verbs terminology

In the present document **"shall", "shall not", "should", "should not", "may", "need not", "will", "will not", "can"** and **"cannot"** are to be interpreted as described in clause 3.2 of the [ETSI Drafting Rules](#) (Verbal forms for the expression of provisions).

"must" and **"must not"** are **NOT** allowed in ETSI deliverables except when used in direct citation.

Executive Summary

The present document applies to VDB ground-air digital broadcast using Differential Eight Phase Shift Keying (D8PSK) of Ground-Based Augmentation System GBAS, intended for channel increments of 25 kHz. The VDB system provides data broadcast from ground based to aircraft systems, operating in the VHF band (108,000 MHz to 117,975 MHz). The scope of the present document is limited to ground based stations and is restricted to the civil use of GBAS with horizontally polarized signals (GBAS/H).

Introduction

The present document states the technical specifications for ground-based equipment implementing Very High Frequency (VHF) Data Broadcast (VDB) air interface, operating in the VHF band (108,000 MHz to 117,975 MHz) in increments of 25 kHz.

NOTE: In ICAO Annex 10, Vol. 1 [2], clause 7.2.3 in attachment D it is stated: "...Until compatibility criteria are developed for GBAS VDB and ILS, VDB cannot be assigned to channels below 112,025 MHz."

1 Scope

The present document applies to VDB ground-air digital broadcast using Differential Eight Phase Shift Keying (D8PSK) of Ground-Based Augmentation System GBAS, intended for channel increments of 25 kHz. The VDB system provides data broadcast from ground based to aircraft systems, operating in the VHF band (108,000 MHz to 117,975 MHz). The scope of the present document is limited to ground based stations and is restricted to the civil use of GBAS with horizontally polarized signals (GBAS/H).

The present document contains requirements to demonstrate that "... Radio equipment shall be so constructed that it both effectively uses and supports the efficient use of radio spectrum in order to avoid harmful interference" [i.1].

In addition to the present document, other ENs that specify technical requirements in respect of essential requirements under other parts of article 3 of the Radio Equipment Directive [i.1] as well as essential requirements under the SES Interoperability Regulation 552/2004 [i.2] and related implementing rules and/or essential requirements under the EASA basic Regulation (EC) No 216/2008 [i.5] and Regulation (EC) No 1108/2009 [i.6] may apply to equipment within the scope of the present document.

2 References

2.1 Normative references

References are either specific (identified by date of publication and/or edition number or version number) or non-specific. For specific references, only the cited version applies. For non-specific references, the latest version of the referenced document (including any amendments) applies.

Referenced documents which are not found to be publicly available in the expected location might be found at <http://docbox.etsi.org/Reference>.

NOTE: While any hyperlinks included in this clause were valid at the time of publication, ETSI cannot guarantee their long term validity.

The following referenced documents are necessary for the application of the present document.

- [1] ETSI EN 300 113-1 (V1.7.1) (11-2011): "Electromagnetic compatibility and Radio spectrum Matters (ERM); Land mobile service; Radio equipment intended for the transmission of data (and/or speech) using constant or non-constant envelope modulation and having an antenna connector; Part 1: Technical characteristics and methods of measurement".
- [2] ICAO Annex 10: "Aeronautical Telecommunications", Vol. I, November 2014.

2.2 Informative references

References are either specific (identified by date of publication and/or edition number or version number) or non-specific. For specific references, only the cited version applies. For non-specific references, the latest version of the referenced document (including any amendments) applies.

NOTE: While any hyperlinks included in this clause were valid at the time of publication, ETSI cannot guarantee their long term validity.

The following referenced documents are not necessary for the application of the present document but they assist the user with regard to a particular subject area.

- [i.1] Directive 2014/53/EU of the European Parliament and of the Council of 16 April 2014 on the harmonisation of the laws of the Member States relating to the making available on the market of radio equipment and repealing Directive 1999/5/EC.

- [i.2] Regulation (EC) 552/2004 of the European Parliament and Council of 10 March 2004 on the interoperability of the European Air Traffic Management network (the interoperability Regulation). OJ L96, 31.03.2004, p. 26 as amended by Regulation EC No 1070/2009, OJ L 300, 14/11/2009, p. 34.
- [i.3] ETSI TR 100 028-1 (V1.4.1): "Electromagnetic compatibility and Radio spectrum Matters (ERM); Uncertainties in the measurement of mobile radio equipment characteristics; Part 1".
- [i.4] ETSI TR 100 028-2 (V1.4.1): "Electromagnetic compatibility and Radio spectrum Matters (ERM); Uncertainties in the measurement of mobile radio equipment characteristics; Part 2".
- [i.5] Regulation (EC) No 216/2008 of the European Parliament and of the Council of 20 February 2008 on common rules in the field of civil aviation and establishing a European Aviation Safety Agency, and repealing Council Directive 91/670/EEC, Regulation (EC) No 1592/2002 and Directive 2004/36/EC.
- [i.6] Regulation (EC) No 1108/2009 of the European Parliament and of the Council of 21 October 2009 amending Regulation (EC) No 216/2008 in the field of aerodromes, air traffic management and air navigation services and repealing Directive 2006/23/EC.
- [i.7] Commission Implementing Decision C(2015) 5376 final of 4.8.2015 on a standardisation request to the European Committee for Electrotechnical Standardisation and to the European Telecommunications Standards Institute as regards radio equipment in support of Directive 2014/53/EU of the European Parliament and of the Council.

3 Definitions and abbreviations

3.1 Definitions

For the purposes of the present document, the terms and definitions given in the Radio Equipment Directive [i.1] and the following apply:

adjacent channel power: amount of the modulated RF signal power transmitted outside of the assigned channel

NOTE: Adjacent channel power includes discrete spurious, signal sidebands and noise density (including phase noise) at the transmitter output.

adjacent channel rejection: receiver's ability to demodulate the desired signal and meet the uncorrected BER requirement in the presence of an interfering signal in an adjacent channel

NOTE: The ratio (in dB) between the adjacent interfering signal level and the desired signal level necessary to achieve the specified minimum uncorrected BER, is the Adjacent Channel Rejection (ACR) ratio.

Aeronautical Mobile Route Service (AM(R)S): mobile service between ground based stations and airborne stations, in which survival craft stations may participate

average transmitter output power: average power supplied to the antenna transmission line by a transmitter during an interval of time sufficiently long, compared with the lowest frequency encountered in the modulation, taken under normal operating conditions

Bit Error Rate (BER): ratio between the number of erroneous bits received and the total number of bits received

NOTE: The uncorrected BER represents the BER without the benefit of Forward Error Correction (FEC).

Co-Channel Interference (CCI): capability of a receiver to demodulate the desired signal and achieve the minimum specified BER performance in the presence of an unwanted signal at the same assigned channel

NOTE: The ratio (in dB) between the wanted signal level and the unwanted signal level is the co-channel interference ratio.

conducted measurements: measurements which are made using a direct RF connection to the equipment under test

data rate: with a nominal data rate of 31 500 bits/s, the VDB symbol rate is expected to be 10 500 symbols/s

environmental profile: range of environmental conditions under which equipment within the scope of the present document is required to comply with the provisions of the present document ▲

▲ **ground based station:** aeronautical station equipment, in the Aeronautical Mobile Route Service (AM(R)S), for use with an external antenna and intended for use at a fixed location

radiated measurements: measurements which involve the measurement of a radiated field

spurious emissions: conducted RF emissions on a frequency or frequencies which are outside the necessary bandwidth and the level of which may be reduced without affecting the corresponding transmission of information

NOTE: Spurious emissions include parasitic emissions, intermodulation products and frequency conversion products.

3.2 Abbreviations

For the purposes of the present document, the following abbreviations apply:

AC	Alternating Current
ACR	Adjacent Channel Rejection
AGC	Automatic Gain Control
AM	Amplitude Modulation
AM(R)S	Aeronautical Mobile (Route) Service
BER	Bit Error Rate
CCI	Co-Channel Interference ▲
CW	Continuous Wave
D8PSK	Differential Eight Phase Shift Keying
DSB	Double Side Band
EASA	European Aviation Safety Agency
EC	European Commission
EFTA	European Free Trade Association
EU	European Union
EVM	Error Vector Magnitude
FC	Frequency Counter
FEC	Forward Error Correction
FM	Frequency Modulation
GBAS	Ground Based Augmentation System
ICAO	International Civil Aviation Organization
ILS	Instrument Landing System
MFR	Message Failure Rate
PC	Personal Computer
PPS	Pulse Per Second ▲
RBW	Resolution BandWidth
RF	Radio Frequency
RMS	Root Mean Square
SA	Spectrum Analyser
SES	Single European Sky
SWT	Sweep Time
TUT	Transmitter Under Test
VBW	Video BandWidth
VDB	VHF Data Broadcast
VHF	Very High Frequency
VSA	Vector Signal Analyser ▲▲▲

4 Technical requirements specifications

4.1 Environmental profile

The technical requirements of the present document apply under the environmental profile for operation of the equipment, which shall be declared by the supplier. The equipment shall comply with all the technical requirements of the present document at all times when operating within the boundary limits of the declared operational environmental profile.

4.2 Conformance requirements

4.2.1 Transmitter requirements

4.2.1.0 Applicability

All the technical requirements in clause 4.2.1 shall only be applicable for equipment containing a transmitter.

4.2.1.1 Frequency error

4.2.1.1.1 Requirement

The frequency of the RF carrier shall be within ± 2 ppm of the selected frequency as specified in ICAO Annex 10 Vol I Appendix B 3.6.2.1 [2].

To facilitate the measurement of the RF carrier frequency, the transmitter shall provide a CW mode.

4.2.1.1.2 Conformance

The following conformance test shall be performed to comply with the technical requirement in clause 4.2.1.1.1.

The following equipment is required:

- Frequency counter (FC) or spectrum analyser (SA).
- **Optional:** attenuator to assure best measurement operation of the FC or the SA.

The measurement procedure consists of the following steps:

- Step 1: Connect the equipment as shown in Figure 1.
- Step 2: Tune the transmitter under test (TUT) to 117,950 MHz.
- Step 3: Key the transmitter under test (TUT) "on" and set the Unit under test to transmit an unmodulated RF carrier signal.
- Step 4: Set the frequency counter (or SA) to capture transmitted signal and determine its frequency.
- Step 5: Check that the measured frequency is consistent with the requirements according to clause 4.2.1.1.1.

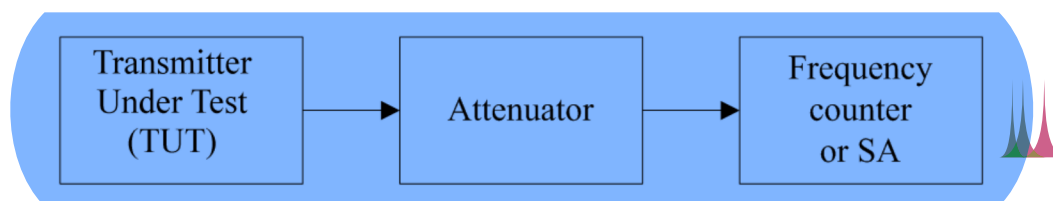

Figure 1: Frequency error measurement

4.2.1.2 Transmitter power

4.2.1.2.1 Requirement

The manufacturers declared output power shall be measured as an average over the period of the synchronization and ambiguity resolution field of the burst as specified in clause 3.7.3.5.4.4.1.2 of ICAO Annex 10 [2]. The measured power shall be ± 1 dB of the manufacturer's declared output power.

The requirements of the present document shall also be met for all power output levels at which the transmitter is intended to operate into 50 Ω . For practical reasons measurements shall be performed only at the lowest and the highest power output level at which the transmitter is intended to operate. ⚠

⚠ 4.2.1.2.2 Conformance

The following conformance test shall be performed to comply with the technical requirement in clause 4.2.1.2.1.

The following equipment is required:

- Transmitter under test (TUT).
- Spectrum analyser (SA).
- Suitable attenuator to assure best measurement operation of the SA.

The measurement procedure consists of the following steps:

- Step 1: Connect the equipment as shown in Figure 2.
- Step 2: Tune the transmitter to the test frequency 108,025 MHz.
- Step 3: Key the transmitter under test (TUT) "on", set the output power of the TUT to its lowest declared output power level and modulate the carrier with messages from the transmission generator.
- Step 4: Set the VSA to capture the transmitted VDB signal and determine the transmitter output power as an average over the period of the synchronization and ambiguity resolution field of the burst as specified in clause 3.7.3.5.4.4.1.2 of ICAO Annex 10 [2].
- Step 5: Repeat Steps 3 to 4 with an output power level equals to the highest declared output power level of the transmitter under test.
- Step 6: Repeat Steps 2 to 5 at the two remaining test frequencies:
- 112,00 MHz.
 - 117,950 MHz.
- Step 7: Check that the measured output power is consistent with the manufacturer's declared output power according to clause 4.2.1.2.1, and remains so at all three test channels.

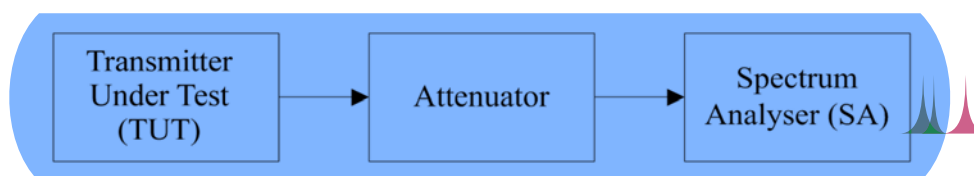

⚠⚠ Figure 2: Output power measurement

4.2.1.3 Adjacent channel power

4.2.1.3.1 Requirement

The amount of power during transmission under all operating conditions when measured over a 25 kHz bandwidth centred on the adjacent channel shall not exceed the values shown in Table 1 and specified in Table 3.7.3.5-1 of ICAO Annex 10 [2].

Table 1: GBAS broadcast power transmitted in adjacent channels

Channel	Relative Power	Maximum Power
1 st Adjacent	-40 dBc	12 dBm
2 nd Adjacent	-65 dBc	-13 dBm
4 th Adjacent	-74 dBc	-22 dBm
8 th Adjacent	-88,5 dBc	-36,5 dBm
16 th Adjacent	-101,5 dBc	-49,5 dBm
32 th Adjacent	-105 dBc	-53 dBm
64 th Adjacent	-113 dBc	-61 dBm
76 th Adjacent	-115 dBc	-63 dBm

NOTE 1: The maximum power applies if the authorized transmitter power exceeds 150 W.
NOTE 2: The relationship is linear between single adjacent points designated by the adjacent channels identified above.

4.2.1.3.2 Conformance

4.2.1.3.2.1 Measurement method for the first adjacent channel

The following conformance test shall be performed to comply with the technical requirement in clause 4.2.1.3.1.

The following equipment is required:

- Transmitter under test (TUT).
- Spectrum analyser (SA).
- Suitable attenuator to assure best measurement operation of the SA.

The measurement procedure consists of the following steps:

- Step 1: Connect the equipment as shown in Figure 3.
- Step 2: Switch the unit under test on and modulate the carrier with messages from the TUT.
- Step 3: Tune the transmitter to the test frequency 108,025 MHz.
- Step 4: Set the spectrum analyser to capture the transmitted VDB signal including first upper and lower adjacent channel and determine the transmitter first upper and first lower adjacent channel power as an average over the period of the synchronization and ambiguity resolution field of the burst as specified in ICAO Annex 10 [2], clause 3.7.3.5.4.4.1.2. Record the highest of the two measured values as first adjacent channel power.
- Step 5: Check that the first adjacent channel power is lower than the first adjacent channel power limit (defined in clause 4.2.1.3.1).
- Step 6: Repeat Steps 3 to 5 at the remaining test frequencies:
- 112,00 MHz.
 - 117,950 MHz.



Figure 3: First adjacent channel power measurement (also applicable for symbol constellation error measurements)

4.2.1.3.2.2 Measurement method for the second and higher adjacent channels

The following conformance test shall be performed to comply with the technical requirement in clause 4.2.1.3.1.

The following equipment is required:

- Transmitter under test (TUT).
- Spectrum analyser (SA).
- **Optional:** Adequate filter to assure a dynamic range of the measurement system for the adjacent channel limits in excess of 10 dB more than the requirements given in clause 4.2.1.3.1.

The measurement procedure consists of the following steps:

- Step 1: Connect the equipment as shown in Figure 4.
- Step 2: Key the transmitter under test "on" and modulate the carrier with messages from the transmission generator.
- Step 3: Tune the transmitter to the test frequency 108,025 MHz.
- Step 4: Set the spectrum analyser to capture the transmitted VDB signal including second upper and lower adjacent channel. Determine the second upper and lower adjacent channel power level as an average over the period of the synchronization and ambiguity resolution field of the burst as specified in clause 3.7.3.5.4.4.1.2 of ICAO Annex 10 [2]. Record for each of the adjacent channels the highest value of the corresponding upper and lower adjacent channels.
- Step 5: Record the higher of the two channel power levels measured in step 4. Check that the adjacent channel power is lower than the requirement (defined in clause 4.2.1.3.1).
- Step 6: Repeat Step 4 at the remaining higher upper and lower adjacent channels.
- Step 7: Repeat Steps 3 to 5 at the remaining test channels.

NOTE: The adequate filter is optional, and may be used to suppress the carrier relative to the adjacent channels power level in order to achieve the required values given in Table 1 especially at fourth or higher adjacent channel. Care should be taken not to attenuate spurious transmissions by the use of the optional filter. The adequate filter may be a cavity notch filter or a quartz notch filter.

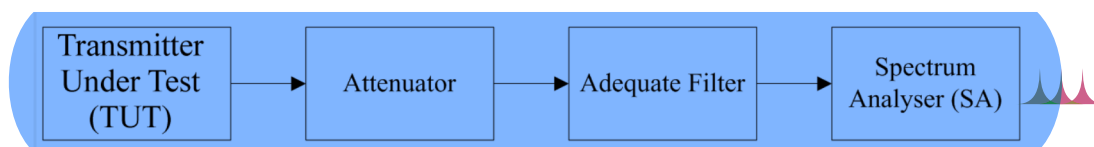

Figure 4: Second and higher adjacent channel power measurement including the optional "Adequate Filter"

4.2.1.4 Spurious emissions

4.2.1.4.1 Conducted emissions

4.2.1.4.1.1 Requirement

Unwanted emissions, including spurious and out-of-band emissions, shall be compliant with the levels shown in Table 2 and specified in Table 3.7.3.5-2 of ICAO Annex 10 [2]. The total power in any VDB harmonic or discrete signal shall not be greater than -53 dBm.

Testing for unwanted emissions in the 9 kHz to 108 MHz band shall be performed with the VDB transmitter operating at the lowest assignable channel. Testing for unwanted emissions in the 117,975 MHz to 1,7 GHz band shall be performed with the VDB transmitter operating at the highest assignable channel. The harmonics shall be measured at both the lowest and highest assignable channels.

Table 2: GBAS broadcast unwanted emissions

Frequency	Relative Power	Maximum Power
9 kHz to 150 kHz	-93 dBc (see note 3)	-55 dBm / 1 kHz
150 kHz to 30 MHz	-103 dBc (see note 3)	-55 dBm / 10 kHz
30 MHz to 106,125 MHz	-115 dBc	-57 dBm / 100 kHz
106,425 MHz	-113 dBc	-55 dBm / 100 kHz
107,225 MHz	-105 dBc	-47 dBm / 100 kHz
107,625 MHz	-101,5 dBc	-53,5 dBm / 10 kHz
107,825 MHz	-88,5 dBc	-40,5 dBm / 10 kHz
107,925 MHz	-74 dBc	-36 dBm / 1 kHz
107,9625 MHz	-71 dBc	-33 dBm / 1 kHz
107,975 MHz	-65 dBc	-27 dBm / 1 kHz
118,000 MHz	-65 dBc	-27 dBm / 1 kHz
118,0125 MHz	-71 dBc	-33 dBm / 1 kHz
118,050 MHz	-74 dBc	-36 dBm / 1 kHz
118,150 MHz	-88,5 dBc	-40,5 dBm / 10 kHz
118,350 MHz	-101,5 dBc	-53,5 dBm / 10 kHz
118,750 MHz	-105 dBc	-47 dBm / 100 kHz
119,550 MHz	-113 dBc	-55 dBm / 100 kHz
119,850 MHz to 1 GHz	-115 dBc	-57 dBm / 100 kHz
1 GHz to 1,7 GHz	-115 dBc	-47 dBm / 1 MHz
NOTE 1: The maximum unwanted emission level (absolute power) applies if the authorized transmitter power exceeds 150 W.		
NOTE 2: The relative unwanted emission level is to be computed using the same bandwidth for desired and unwanted signals. This may require conversion of the measurement for unwanted signals done using the bandwidth indicated in the maximum unwanted emission level column of this table.		
NOTE 3: This value is driven by measurement limitations. Actual performance is expected to be better.		
NOTE 4: The relationship is linear between single adjacent points designated by the adjacent channels identified above.		

4.2.1.4.1.2 Conformance

The following conformance test shall be performed to comply with the technical requirement in clause 4.2.1.4.1.1.

The following equipment is required:

- Transmitter under test (TUT).
- Spectrum analyser (SA) with power band marker function.
- Suitable attenuator to assure best measurement operation of the SA.
- Adequate filter to assure a dynamic range of the measurement system for the spurious emissions limits in excess of 10 dB more than the required.

The measurement procedure consists of the following steps:

NOTE: This test procedure is also suitable for the measurement of Adjacent Channel Power performance above the fourth adjacent channel.

- Step 1: Connect the equipment as shown in Figure 5.
- Step 2: Tune the transmitter to the test frequency 108,025 MHz.
- Step 3: Using the filter to reject the on-channel signal in order to increase the dynamic range of the measurement without overloading the spectrum analyser. Measure the frequency response of the filter and take this into account when calculating spurious measurement results.
- Step 4: Set the transmission generator to produce continuous maximum length messages and key the transmitter under test "on".

- Step 5: Adjust the spectrum analyser reference level to provide the maximum dynamic range for display and set the input attenuator to minimum required to ensure that no signal at the analyser input exceeds the maximum allowable level.
- Step 6: Measure the power level at each visible spurious signal up to 107,975 MHz using power band markers appropriate to the bandwidths specified in clause 4.2.1.4.1.1. Use the filter to reject the carrier in order to increase the dynamic range of the measurement without overloading the spectrum analyser.
- Step 7: Measure the frequency response of the filter and take this into account when presenting spurious measurement results. If a bandpass filter is used, it will need to be tuned to several measurement frequencies, covering the overall measured frequency range.
- Step 8: Check that the results do not exceed the limits specified in clause 4.2.1.4.1.1.
- Step 9: Repeat Steps 2 to 8 at the transmitter test frequency of 117,950 MHz. Measure all power levels (see Step 6) at spurious signal above 117,950 MHz

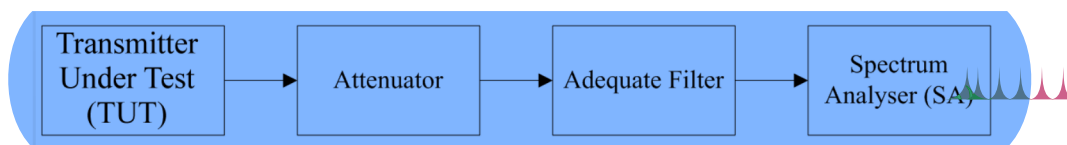

Figure 5: Conducted unwanted measurement

4.2.1.4.2 Radiated emissions - cabinet radiation

4.2.1.4.2.1 Requirement

Requirement for cabinet radiation shall be as specified in ETSI EN 300 113-1 [1], clause 7.5.4, Table 5.

4.2.1.4.2.2 Conformance

The conformance test specified in clause 7.5.3 of ETSI EN 300 113-1 [1] shall be performed to comply with the technical requirement in clause 4.2.1.4.2.1.

4.2.1.5 Intermodulation attenuation

4.2.1.5.1 Requirements

Requirement for Inter-modulation attenuation shall be as specified in ETSI EN 300 113-1 [1], clause 7.6.3.

4.2.1.5.2 Conformance

The conformance test specified in clause 7.6.2 of ETSI EN 300 113-1 [1] shall be performed to comply with the technical requirement in clause 4.2.1.5.1.

4.2.1.6 Transient behaviour of the transmitter

4.2.1.6.1 RF power rise time

4.2.1.6.1.1 Requirement

The transmitter shall ramp up to 90 % of the steady state measured output power level (see clause 4.2.1.2.1) in a time less than 190,5 μ s (two symbols) after the beginning of the burst. The transmitter shall stabilize above 90 % of the steady state measured output power level within 476,2 μ s (five symbols) after the beginning of the burst (see also ICAO Annex 10 Vol I Appendix B 3.6.3.1.4 [2]).

NOTE: The transmitter power stabilization segment consists of 5 symbols each representing 000 (2 symbols for the RF power rise time and 3 symbols for the receiver AGC stabilization).

4.2.1.6.1.2 Conformance

The following conformance test shall be performed to comply with the technical requirement in clause 4.2.1.6.1.1.

The following equipment is required:

- Transmitter under test (TUT).
- 1 PPS Reference source.
- Spectrum analyser (SA).
- Suitable attenuator to assure best measurement operation of the SA.

The measurement procedure consists of the following steps:

- Step 1: Connect the equipment as shown in Figure 6.
- Step 2: Tune the transmitter to the test frequency 108,025 MHz.
- Step 3: Key the transmitter under test "on" and modulate it with a GBAS Standard Test Message in a specific slot.
- Step 4: Adjust the attenuator in the analyser to the minimum value which does not overload the input stage of the unit.
- Step 5: Use the zero span mode of the signal analyser. Use the analyser video trigger.
- Step 6: Adjust the analyser Reference Level in order to have the "steady state" of the envelope at the top of the analyser display.
- Step 7: Repeat Steps 2 to 6 at the two remaining test frequencies:
- 112,00 MHz.
 - 117,950 MHz.
- Step 8: Check that the results do not exceed the limits specified in clause 4.2.1.6.1.1.

NOTE 1: The beginning of the burst corresponds to timeslot start time which is synchronous with the 1PPS signal.

NOTE 2: The following analyser settings can be used: RBW=10 kHz, VBW=20 kHz, SWT=5 ms, attenuation=10 dB.

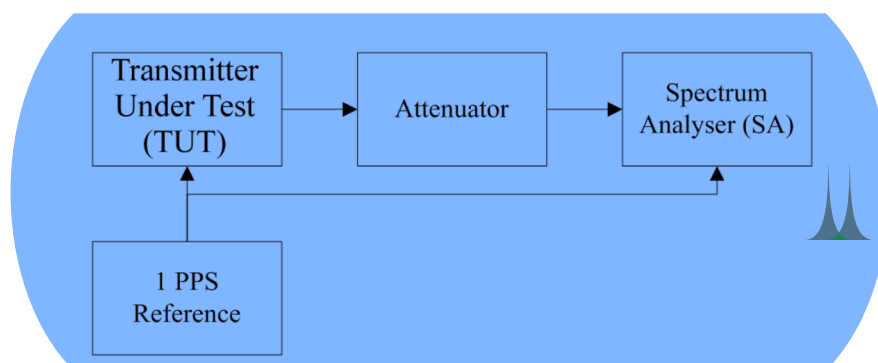

Figure 6: RF power rise and release time measurement (also applicable for RF power release time measurements and emissions in unassigned time slots measurements)

4.2.1.6.2 RF power release time

4.2.1.6.2.1 Requirement

The transmitter output power shall decay at least 30 dB below the steady state declared output power level (see clause 4.2.1.2) within 285,7 μ s (three symbols) after transmitting the final information symbol in an assigned time slot (see also ICAO Annex 10 Vol I Appendix B 3.6.3.1.5 [2]).

4.2.1.6.2.2 Conformance

The following conformance test shall be performed to comply with the technical requirement in clause 4.2.1.6.2.1.

The following equipment is required:

- Transmitter under test (TUT).
- 1 PPS Reference source.
- Spectrum analyser (SA).
- Suitable attenuator to assure best measurement operation of the SA.

The measurement procedure consists of the following steps:

Step 1: Connect the equipment as shown in Figure 6.

Step 2: Tune the transmitter to the test frequency 108,025 MHz.

Step 3: Key the transmitter under test "on" and modulate it with a GBAS Standard Test Message in a specific slot.

Step 4: Adjust the attenuator in the analyser to the minimum value which does not overload the input stage of the unit.

Step 5: Use the zero span mode of the signal analyser. Use the analyser video trigger. (Typical analyser settings are: RBW=10 kHz, VBW=20 kHz, SWT=5 ms, attenuation=10 dB).

Step 6: Adjust the analyser Reference Level in order to have the "steady state" of the envelope at the top of the analyser display.

Step 7: Repeat Steps 2 to 6 at the two remaining test frequencies:

- 112,00 MHz.
- 117,950 MHz.

Step 8: Check that the results do not exceed the limits specified in clause 4.2.1.6.2.1.

NOTE: The beginning of the burst corresponds to timeslot start time which is synchronous with the 1PPS signal.

4.2.1.7 Modulation Accuracy - Symbol constellation error

4.2.1.7.1 Requirement

The rms Error Vector Magnitude (EVM), shall be less than 6,5 % RMS.

4.2.1.7.2 Conformance

The following conformance test shall be performed to comply with the technical requirement in clause 4.2.1.7.1 (see also ICAO Annex 10 Vol I Appendix B 3.6.2.4 [2]).

The following equipment is required:

- Transmitter under test (TUT).

- Suitable attenuator to assure best measurement operation of the Vector Signal Analyser VSA.
- Vector Signal Analyser VSA.

The measurement procedure consists of the following steps:

- Step 1: Connect the equipment as shown in Figure 7.
- Step 2: Tune the transmitter to the test frequency 108,025 MHz.
- Step 3: Key the transmitter under test "on" and modulate it with a GBAS Standard Test Message in a specific slot.
- Step 4: Adjust the attenuator in the analyser to the minimum value which does not overload the input stage of the unit.
- Step 5: Key the transmitter under test "on" and modulate it with continuous maximum length messages produced by the transmission generator.
- Step 6: Record the RMS phase error at the symbol centres.
- Step 7: Repeat Steps 2 to 6 at the two remaining test frequencies:
- 112,00 MHz.
 - 117,950 MHz.
- Step 8: Check that the results do not exceed the limits specified in clause 4.2.1.7.1.

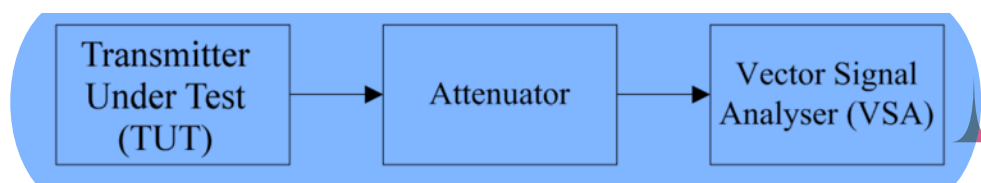

Figure 7: Modulation accuracy measurement

4.2.1.8 Emissions in unassigned time slots

4.2.1.8.1 Requirement

Under all operating conditions, the maximum power over a 25 kHz bandwidth, centred on the assigned frequency, when measured over any unassigned timeslot, shall not exceed -105 dBc referenced to the declared output power (see also ICAO Annex 10 Vol I Appendix B 3.6.2.6 [2]).

NOTE: Unlimited emissions in unassigned time slots could interfere the transmission of adjacent GBAS systems and therefore prevent the efficient frequency usage.

4.2.1.8.2 Conformance

The following conformance test shall be performed to comply with the technical requirement in clause 4.2.1.8.1.

The following equipment is required:

- Transmitter under test (TUT).
- 1 PPS Reference source.
- Spectrum analyser (SA).
- Suitable attenuator to assure best measurement operation of the SA.

The measurement procedure consists of the following steps:

- Step 1: Connect the equipment as shown in Figure 6.
- Step 2: Tune the transmitter to the test frequency 108,025 MHz.
- Step 3: Key the transmitter under test "on" and modulate it with a GBAS Standard Test Message in a specific slot.
- Step 4: Adjust the attenuator in the analyser to the minimum value which does not overload the input stage of the unit.
- Step 5: Use the zero span mode of the signal analyser. Use the analyser video trigger. (Typical analyser settings are: RBW=10 kHz, VBW=20 kHz, SWT=5 ms, attenuation=10 dB).
- Step 6: Adjust the analyser Reference Level in order to have the "steady state" of the envelope at the top of the analyser display.
- Step 7: Repeat Steps 2 to 6 at the two remaining test frequencies:
- 112,00 MHz.
 - 117,950 MHz.
- Step 8: Check that the results do not exceed the limits specified in clause 4.2.1.8.1.

NOTE: The beginning of the burst corresponds to timeslot start time which is synchronous with the 1PPS signal.

4.2.2 Receiver requirements

4.2.2.1 Applicability

All the technical requirements in clause 4.2.2 shall only be applicable for equipment containing a receiver.

4.2.2.2 Sensitivity

4.2.2.2.1 Requirements

- a) The uncorrected bit error rate (BER) of the receiver under test which is set to "uncorrected BER mode" shall be less than or equal to 10^{-4} over a dynamic range from -87 dBm to -1 dBm.
- b) The message failure rate (MFR) shall be less than or equal to one failed message per 1 000 full length (222 bytes) application data message while operating at -87 dBm.

A method for placing the receiver into the uncorrected BER mode shall be provided by manufacturers. The uncorrected BER mode is distinct from the operational mode. The uncorrected BER mode is used to measure the uncorrected BER requirement:

- The receiver shall forward each burst payload to the external BER test equipment without error detection or correction procedures.
- The test payload shall be forwarded to the external BER test equipment only if the burst was successfully detected via the standard 16 symbols synchronization sequence.

The uncorrected bit error rate (BER) is defined for GBAS test messages according to the data structure defined in clause 7.4 of Attachment D of ICAO Annex 10 [2] and shall be transmitted on an assigned time slot and shall be composed of:

- a training sequence;
- a data application payload of 222 random bytes scrambled (maximum length random message and bit scrambling);
- the Reed Solomon bytes.

4.2.2.2.2 Conformance

The following conformance test shall be performed to comply with the technical requirement in clause 4.2.2.2.1.

The following equipment is required:

- VHF Signal Generator.
- External BER test equipment.

The measurement procedure consists of the following steps:

- Step 1: Connect the equipment as shown in Figure 8 but notice that the RF combiner is not required for this test. Set the receiver under test into the uncorrected BER mode.
- Step 2: Set the desired VDB source (a VHF signal generator A) to generate an input signal to the receiver at the test frequency 108,025 MHz.
- Step 3: Modulate the desired signal with the test payload (maximum burst length of symbols) provided by the external BER test equipment. Adjust the level of the signal generator to the minimum and maximum signal level (see clause 4.2.2.2.1) at the receiver input terminals.
- Step 4: Repeat Steps 2 and 3 at the two remaining test frequencies:
- 112,00 MHz.
 - 117,950 MHz.
- Step 5: Using the external BER test equipment, determine the uncorrected BER of the demodulated data at the receiver output. Check the sensitivity requirement is achieved at all three test frequencies.

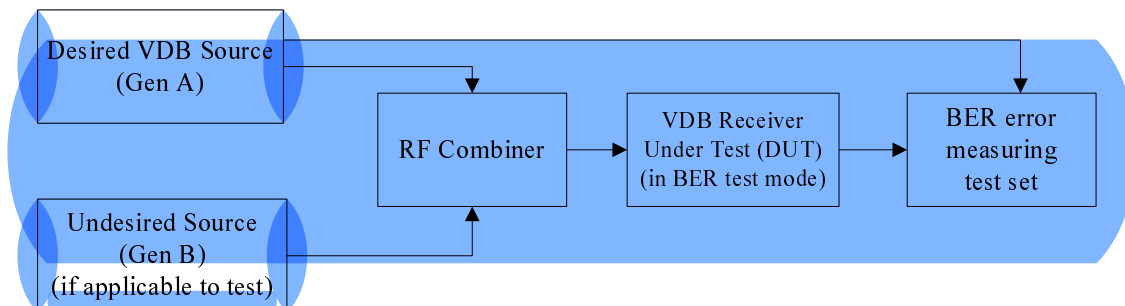

Figure 8: Receiver BER measurement

4.2.2.3 Symbol rate capture range

4.2.2.3.1 Requirements

The uncorrected bit error rate (BER) at -81 dBm input power level of the receiver under test which is set to "uncorrected BER mode" shall be less than or equal to 10^{-4} when the reference signal is subject to a symbol rate offset of ± 50 parts per million.

A method for placing the receiver into the uncorrected BER mode shall be provided by manufacturers. The uncorrected BER mode is distinct from the operational mode. The uncorrected BER mode is used to measure the uncorrected BER requirement:

- The receiver shall forward each burst payload to the external BER test equipment without error detection or correction procedures.
- The test payload shall be forwarded to the external BER test equipment only if the burst was successfully detected via the standard 16 symbols synchronization sequence.

The uncorrected bit error rate (BER) is defined for GBAS test messages according to the data structure defined in clause 7.4 of Attachment D of ICAO Annex 10 [2] and shall be transmitted on an assigned time slot and shall be composed of:

- a training sequence;
- a data application payload of 222 random bytes scrambled (maximum length random message and bit scrambling);
- the Reed Solomon bytes.

4.2.2.3.2 Conformance

The following conformance test shall be performed to comply with the technical requirement in clause 4.2.2.3.1.

The following equipment is required:

- VHF Signal Generator.
- External BER test equipment.

The measurement procedure consists of the following steps:

- Step 1: Connect the equipment as shown in Figure 8 - but notice that the RF combiner is not needed for this test. Set the receiver to the uncorrected BER mode.
- Step 2: Tune the desired VDB Source (generator A) to generate an input signal to the receiver at the test frequency 108,025 MHz. Adjust generator A to provide the reference signal level as required at the receiver input terminals.
- Step 3: Tune the VHF signal generator to the receiver channel frequency and modulate it with the test payload (maximum burst length of symbols) provided by the external BER test equipment.
- Step 4: Adjust the transmitted data clock offset of the external BER test equipment to the maximum offset specified in clause 4.2.2.3.1.
- Step 5: Apply the modulated signal to the receiver and determine the uncorrected BER of the demodulated data at the receiver output with the external BER test equipment.
- Step 6: Repeat Steps 4 and 5 after adjusting the transmitted data clock offset to the minimum offset specified in clause 4.2.2.3.1.
- Step 7: Check that the uncorrected BER requirement is achieved in all cases.

4.2.2.4 Co-channel rejection

4.2.2.4.1 Requirements

The uncorrected bit error rate (BER) at -81 dBm input power level of the receiver under test which is set to "uncorrected BER mode" shall be less than or equal to 10^{-4} in the presence of an undesired co-channel VHF data broadcast signal that is either:

- Case a) assigned to the same time slot(s) and 26 dB below the desired VHF data broadcast signal power or lower.
- Case b) assigned to a different time slot(s) and whose power level is up to 15 dBm at the receiver input.

A method for placing the receiver into the uncorrected BER mode shall be provided by manufacturers. The uncorrected BER mode is distinct from the operational mode. The uncorrected BER mode is used to measure the uncorrected BER requirement:

- The receiver shall forward each burst payload to the external BER test equipment without error detection or correction procedures.

- The test payload shall be forwarded to the external BER test equipment only if the burst was successfully detected via the standard 16 symbols synchronization sequence.

The uncorrected bit error rate (BER) is defined for GBAS test messages according to the data structure defined in clause 7.4 of Attachment D of ICAO Annex 10 [2] and shall be transmitted on an assigned time slot and shall be composed of:

- a training sequence;
- a data application payload of 222 random bytes scrambled (maximum length random message and bit scrambling);
- the Reed Solomon bytes.

4.2.2.4.2 Conformance

4.2.2.4.2.1 Co-channel rejection assigned to the same time slot(s) (see clause 4.2.2.4.1, case a)

The following conformance test shall be performed to comply with the technical requirement in clause 4.2.2.4.1.

The following equipment is required:

- 2 VHF Signal Generators.
- External BER test equipment.
- RF combiner.

The measurement procedure consists of the following steps:

- Step 1: Connect the equipment as shown in Figure 9 and set the receiver to the uncorrected BER mode.
- Step 2: Use the Desired VDB Source (named A), to generate a desired input signal to the receiver.
- Step 3: Tune the generator A to the test frequency 108,025 MHz and modulate the carrier with the test payload (maximum burst length of symbols) provided by the external BER test equipment. Adjust generator A to provide the reference signal level as required at the receiver input terminals.
- Step 4: Use the second signal generator (named B), to generate a co-channel interfering input signal to the receiver.
- Step 5: Tune the signal generator B to the receiver channel frequency and configure it to produce a narrow band FM signal with a maximum peak deviation of $\pm 5,25$ kHz. Modulate generator B with a 400 Hz sine wave. Adjust generator B to produce an interfering signal level 20 dB below the reference signal level as required at the receiver input terminals.
- Step 6: Apply the desired signal and the co-channel interfering FM modulated signal to the receiver input via the RF combiner and measure the uncorrected BER of the demodulated data at the receiver output with the external BER test equipment.
- Step 7: Repeat Steps 2 to 6 at the two remaining test frequencies:
 - 112,00 MHz.
 - 117,950 MHz.
- Step 8: Check that the uncorrected BER requirement is achieved in all cases.

NOTE: The value of 20 dB includes a 6 dB margin in order to compensate eventual lower interfering effects of a FM signal compared to a GBAS-VDB signal.

4.2.2.4.2.2 Co-channel rejection assigned to different time slot(s) (see clause 4.2.2.4.1 case b)

The following conformance test shall be performed to comply with the technical requirement in clause 4.2.2.4.1.

The following equipment is required:

- 2 VHF signal generators.
- 1 PPS Reference.
- External BER test fixture (PC with suitable software).
- RF combiner. ⚠

⚠ The measurement procedure consists of the following steps:

- Step 1: Connect the equipment as shown in Figure 9 and set the receiver to the uncorrected BER mode.
- Step 2: Adjust the Desired VDB Source (generator A), to produce an input signal to the receiver at the middle test frequency.
- Step 3: Modulate generator A on the second assignable time slot with GBAS test messages (max length) provided by the external BER test fixture (PC + Software). Adjust signal generator A to produce the reference signal level as required at the receiver input via the RF combiner.
- Step 4: Use the second generator (named B), to generate a co-channel interfering input signal (max length) to the receiver (on the first assignable time slot). Adjust the level of the generator to obtain the interfering signal level (see clause 4.2.2.4.1 case b) ⚠ at the receiver input via the RF combiner.
- Step 5: Check that the co-channel rejection requirement (defined in clause 4.2.2.4.1 case b) is achieved.

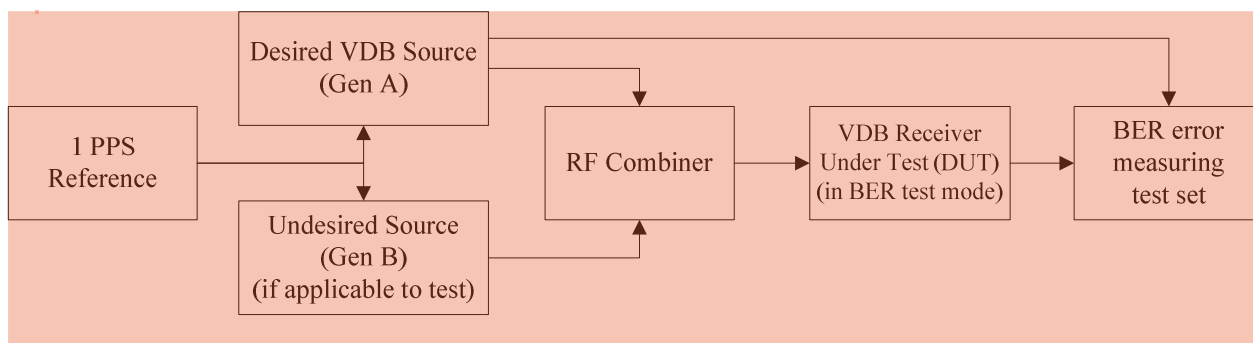

Figure 9: Time slot decoding measurement

4.2.2.5 Adjacent Channel selectivity

4.2.2.5.1 Requirements

4.2.2.5.1.1 First adjacent 25 kHz channel (± 25 kHz)

The uncorrected bit error rate (BER) at -81 dBm input power level of the receiver under test which is set to "uncorrected BER mode" shall be less than or equal to 10^{-4} in the presence of transmitted undesired signal offset by 25 kHz on either side of the desired channel that is 18 dB above the desired signal power when the undesired signal is another VHF data broadcast signal assigned to the same time slot(s).

A method for placing the receiver into the uncorrected BER mode shall be provided by manufacturers. The uncorrected BER mode is distinct from the operational mode. The uncorrected BER mode is used to measure the uncorrected BER requirement:

- ⚠ The receiver shall forward each burst payload to the external BER test equipment without error detection or correction procedures.

- The test payload shall be forwarded to the external BER test equipment only if the burst was successfully detected via the standard 16 symbols synchronization sequence.

The uncorrected bit error rate (BER) is defined for GBAS test messages according to the data structure defined in clause 7.4 of Attachment D of ICAO Annex 10 [2] and shall be transmitted on an assigned time slot and shall be composed of:

- a training sequence;
- a data application payload of 222 random bytes scrambled (maximum length random message and bit scrambling);
- the Reed Solomon bytes.

4.2.2.5.1.2 Second adjacent 25 kHz channel (± 50 kHz)

The uncorrected bit error rate (BER) at -81 dBm input power level of the receiver under test which is set to "uncorrected BER mode" shall be less than or equal to 10^{-4} in the presence of transmitted undesired signal offset by 50 kHz on either side of the desired channel that is 43 dB above the desired signal power when the undesired signal is another VHF data broadcast source assigned to the same time slot(s).

A method for placing the receiver into the uncorrected BER mode shall be provided by manufacturers. The uncorrected BER mode is distinct from the operational mode. The uncorrected BER mode is used to measure the uncorrected BER requirement:

- The receiver shall forward each burst payload to the external BER test equipment without error detection or correction procedures.
- The test payload shall be forwarded to the external BER test equipment only if the burst was successfully detected via the standard 16 symbols synchronization sequence.

The uncorrected bit error rate (BER) is defined for GBAS test messages according to the data structure defined in clause 7.4 of Attachment D of ICAO Annex 10 [2] and shall be transmitted on an assigned time slot and shall be composed of:

- a training sequence;
- a data application payload of 222 random bytes scrambled (maximum length random message and bit scrambling);
- the Reed Solomon bytes.

4.2.2.5.1.3 Third and beyond adjacent 25 kHz channels (± 75 kHz or more)

The uncorrected bit error rate (BER) at -81 dBm input power level of the receiver under test which is set to "uncorrected BER mode" shall be less than or equal to 10^{-4} in the presence of transmitted undesired signals offset by 75 kHz or more on either side of the desired channel that is 46 dB above the desired signal power when the undesired signal is another VHF data broadcast signal assigned to the same time slot(s).

The requirement shall be achieved at interfering signals at:

- the third upper and lower adjacent channels;
- the fourth upper and lower adjacent channels;
- the 8th upper and lower adjacent channels;
- the 16th upper and lower adjacent channels.

A method for placing the receiver into the uncorrected BER mode shall be provided by manufacturers. The uncorrected BER mode is distinct from the operational mode. The uncorrected BER mode is used to measure the uncorrected BER requirement:

- The receiver shall forward each burst payload to the external BER test equipment without error detection or correction procedures.
- The test payload shall be forwarded to the external BER test equipment only if the burst was successfully detected via the standard 16 symbols synchronization sequence.

The uncorrected bit error rate (BER) is defined for GBAS test messages according to the data structure defined in clause 7.4 of Attachment D of ICAO Annex 10 [2] and shall be transmitted on an assigned time slot and shall be composed of:

- a training sequence;
- a data application payload of 222 random bytes scrambled (maximum length random message and bit scrambling);
- the Reed Solomon bytes.

4.2.2.5.2 Conformance

4.2.2.5.2.1 First adjacent 25 kHz channel (± 25 kHz)

The following conformance test shall be performed to comply with the technical requirement in clause 4.2.2.5.1.1.

The following equipment is required:

- 2 VHF Signal Generators.
- External BER test equipment.
- RF combiner.

The measurement procedure consists of the following steps:

- Step 1: Connect the equipment as shown in Figure 9 and set the receiver to the uncorrected BER mode.
- Step 2: Adjust the Desired VDB Source, generator A, to produce an input signal to the receiver at the test frequency 108,025 MHz.
- Step 3: Modulate generator A with the test payload (maximum burst length of symbols) using the external BER test fixture. Adjust signal generator A to provide the reference signal level as required at the receiver input terminals.
- Step 4: Use the second VHF signal generator (named B), to generate an adjacent channel interfering input signal to the receiver.
- Step 5: Tune generator B to the first upper adjacent channel frequency. Set generator B to produce an interfering source (narrow-band FM signal to simulate a second VDB source). Apply the desired input signal and the adjacent interfering signal to the receiver input via the RF combiner.
- Step 6: Adjust the level of signal generator B until the uncorrected BER is reduced to the minimum requirement. Record the interfering signal level at the receiver input terminals.
- Step 7: Repeat Steps 5 and 6 for the lower adjacent channel.
- Step 8: Determine the ratio between the Desired and Interfering signal levels for both upper and lower adjacent channels. Record the higher of these two values.
- Step 9: Repeat Steps 4 and 8 for the two remaining test frequencies:
 - 112,00 MHz.

- 117,950 MHz.

Step 10: Check that the Adjacent Channel Rejection requirement (defined in clause 4.2.2.5.1) is achieved in all cases.

The noise sidebands of the interfering signal shall not to interfere with the desired signal in the receiver passband. The isolation offered by the RF combiner shall be sufficient to prevent intermodulation between the VHF generators.

4.2.2.5.2.2 Second and beyond adjacent 25 kHz channels (± 50 kHz or more)

The following conformance test shall be performed to comply with the technical requirement in clauses 4.2.2.5.1.2 and 4.2.2.5.1.3.

The following equipment is required:

- 2 VHF Signal Generators.
- External BER test equipment.
- RF combiner.

The measurement procedure consists of the following steps:

- Step 1: Connect the equipment as shown in Figure 9 and set the receiver to the uncorrected BER mode.
- Step 2: Adjust the Desired VDB Source, generator A, to produce an input signal to the receiver at the test frequency 108,025 MHz.
- Step 3: Modulate generator A with the test payload (maximum burst length of symbols) using the external BER test fixture. Adjust signal generator A to provide the reference signal level as required at the receiver input terminals.
- Step 4: Use the second VHF signal generator (named B), to generate an interfering input signal to the receiver.
- Step 5: Tune generator B to the second upper adjacent channel frequency related to the frequency set in generator A (see Step 3). Set generator B to produce an interfering source (narrow-band FM signal to simulate a second VDB source). Adjust the level of the signal generator B to the unmodulated interfering signal power value (also defined in clause 4.2.2.4.2.2) at the receiver input terminals.
- Step 6: Apply the wanted input signal and the unmodulated interfering signal to the receiver input via the RF combiner and determine the uncorrected BER of the demodulated data with the external BER test equipment.
- Step 7: Repeat Steps 5 and 6 for the lower second adjacent channel and the upper and lower third adjacent channels related to the frequency set in generator A (see Step 3).
- Step 8: Check that the uncorrected BER requirement is achieved in all cases.
- Step 9: Repeat Steps 5 to 8 for the remaining adjacent channel specified in the in clause 4.2.2.5.1.
- Step 10: Repeat Steps 2 to 9 at the two remaining test frequencies:
- 112,00 MHz.
 - 117,950 MHz.

The noise sidebands of the interfering signal shall not to interfere with the desired signal in the receiver passband. The isolation offered by the RF combiner shall be sufficient to prevent intermodulation between the VHF generators.

4.2.2.6 Spurious response rejection

4.2.2.6.1 Requirements

4.2.2.6.1.1 Interference Immunity

The uncorrected bit error rate (BER) at -81 dBm input power level of the receiver under test which is set to "uncorrected BER mode" shall be less than or equal to 10^{-4} in the presence of one or more signals having the frequency and total interference levels specified in Table 3 (see also ICAO Annex 10 Vol I Appendix B 3.6.8.2.2.8.2 [2]).

Table 3: Interference immunity

Frequency	Maximum level of undesired signals at the receiver input (dBm)
50 kHz up to 88 MHz	-13
88 MHz to 107,900 MHz	(see clause 4.2.2.6.1.2)
108,000 MHz to 117,975 MHz	excluded
118,000 MHz	-44
118,025 MHz	-41
118,050 MHz up to 1 660,5 MHz	-13
NOTE: The relationship is linear between single adjacent points designated by the above frequencies.	

A method for placing the receiver into the uncorrected BER mode shall be provided by manufacturers. The uncorrected BER mode is distinct from the operational mode. The uncorrected BER mode is used to measure the uncorrected BER requirement:

- The receiver shall forward each burst payload to the external BER test equipment without error detection or correction procedures.
- The test payload shall be forwarded to the external BER test equipment only if the burst was successfully detected via the standard 16 symbols synchronization sequence.

The uncorrected bit error rate (BER) is defined for GBAS test messages according to the data structure defined in clause 7.4 of Attachment D of ICAO Annex 10 [2] and shall be transmitted on an assigned time slot and shall be composed of:

- a training sequence;
- a data application payload of 222 random bytes scrambled (maximum length random message and bit scrambling);
- the Reed Solomon bytes.

4.2.2.6.1.2 FM Desensitization

The uncorrected bit error rate (BER) at -81 dBm input power level of the receiver under test which is set to "uncorrected BER mode" shall be less than or equal to 10^{-4} in the presence of VHF FM broadcast signals with signal levels as shown in Table 4.

Table 4: Desensitization frequency and power requirements that apply for VDB frequencies from 108,025 MHz to 117,975 MHz

Frequency	Maximum level of undesired signals at the receiver input (dBm)
$88 \text{ MHz} \leq f \leq 106 \text{ MHz}$	-5
107,9 MHz	-10

A method for placing the receiver into the uncorrected BER mode shall be provided by manufacturers. The uncorrected BER mode is distinct from the operational mode. The uncorrected BER mode is used to measure the uncorrected BER requirement:

- The receiver shall forward each burst payload to the external BER test equipment without error detection or correction procedures.
- The test payload shall be forwarded to the external BER test equipment only if the burst was successfully detected via the standard 16 symbols synchronization sequence.

The uncorrected bit error rate (BER) is defined for GBAS test messages according to the data structure defined in clause 7.4 of Attachment D of ICAO Annex 10 [2] and shall be transmitted on an assigned time slot and shall be composed of:

- a training sequence;
- a data application payload of 222 random bytes scrambled (maximum length random message and bit scrambling);
- the Reed Solomon bytes.

4.2.2.6.2 Conformance

The following conformance test shall be performed to comply with the technical requirement in clause 4.2.2.6.1.

The following equipment is required:

- 2 VHF Signal Generators.
- External BER test equipment.
- RF combiner.

NOTE 1: This test procedure is applicable to basic immunity to interference sources across the frequency range 50 kHz to 1 660,5 MHz but outside the VHF aeronautical band (see clause 4.2.2.6.1) and FM desensitization (see clause 4.2.2.6.1.2).

The measurement procedure consists of the following steps:

- Step 1: Connect the equipment as shown in Figure 8 and set the receiver to the uncorrected BER mode.
- Step 2: Use the Desired VDL Source (generator A), to produce an input signal of -87 dBm to the receiver at the test frequency 108,025 MHz.
- Step 3: Modulate generator A with the test payload (maximum burst length of symbols) using the external BER test equipment. Adjust signal generator A to provide the reference signal level as required at the receiver input terminals.
- Step 4: Use the second signal generator (named B), to generate one of the specified interfering signals at the receiver input.
- Step 5: Tune generator B to any frequency defined in clause 4.2.2.6.1.2. Adjust the level of generator B to provide the interfering signal level also defined in clause 4.2.2.6.1.2, at the receiver input terminals.
- Step 6: Apply the desired input signal and the interfering signal to the receiver input via the RF combiner and determine the uncorrected BER with the external BER test equipment.
- Step 7: Repeat Steps 5 and 6 for all other frequencies.
- Step 8: Repeat Steps 4 to 7 at the two remaining test frequencies:
 - 112,00 MHz.
 - 117,950 MHz.

Step 9: Check that the uncorrected BER requirement is achieved in all cases.

The noise sidebands of the interfering signal shall not interfere with the desired signal in the receiver passband. The isolation offered by the RF combiner shall be sufficient to prevent intermodulation between the VHF generators.

NOTE 2: Any interfering signal found to reduce the uncorrected BER below the minimum requirement should be investigated using a spectrum analyser connected to the combined output. This should determine whether the RF combiner/test setup is producing an on-channel signal into the receiver under test.

NOTE 3: Alternative procedures or theoretical calculation may be used to reduce the number of discrete frequencies that are tested.

NOTE 4: When testing desensitization to unwanted FM signals at 107,9 MHz, the lowest test frequency to be applied should be 108,075 MHz. The ground subsystem VDB receiver is not required to comply with the -10 dBm desensitization requirements for FM carriers above 107,7 MHz and VDB channels at 108,025 MHz or 108,050 MHz.

4.2.2.7 Spurious emissions

4.2.2.7.1 Conducted spurious emission

4.2.2.7.1.1 Requirements

When the receiver input is terminated in a resistive load equal to the nominal receiver input impedance, the level of any spurious emission appearing across the load shall not exceed -57 dBm over the frequency range of 50 kHz to 1 215 MHz, with the exception of the range of 108 MHz to 137 MHz, where it shall not exceed -64 dBm.

4.2.2.7.1.2 Conformance

The following conformance test shall be performed to comply with the technical requirement in clause 4.2.2.7.1.1.

The following equipment is required:

- Resistive load equal to the nominal input impedance of the receiver.
- Calibrated spectrum analyser to cover the frequency range defined in clause 4.2.2.7.1.1.

The measurement procedure consists of the following steps:

Step 1: Connect the RF input of the receiver of the equipment under test directly into the RF input of the spectrum analyser.

Step 2: Tune the receiver to the test frequency 108,025 MHz.

Step 3: Using the calibrated spectrum analyser, measure the power level of any spurious emissions across the matching resistive load at the input of the receiver over the frequency range defined in clause 4.2.2.7.1.1.

Step 4: Record the frequency and power level of all signals which exceed the limit specified in clause 4.2.2.7.1.1.

Step 5: Repeat Steps 2 to 4 at the two remaining test frequencies:

- 112,00 MHz.
- 117,950 MHz.

Step 6: Check that the requirements of clause 4.2.2.7.1.1 are achieved.

4.2.2.7.2 Cabinet radiation

4.2.2.7.2.1 Requirement

Requirement for cabinet radiation shall be as specified in ETSI EN 300 113-1 [1], clause 8.10.4.

4.2.2.7.2.2 Conformance

The conformance test specified in clause 8.10.3 of ETSI EN 300 113-1 [1] shall be performed to comply with the technical requirement in clause 4.2.2.7.2.1.

4.2.2.8 Out-of-band Intermodulation

4.2.2.8.1 Requirements

The aim of the following requirement is to specify the receiver linearity in order to guarantee the third order interception point (IP3) is at least 0 dBm. The uncorrected bit error rate (BER) at -81 dBm input power level of the receiver under test which is set to "uncorrected BER mode" shall be less than or equal to 10^{-4} in the presence of two interfering signals, displaced in frequency, from the desired signal.

Desired signal (Gen A):

Level: -75 dBm

Modulation: VDB

Unwanted signal (Gen B):

Level: -32 dBm

Modulation: none

Frequency: test frequency ± 1 MHz

Unwanted signal (Gen C):

Level: -32 dBm

Modulation: VDB (simulated)

Frequency: test frequency ± 2 MHz

A method for placing the receiver into the uncorrected BER mode shall be provided by manufacturers. The uncorrected BER mode is distinct from the operational mode. The uncorrected BER mode is used to measure the uncorrected BER requirement:

- The receiver shall forward each burst payload to the external BER test equipment without error detection or correction procedures.
- The test payload shall be forwarded to the external BER test equipment only if the burst was successfully detected via the standard 16 symbols synchronization sequence.

The uncorrected bit error rate (BER) is defined for GBAS test messages according to the data structure defined in clause 7.4 of Attachment D of ICAO Annex 10 [2] and shall be transmitted on an assigned time slot and shall be composed of:

- a training sequence;
- a data application payload of 222 random bytes scrambled (maximum length random message and bit scrambling);
- the Reed Solomon bytes.

4.2.2.8.2 Conformance

The following conformance test shall be performed to comply with the technical requirement in clause 4.2.2.8.2.1.

The following equipment is required:

- 3 VHF Signal Generator.
- External BER test equipment.
- RF combiner.

The measurement procedure consists of the following steps:

Step 1: Connect the equipment as shown in Figure 10.

Step 2: Use a signal generator (named Gen A), to generate the desired VDB signal to the receiver.

Step 3: Tune generator A to the test frequency 108,025 MHz and modulate the carrier with the test payload (maximum burst length of symbols) provided by the external BER test equipment. Adjust generator A to provide a level of -75 dBm at the receiver input terminals.

Step 4: Tune interfering signal generator B to a frequency 1 MHz above the selected test frequency. Set signal generator B to produce an unmodulated carrier, input to the receiver input terminals at a level of -32 dBm.

Step 5: Tune interfering signal generator C to a frequency 2 MHz above the selected test frequency. Set signal generator C to produce an interfering source (narrow-band FM signal, to simulate a second VDB source), input to the receiver input terminals at a level of -32 dBm.

Step 6: Apply the desired signal and the two interfering signals to the receiver input via the RF combiner and determine the uncorrected BER of the demodulated data at the receiver output with the external BER test equipment.

Step 7: Repeat Steps 3 to 6 for the remaining frequency combinations by retuning generators B and C.

Step 8: Repeat Steps 2 to 7 at the two remaining test frequencies:

- 112,00 MHz.
- 117,950 MHz.

Step 9: Check that the uncorrected BER requirement is achieved in every case.

NOTE 1: In the absence of the desired signal (i.e. Generator A switched "off"), it is recommended that the intermodulation products produced by any interaction between the interfering signal generators B and C, have a power level less than -105 dBm at the receiver input. Additional band-pass filters, inserted between each generator and the RF combiner, may be necessary to reduce the intermodulation product.

NOTE 2: In order to avoid intermodulation products stimulated in the desired VDB source by the two undesired sources, attenuators or circulators may be added between the desired VDB source and the RF combiner.

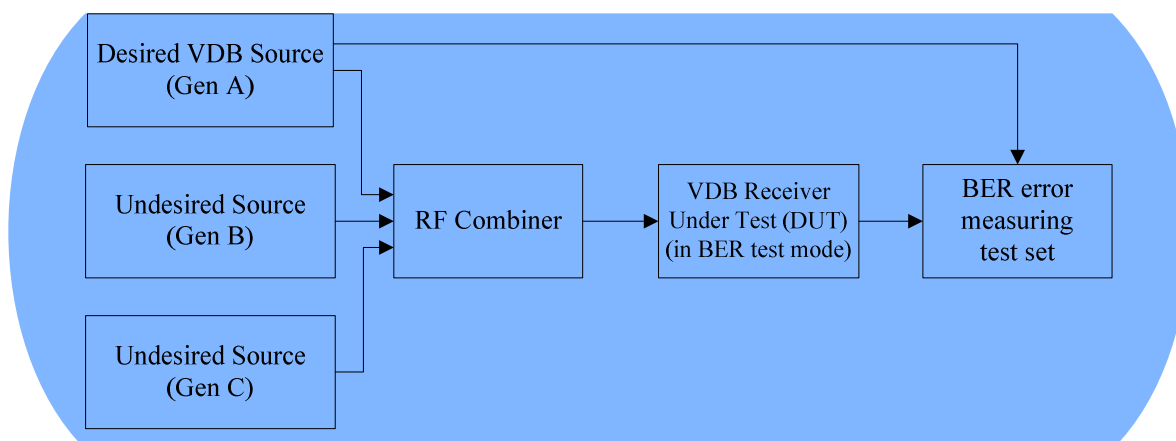

Figure 10: In band Intermodulation measurement

5 General test conditions for compliance with technical requirements

5.1 Environmental conditions for testing

5.1.0 General Requirements

Tests defined in the present document shall be carried out at representative points within the boundary limits of the declared operational environmental profile which, as a minimum, shall be that specified in the test conditions contained in the present document.

As technical performance varies subject to environmental conditions, tests shall be carried out under a sufficient variety of environmental conditions as specified in the present document to give confidence of compliance for the affected technical requirements.

5.1.1 Normal and extreme test conditions

5.1.1.0 General

Measurements shall be made under normal test conditions and also, where stated, under extreme test conditions.

5.1.1.1 Normal temperature and humidity

The normal temperature and humidity conditions for tests shall be a combination of temperature and humidity within the following ranges:

- temperature: +15 °C to +35 °C
- relative humidity: 20 % to 75 %
- atmospheric pressure between 840 to 1 085 hPa

When it is impracticable to carry out the tests under these conditions, a note to this effect, stating the ambient temperature and relative humidity during the tests, shall be added to the test report. 🏔️🏔️🏔️

5.1.1.2 Normal power sources

5.1.1.2.1 Mains voltage and frequency

The normal test voltage for equipment to be connected to the mains shall be the nominal mains voltage.

For the purpose of the present document, the nominal voltage shall be the declared voltage or any of the declared voltages for which the equipment was designed.

The frequency of the test power source shall correspond to the appropriate AC mains.

5.1.1.2.2 Other power sources

For operation from other power sources, the normal test voltage shall be that declared by the equipment manufacturer.

5.1.2 Extreme test conditions

5.1.2.1 Extreme temperatures

For tests at extreme temperatures, measurements shall be made at:

- A lower temperature of -10 °C and an upper temperature of $+55\text{ °C}$.
- A relative humidity between $+20\%$ to $+95\%$.
- An atmospheric pressure between 840 to $1\,085\text{ hPa}$.

This test shall be performed at the nominal supply voltage as defined in clause 5.1.1.2.1.

5.1.2.2 Procedure for tests at extreme temperatures

5.1.2.2.1 General

5.1.2.2.1.1 High temperature

The equipment shall be switched off during the temperature stabilizing periods.

For tests at the upper temperature on equipment designed for continuous operation, the equipment shall be placed in the test chamber and left until thermal equilibrium is reached. The equipment shall then be switched on for 30 minutes before measurements are made. Transmitters shall be operated in the highest rated power transmit condition in that 30 minutes period before measurements are made.

- Place the equipment in a chamber and heat to 55 °C ($\pm 3\text{ °C}$) and allow to stabilize for 1 hour.
- Switch on the equipment (transmitters shall be keyed).
- Switch off the equipment and allow the chamber to cool to room temperature over a 1 hour period.
- Allow time for the equipment to stabilize to normal room temperature and humidity before carrying out the next test.

5.1.2.2.2 Low temperature

The equipment shall be switched off during the temperature stabilizing periods.

For tests at the lower temperature, the equipment shall be left in the test chamber until thermal equilibrium is reached. The equipment shall then be switched on for 1 minute in the standby or receive condition before measurements are made.

- Place the equipment in a chamber and cool to -10 °C ($\pm 3\text{ °C}$) for 2 hours.

- Switch on the equipment and maintain the chamber operating temperature at -10 °C ($\pm 3\text{ °C}$).
- Switch off the equipment and allow the chamber to rise to room temperature over a 1 hour period.
- Allow time for the equipment to stabilize to normal room temperature and for moisture to disperse before carrying out the next test.

5.1.2.3 Extreme values of test power sources

Mains voltage:

- The extreme test voltages shall be $\pm 10\%$ of the value declared in clause 5.1.1.2.1.
- The frequency of the test voltage shall be the nominal frequency of the supply as declared in clause 5.1.1.2.1.
- This test shall be performed at the normal temperature and humidity as defined in clause 5.1.1.1.

5.1.2.4 Other power sources

For equipment using other power sources, or capable of being operated from a variety of power sources, the extreme test voltages shall be those agreed between the equipment manufacturer and the testing laboratory and shall be recorded in the test report.

5.1.3 Test power source

During testing, the equipment shall be supplied from a test power source capable of producing normal and extreme test voltages as specified in the clauses 5.1.1.2, 5.1.2.3 and 5.1.2.4.

The internal impedance of the test power source shall be low enough for its effect on the test results to be negligible. For the purpose of testing the power source voltage shall be measured at the input terminals of the equipment.

During testing, the power source voltages shall be maintained within a tolerance of $\pm 3\%$ relative to the voltage level at the beginning of each test. 

5.2 Interpretation of the measurement results

The interpretation of the results recorded in a test report for the measurements described in the present document shall be as follows:

- the measured value related to the corresponding limit will be used to decide whether an equipment meets the requirements of the present document;
- the value of the measurement uncertainty for the measurement of each parameter shall be included in the test report;
- the recorded value of the measurement uncertainty shall be, for each measurement, equal to or lower than the figures in Tables 5 and 6.

For the test methods, according to the present document, the measurement uncertainty figures shall be calculated and shall correspond to an expansion factor (coverage factor) $k = 1,96$ or $k = 2$ (which provide confidence levels of respectively 95 % and 95,45 % in the case where the distributions characterizing the actual measurement uncertainties are normal (Gaussian)). Principles for the calculation of measurement uncertainty are contained in ETSI TR 100 028 [i.3] and [i.4], in particular in Annex D of the ETSI TR 100 028-2 [i.4].

Tables 5 and 6 are based on such expansion factors.

Table 5: Transmitter measurement uncertainty: maximum values

Measurement uncertainties	Maximum values
Frequency error	$\pm 1 \times 10^{-7}$
Transmitter power (normal and extreme test conditions)	$\pm 0,75$ dB
Adjacent channel power	$\pm 2,5$ dB
Conducted spurious emissions: below 1 GHz	± 3 dB
between 1 GHz and 4 GHz	± 6 dB
Cabinet radiation	± 6 dB
Intermodulation attenuation	± 3 dB
Power rise time	± 20 % of the limits values
Power release time	± 20 % of the limits values
Modulation Accuracy - Symbol constellation error	EVM (rms) ± 2 %
Emission in unassigned time slots	± 3 dB

Table 6: Receiver measurement uncertainty: maximum values

Measurement uncertainties	Maximum values
Sensitivity	± 3 dB
Symbol rate capture range	$\pm 5 \times 10^{-6}$
Co-channel interference	± 3 dB
Adjacent channel rejection	± 4 dB
Interference Immunity	± 3 dB
FM desensitization	± 3 dB
Conducted spurious emissions: below 1 GHz	± 3 dB
between 1 GHz and 4 GHz	± 6 dB
Cabinet radiation	± 6 dB
Out-of-band Intermodulation	± 3 dB

Annex A (normative): Relationship between the present document and the essential requirements of Directive 2014/53/EU

The present document has been prepared under the Commission's standardisation request C(2015) 5376 final [1.7] to provide one voluntary means of conforming to the essential requirements of Directive 2014/53/EU on the harmonisation of the laws of the Member States relating to the making available on the market of radio equipment and repealing Directive 1999/5/EC [i.1].

Once the present document is cited in the Official Journal of the European Union under that Directive, compliance with the normative clauses of the present document given in Table A.1 confers, within the limits of the scope of the present document, a presumption of conformity with the corresponding essential requirements of that Directive, and associated EFTA regulations.

Table A.1: Relationship between the present document and the essential requirements of Directive 2014/53/EU

Harmonised Standard ETSI EN 303 084				
The following requirements are relevant to the presumption of conformity under the article 3.2 of Directive 2014/53/EU [i.1]				
Requirement			Requirement Conditionality	
No	Description	Reference: Clause No	U/C	Condition
1	Frequency error	4.2.1.1	C	Only applicable for equipment containing a transmitter
2	Transmitter power	4.2.1.2	C	Only applicable for equipment containing a transmitter
3	Adjacent channel power	4.2.1.3	C	Only applicable for equipment containing a transmitter
4	Spurious emissions - Conducted emissions	4.2.1.4.1	C	Only applicable for equipment containing a transmitter
5	Spurious emissions - Radiated emissions - cabinet radiation	4.2.1.4.2	C	Only applicable for equipment containing a transmitter
6	Intermodulation attenuation	4.2.1.5	C	Only applicable for equipment containing a transmitter
7	Transient behaviour of the transmitter - RF power rise time	4.2.1.6.1	C	Only applicable for equipment containing a transmitter
8	Transient behaviour of the transmitter - RF power release time	4.2.1.6.2	C	Only applicable for equipment containing a transmitter
9	Modulation Accuracy - Symbol constellation error	4.2.1.7	C	Only applicable for equipment containing a transmitter
10	Emissions in unassigned time slots	4.2.1.8	C	Only applicable for equipment containing a transmitter
11	Sensitivity	4.2.2.2	C	Only applicable for equipment containing a receiver
12	Symbol rate capture range	4.2.2.3	C	Only applicable for equipment containing a receiver
13	Co-channel rejection	4.2.2.4	C	Only applicable for equipment containing a receiver
14	Adjacent Channel selectivity	4.2.2.5	C	Only applicable for equipment containing a receiver
15	Spurious response rejection	4.2.2.6	C	Only applicable for equipment containing a receiver
16	Spurious emissions - Conducted spurious emission	4.2.2.7.1	C	Only applicable for equipment containing a receiver
17	Spurious emissions - Cabinet radiation	4.2.2.7.2	C	Only applicable for equipment containing a receiver
18	Out-of-band Intermodulation	4.2.2.8	C	Only applicable for equipment containing a receiver

Key to columns:**Requirement:**

No A unique identifier for one row of the table which may be used to identify a requirement.

Description A textual reference to the requirement.

Clause Number Identification of clause(s) defining the requirement in the present document unless another document is referenced explicitly.

Requirement Conditionality:

U/C Indicates whether the requirement shall be unconditionally applicable (U) or is conditional upon the manufacturer's claimed functionality of the equipment (C).

Condition Explains the conditions when the requirement shall or shall not be applicable for a requirement which is classified "conditional".

Presumption of conformity stays valid only as long as a reference to the present document is maintained in the list published in the Official Journal of the European Union. Users of the present document should consult frequently the latest list published in the Official Journal of the European Union.

Other Union legislation may be applicable to the product(s) falling within the scope of the present document.

Annex B (informative): Bibliography

EUROCAE ED-114A: "Minimum operational performance specification for global navigation satellite ground based augmentation system equipment to support category I operations".

History

Document history		
V1.1.1	May 2013	Publication
V2.1.0	August 2015	EN Approval Procedure AP 20151203: 2015-08-05 to 2015-12-03
V2.1.0	June 2016	Vote V 20160802: 2016-06-03 to 2016-08-02
V2.1.1	August 2016	Publication