

ETSI EN 302 186 V2.2.1 (2021-05)



**Satellite Earth Stations and Systems (SES);
~~Harmonised Standard for satellite~~ Satellite mobile
_ Aircraft Earth Stations (AESs)
operating in the 11/12/14_ GHz frequency bands;
covering the essential requirements
of ~~article 3.2 of the Directive 2014/53/EU~~
Harmonised Standard for access to radio spectrum**

ReferenceREN/SES-00435

Keywordsaeronautical, air interface, AMSS, earth station,
FSS, GSO, mobile, MSS, regulation, satellite**ETSI**650 Route des Lucioles
F-06921 Sophia Antipolis Cedex - FRANCE

Tel.: +33 4 92 94 42 00 Fax: +33 4 93 65 47 16

Siret N° 348 623 562 00017 - APE 7112B
Association à but non lucratif enregistrée à la
Sous-Préfecture de Grasse (06) N° w061004871

Important notice

The present document can be downloaded from:
<http://www.etsi.org/standards-search>

The present document may be made available in electronic versions and/or in print. The content of any electronic and/or print versions of the present document shall not be modified without the prior written authorization of ETSI. In case of any existing or perceived difference in contents between such versions and/or in print, the prevailing version of an ETSI deliverable is the one made publicly available in PDF format at www.etsi.org/deliver.

Users of the present document should be aware that the document may be subject to revision or change of status. Information on the current status of this and other ETSI documents is available at <https://portal.etsi.org/TB/ETSIDeliverableStatus.aspx>

If you find errors in the present document, please send your comment to one of the following services:
<https://portal.etsi.org/People/CommitteeSupportStaff.aspx>

Notice of disclaimer & limitation of liability

The information provided in the present deliverable is directed solely to professionals who have the appropriate degree of experience to understand and interpret its content in accordance with generally accepted engineering or other professional standard and applicable regulations.

No recommendation as to products and services or vendors is made or should be implied.

In no event shall ETSI be held liable for loss of profits or any other incidental or consequential damages.

Any software contained in this deliverable is provided "AS IS" with no warranties, express or implied, including but not limited to, the warranties of merchantability, fitness for a particular purpose and non-infringement of intellectual property rights and ETSI shall not be held liable in any event for any damages whatsoever (including, without limitation, damages for loss of profits, business interruption, loss of information, or any other pecuniary loss) arising out of or related to the use of or inability to use the software.

Copyright Notification

No part may be reproduced or utilized in any form or by any means, electronic or mechanical, including photocopying and microfilm except as authorized by written permission of ETSI.

The content of the PDF version shall not be modified without the written authorization of ETSI.
The copyright and the foregoing restriction extend to reproduction in all media.

© ETSI 2021.
All rights reserved.

Contents

Intellectual Property Rights	7
Foreword.....	7
Modal verbs terminology	8
Introduction	8
1 Scope.....	9
2 References	10
2.1 Normative references	10
2.2 Informative references	11
3 Definition of terms, symbols and abbreviations.....	12
3.1 Terms	12
3.2 Symbols	17
3.3 Abbreviations.....	17
4 Technical requirement specifications.....	18
4.1 General.....	18
4.1.0 Introduction	18
4.1.1 Environmental profile	19
4.2 Conformance requirements	19
4.2.1 General	19
4.2.2 Off-axis spurious radiation.....	19
4.2.2.1 Justification.....	19
4.2.2.2 Specification	19
4.2.2.3 Conformance tests	21
4.2.3 On-axis spurious radiation	21
4.2.3.1 Justification.....	21
4.2.3.2 Specification	21
4.2.3.2.1 "Carrier-on" state	21
4.2.3.2.2 "Carrier-off" state and "transmission disabled" state	22
4.2.3.3 Conformance tests	22
4.2.4 Off-axis EIRP emissions density in the nominated bandwidth for 14 GHz AES and the power flux-density resulting from the 13 GHz AES towards any location in the geostationary-satellite orbit	22
4.2.4.1 Justification.....	22
4.2.4.2 Specification	22
4.2.4.2.1 14 GHz AES	22
4.2.4.2.2 13 GHz AES	23
4.2.4.3 Conformance tests	23
4.2.5 Control and Monitoring Functions (CMFs)	23
4.2.5.0 General	23
4.2.5.1 Processor monitoring.....	24
4.2.5.1.1 Justification	24
4.2.5.1.2 Specification	24
4.2.5.1.3 Conformance tests.....	25
4.2.5.2 Transmit subsystem monitoring	25
4.2.5.2.1 Justification	25
4.2.5.2.2 Specification	25
4.2.5.2.3 Conformance tests.....	25
4.2.5.3 Power-on/Reset.....	25
4.2.5.3.1 Justification	25
4.2.5.3.2 Specification	25
4.2.5.3.3 Conformance tests.....	25
4.2.5.4 Control Channel (CC) reception.....	25
4.2.5.4.1 Justification	25
4.2.5.4.2 Specification	25
4.2.5.4.3 Conformance tests.....	25
4.2.5.5 Network control commands.....	26

4.2.5.5.1	Justification	26
4.2.5.5.2	Specification	26
4.2.5.5.3	Conformance tests	26
4.2.5.6	Initial burst transmission	26
4.2.5.6.1	General	26
4.2.5.6.2	Specification	26
4.2.5.6.3	Conformance tests	27
4.2.6	Power Flux Density at the surface of the earth	27
4.2.6.0	General	27
4.2.6.1	14 GHz AES	27
4.2.6.1.1	Power flux density limits in the 14,00 GHz to 14,50 GHz frequency band	27
4.2.6.2	13 GHz AES	29
4.2.6.2.0	General	29
4.2.6.2.1	Justification	29
4.2.6.2.2	Specification	30
4.2.6.2.3	Conformance tests	30
4.2.7	Receive antenna off-axis gain pattern	30
4.2.7.1	Justification	30
4.2.7.2	Specification	30
4.2.7.3	Conformance tests	30
4.2.8	Blocking performance	31
4.2.8.1	Justification	31
4.2.8.2	Specification	31
4.2.8.3	Conformance tests	31
4.2.9	Adjacent signal selectivity	31
4.2.9.1	Justification	31
4.2.9.2	Specification	31
4.2.9.3	Conformance tests	32
4.2.10	Image frequency rejection	32
4.2.10.1	Justification	32
4.2.10.2	Specification	32
4.2.10.3	Conformance tests	32
5	Testing for compliance with technical requirements	32
5.1	Environmental conditions for testing	32
5.2	Nominated Bandwidth	32
6	Test methods	33
6.0	General	33
6.1	Off-axis spurious radiation	34
6.1.1	Test method	34
6.1.1.0	Introduction	34
6.1.1.1	Up to 1 000 MHz (see clause 4.2.2.2, table 2)	34
6.1.1.1.1	Test site	34
6.1.1.1.2	Measuring receivers	35
6.1.1.1.3	Procedure	35
6.1.1.2	Above 1 000 MHz (see clause 4.2.2.2, tables 3 and 4)	35
6.1.1.2.0	General	35
6.1.1.2.1	Identification of the significant frequencies of spurious radiation	35
6.1.1.2.2	Measurement of radiated power levels of identified spurious radiation	36
6.2	On-axis spurious radiation	37
6.2.1	Test method	37
6.2.1.1	Void	37
6.2.1.2	Method of measurement	37
6.2.1.2.1	General	37
6.2.1.2.2	Method of measurement at the antenna flange	37
6.2.1.2.3	Method of measurement with a test antenna	38
6.3	Off-axis EIRP emissions density in the nominated bandwidth for 14 GHz AES and the power flux- density resulting from the 13 GHz AES towards any location in the geostationary-satellite orbit	39
6.3.1	14 GHz AES	39
6.3.1.1	General	39
6.3.1.2	rms antenna pointing accuracy	40

6.3.1.2.1	Method of measurement	40
6.3.1.3	Measurement of the off-axis EIRP without the antenna	41
6.3.1.3.1	Transmitter output power density	41
6.3.1.3.2	Antenna transmit gain	41
6.3.1.3.3	Antenna transmit radiation patterns	43
6.3.1.3.4	Computation of results	44
6.3.1.4	Measurement of the off-axis EIRP with the antenna	44
6.3.1.4.1	General	44
6.3.1.4.2	Maximum EIRP density per 40 kHz ratio relative to the EIRP	44
6.3.1.4.3	Maximum on-axis EIRP	45
6.3.1.4.4	Antenna transmit radiation patterns	47
6.3.1.4.5	Computation of results	49
6.3.2	13 GHz AES	49
6.3.2.1	General	49
6.4	Power Flux Density Test.....	49
6.4.1	14 GHz AES.....	49
6.4.1.1	General	49
6.4.1.2	Verification of specification 1: Mode of PFD limitation	50
6.4.1.3	Verification of specification 2: Location where to limit the PFD.....	50
6.4.1.4	Verification of specification 3: PFD limitation	51
6.4.1.4.1	Measurement of the antenna radiation pattern below the aircraft fuselage	51
6.4.1.4.2	Measurement of on-axis EIRP as a function of altitude.....	52
6.4.1.4.3	Computation of the power flux density at the surface of the Earth.....	53
6.4.1.5	Verification of specification 4: Fault conditions	54
6.4.1.5.1	Test Arrangement.....	54
6.4.1.5.2	Test method.....	54
6.4.2	13 GHz AES.....	55
6.4.2.1	Test Method.....	55
6.5	Control and monitoring.....	55
6.5.0	General	55
6.5.1	Test arrangement	55
6.5.2	Processor monitoring.....	56
6.5.2.1	Test method	56
6.5.3	Transmit subsystem monitoring	56
6.5.3.1	Test method	56
6.5.4	Power-on/Reset	57
6.5.4.1	Test method	57
6.5.5	Control Channel (CC) reception.....	57
6.5.5.1	Test method	57
6.5.6	Network control commands	58
6.5.6.1	Test method	58
6.5.7	Initial burst transmission	59
6.5.7.1	Test method	59
6.6	Receive antenna off-axis gain pattern	60
6.6.1	Test method.....	60
6.6.1.1	Test site.....	60
6.6.1.2	Method of measurement	60
6.6.1.3	Computation	61
6.7	Blocking performance.....	61
6.7.1	General.....	61
6.7.2	Test method.....	61
6.8	Adjacent signal selectivity	62
6.8.0	General	62
6.8.1	Test method.....	62
Annex A (informative):	Relationship between the present document and the essential requirements of Directive 2014/53/EU	63
Annex B (normative):	Environmental conditions	66
B.1	General	66
B.2	Environmental conformance requirements	66

B.3 Environmental test conditions.....	66
Annex C (informative): Maximum Measurement Uncertainty.....	68
Annex D (informative): Applicability of parameters given in ETSI EG 203 336	69
Annex E (informative): Bibliography.....	71
History	72

Intellectual Property Rights

Essential patents

IPRs essential or potentially essential to normative deliverables may have been declared to ETSI. The information declarations pertaining to these essential IPRs, if any, ~~is~~ are publicly available for **ETSI members and non-members**, and can be found in ETSI SR 000 314: "*Intellectual Property Rights (IPRs); Essential, or potentially Essential, IPRs notified to ETSI in respect of ETSI standards*", which is available from the ETSI Secretariat. Latest updates are available on the ETSI Web server (<https://ipr.etsi.org/>).

Pursuant to the ETSI Directives including the ETSI IPR Policy, no investigation regarding the essentiality of IPRs, including IPR searches, has been carried out by ETSI. No guarantee can be given as to the existence of other IPRs not referenced in ETSI SR 000 314 (or the updates on the ETSI Web server) which are, or may be, or may become, essential to the present document.

Trademarks

The present document may include trademarks and/or tradenames which are asserted and/or registered by their owners. ETSI claims no ownership of these except for any which are indicated as being the property of ETSI, and conveys no right to use or reproduce any trademark and/or tradename. Mention of those trademarks in the present document does not constitute an endorsement by ETSI of products, services or organizations associated with those trademarks.

DECT™, PLUGTESTS™, UMTS™ and the ETSI logo are trademarks of ETSI registered for the benefit of its Members. 3GPP™ and LTE™ are trademarks of ETSI registered for the benefit of its Members and of the 3GPP Organizational Partners. oneM2M™ logo is a trademark of ETSI registered for the benefit of its Members and of the oneM2M Partners. GSM® and the GSM logo are trademarks registered and owned by the GSM Association.

Foreword

This Harmonised European Standard (EN) has been produced by ETSI Technical Committee Satellite Earth Stations and Systems (SES).

The present document has been prepared under the Commission's standardisation request C(2015) 5376 final [i.2] to provide one voluntary means of conforming to the essential requirements of Directive 2014/53/EU on the harmonisation of the laws of the Member States relating to the making available on the market of radio equipment and repealing Directive 1999/5/EC [i.7].

Once the present document is cited in the Official Journal of the European Union under that Directive, compliance with the normative clauses of the present document given in table A.1 confers, within the limits of the scope of the present document, a presumption of conformity with the corresponding essential requirements of that Directive, and associated EFTA regulations.

National transposition dates

Date of adoption of this EN:	<u>26 April 2021</u>
Date of latest announcement of this EN (doa):	31 <u>July 2021</u>
Date of latest publication of new National Standard or endorsement of this EN (dop/e):	<u>31 January 2022</u>
Date of withdrawal of any conflicting National Standard (dow):	<u>31 January 2023</u>

Modal verbs terminology

In the present document "**shall**", "**shall not**", "**should**", "**should not**", "**may**", "**need not**", "**will**", "**will not**", "**can**" and "**cannot**" are to be interpreted as described in clause 3.2 of the [ETSI Drafting Rules](#) (Verbal forms for the expression of provisions).

"**must**" and "**must not**" are **NOT** allowed in ETSI deliverables except when used in direct citation.

Introduction

The present document is part of a set of standards developed by ETSI and is designed to fit in a modular structure to cover all radio equipment within the scope of the Directive 2014/53/EU [6], [7]. Each standard is a module in the structure. The modular structure is shown in ETSI EG 201 399 [i.1].

The requirements have been selected to ensure an adequate level of compatibility with other radio services.

The present document may not cover those cases where a potential source of interference which is producing individually repeated transient phenomena or a continuous phenomenon is present, e.g. a radar or broadcast site in the near vicinity. In such a case it may be necessary to use special protection applied to either the source of interference, or the interfered part or both.

The present document does not contain any requirement, recommendation or information about the installation of the AES on aircraft.

The determination of the parameters of the AES using a given ~~GeoStationary Orbiting~~ Geostationary Satellite Orbit (GSO) satellite for the protection of the spectrum allocated to that satellite, is considered to be under the responsibility of the satellite operator or the satellite network operators.

1 Scope

The present document specifies certain minimum technical performance requirements of Aircraft Earth Station (AES) equipment with both transmit and receive capabilities for provision of aeronautical mobile satellite service, in the frequency bands given in table 1.

Table 1: Frequency bands for the AES equipment specified in the present document

Mode of Operation	Frequency Band
AES transmit	14,00 GHz to 14,50 GHz
AES receive/transmit	10,70/12,75 GHz to 11,70/13,25 GHz
AES receive	12,50/10,70 GHz to 12,75 GHz
NOTE: The AESs are operating in one or more frequency ranges of the Fixed and Mobile Satellite Services.	

The AES has the following characteristics:

- These AESs are equipment for installation on aircraft.
- The AESs transmit in the 14,00 GHz to 14,50 GHz band receive within the range from 10,70 GHz to 12,75 GHz ("14 GHz"), referred to as "14 GHz AES" in the present document, are operating in one or more frequency ranges of the Fixed-Satellite Service and Mobile-Satellite Service.
- The AESs transmit in the 12,75 GHz to 13,25 GHz band receive within the range from 10,70 GHz to 12,75 GHz ("13 GHz"), referred to as "13 GHz AES" in the present document, are operating in one or more frequency ranges of the Fixed-Satellite Service.

NOTE 1: When the term "AES" used in the present document without stating 13 GHz AES or 14 GHz AES, it is a reference to both 14 GHz AES and 13 GHz AES.

- The AES could consist of a number of modules from the antenna subsystem to the user interfaces.
- The AES uses linear polarization.
- The AES system uses digital modulation.
- The 14 GHz AES operates through a GSO satellite at least 3° away from any other geostationary satellite operating in the same frequency band and covering the same area.
- The 13 GHz AES operates with a GSO satellite network whose frequency assignments are from the List of Appendix 30B of the Radio Regulations.
- The antenna of the AES is directional, with means of tracking the satellites, which can be achieved by using either an active phase array or reflective type configuration.
- These AESs are operating as part of a satellite network used for the distribution and/or exchange of information between users.
- These AESs are controlled and monitored by a Network Control Facility (NCF). The NCF is outside the scope of the present document.
- When on the ground, the 14 GHz AES does not transmit at elevation angles below $7^{\circ}7'$ with respect to the local horizontal plane, except at locations where transmissions below $7^{\circ}7'$ are permitted by the local Administration; (the minimum elevation angle is also limited as per clause 4.2).

The technical requirements in the present document are in two major categories:

- **emission limits:** to protect other radio services and systems from harmful interference generated by the AES in normal use;
- **AES Control and Monitoring Functions (CMF/CMFs):** to protect other radio services and systems from unwanted transmissions from the AES. The CMF in each AES is capable of answering to commands from the Network Control Facility (NCF) for its supporting satellite network.

The present document applies to the AESs with their ancillary equipment and its various ports, and when operated within the boundary limits of the operational environmental profile ~~declared~~specified by the manufacturer.

The technical requirements for the 14 GHz AES in regard to the Power Flux Density (PFD) limits to protect Fixed Service (FS) and Radio Astronomy Service (RAS) are based on annexes B and C of Recommendation ITU-R M.1643-~~[5]~~ and ECC Report 26 ~~[i.4.i.4]~~. Furthermore, in relation to the protection of the Fixed Satellite Service (FSS) the technical requirements of the AES take into account annex A of Recommendation ITU-R M.1643 [5].

The technical requirements for the 13 GHz AES in regards to the PFD limits on earth for the protection of FS are based on the ECC Decision (19)04 [6].

The present document is intended to cover the provisions of Directive 2014/53/EU ~~[i.7]~~ (RE Directive) article 3.2, which states that "... *radio equipment shall be so constructed that it both effectively and supports the use of radio spectrum allocated in order to avoid harmful interference*".

NOTE 2: The relationship between the present document and essential requirements of article 3.2 of Directive 2014/53/EU [i.7] is given in annex A.

In addition to the present document, other ENs that specify technical requirements in respect of essential requirements of other parts of article 3 of the RE Directive ~~[i.7]~~ may apply to equipment within the scope of the present document.

NOTE 3: A list of such ENs is included on the web site at:
~~http://www.newapproach.org~~https://ec.europa.eu/growth/single-market/european-standards/harmonised-standards/red_en.

The present document does not cover equipment compliance with relevant civil aviation regulations. In this respect, an AES, for its installation and operation on board an aircraft is subject to additional national or international civil aviation airworthiness certification requirements, for example to EUROCAE ED-~~14D~~14 [4].

2 References

2.1 Normative references

References are either specific (identified by date of publication and/or edition number or version number) or non-specific. For specific references, only the cited version applies. For non-specific references, the latest version of the referenced document (including any amendments) applies.

Referenced documents which are not found to be publicly available in the expected location might be found at ~~http~~<https://docbox.etsi.org/Reference>.

NOTE: While any hyperlinks included in this clause were valid at the time of publication, ETSI cannot guarantee their long term validity.

The following referenced documents are necessary for the application of the present document.

- [1] Void.
- [2] CISPR 16-1 ~~(2003) (all sub parts)~~-1:2019: "Specification for radio disturbance and immunity measuring apparatus and methods; - Part 1-1: Radio disturbance and immunity measuring apparatus" - Measuring apparatus.
- [3] IEEE STD 149~~TM~~ ~~(TM-1979)~~: "IEEE Standard Test Procedures for Antennas".
- [4] EUROCAE ED-~~14D~~ ~~(1997) Change 1 (2000), Change 2 (2001) and Change 3 (2002)~~14 (2015) (Equivalent to RTCA DO-160D): "Environmental Conditions and Test Procedures for Airborne Equipment".
- [5] Recommendation ITU-R M.1643 ~~(06-2003)~~: "Technical and operational requirements for aircraft earth stations of aeronautical mobile-satellite service including those using fixed-satellite service network transponders in the band 14-14.5 GHz (Earth-to-space)".

- [6] ~~Directive 2014/53/EU of the European Parliament and of the Council of 16 April 2014 on the harmonisation of the laws of the Member States relating to the making available on the market of radio equipment and repealing Directive 1999/5/EC (RE Directive).~~
- [1] CEPT ECC Decision (19)04 (03-2020): "The harmonised use of spectrum, free circulation and use of earth stations on-board aircraft operating with GSO FSS networks and NGSO FSS systems in the frequency bands 12.75-13.25 GHz (Earth-to-space) and 10.7-12.75 GHz (space-to-Earth)".
- [7] ETSI ETS 300 457 (Edition 1) (11-1995): "Satellite Earth Stations and Systems (SES): Test methods for Television Receive Only (TVRO) operating in the 11/12 GHz frequency bands".

2.2 Informative references

References are either specific (identified by date of publication and/or edition number or version number) or non-specific. For specific references, only the cited version applies. For non-specific references, the latest version of the referenced document (including any amendments) applies.

NOTE: While any hyperlinks included in this clause were valid at the time of publication, ETSI cannot guarantee their long term validity.

The following referenced documents are not necessary for the application of the present document but they assist the user with regard to a particular subject area.

- [i.1] ETSI EG 201 399: "Electromagnetic compatibility and Radio spectrum Matters (ERM); A guide to the production of Harmonized Standards for application under the Radio & Telecommunication Terminal Equipment Directive 1999/5/EC (R&TTE) and a first guide on the impact of the Radio Equipment Directive 2014/53/EU (RED) on Harmonized Standards".
- [i.2] Commission Implementing Decision C(2015) 5376 final of 4.8.2015 on a standardisation request to the European Committee for Electrotechnical Standardisation and to the European Telecommunications Standards Institute as regards radio equipment in support of Directive_2014/53/EU of the European Parliament and of the Council.
- [i.3] Recommendation ITU-R S.524-79: "Maximum permissible levels of off-axis e.i.r.p. density from earth stations in geostationary-satellite orbit networks operating in the fixed-satellite service transmitting in the 6 GHz, 13 GHz, 14 GHz and 30 GHz frequency bands".
- [i.4] ECC Report 26-~~(02-2003)~~: "The compatibility & sharing of the aeronautical mobile satellite service with existing services in the band 14,00 to 14,50 ~~GHz~~GHz Molde", ~~February 2003~~.
- [i.5] ITU Radio Regulations ~~articles (2012)-2020~~.
- [i.6] ISO 7137 (1995): "Aircraft - Environmental conditions and test procedures for airborne equipment".

~~3 Definitions, symbols and abbreviations~~

~~3.1 Definitions~~

- [i.7] Directive 2014/53/EU of the European Parliament and of the Council of 16 April 2014 on the harmonisation of the laws of the Member States relating to the making available on the market of radio equipment and repealing Directive 1999/5/EC (RE Directive).
- [i.8] Recommendation ITU-R S.728-1: "Maximum permissible level of off-axis e.i.r.p. density from very small aperture terminals (VSATs)".
- [i.9] ETSI EG 203 336 (V1.2.1): "Electromagnetic compatibility and Radio spectrum Matters (ERM); Guide for the selection of technical parameters for the production of Harmonised Standards covering article 3.1(b) and article 3.2 of Directive 2014/53/EU".

3 Definition of terms, symbols and abbreviations

3.1 Terms

For the purposes of the present document, the terms ~~and definitions~~ given in the Directive 2014/53/EU [1.7] and the following apply:

Figure 1a: Void

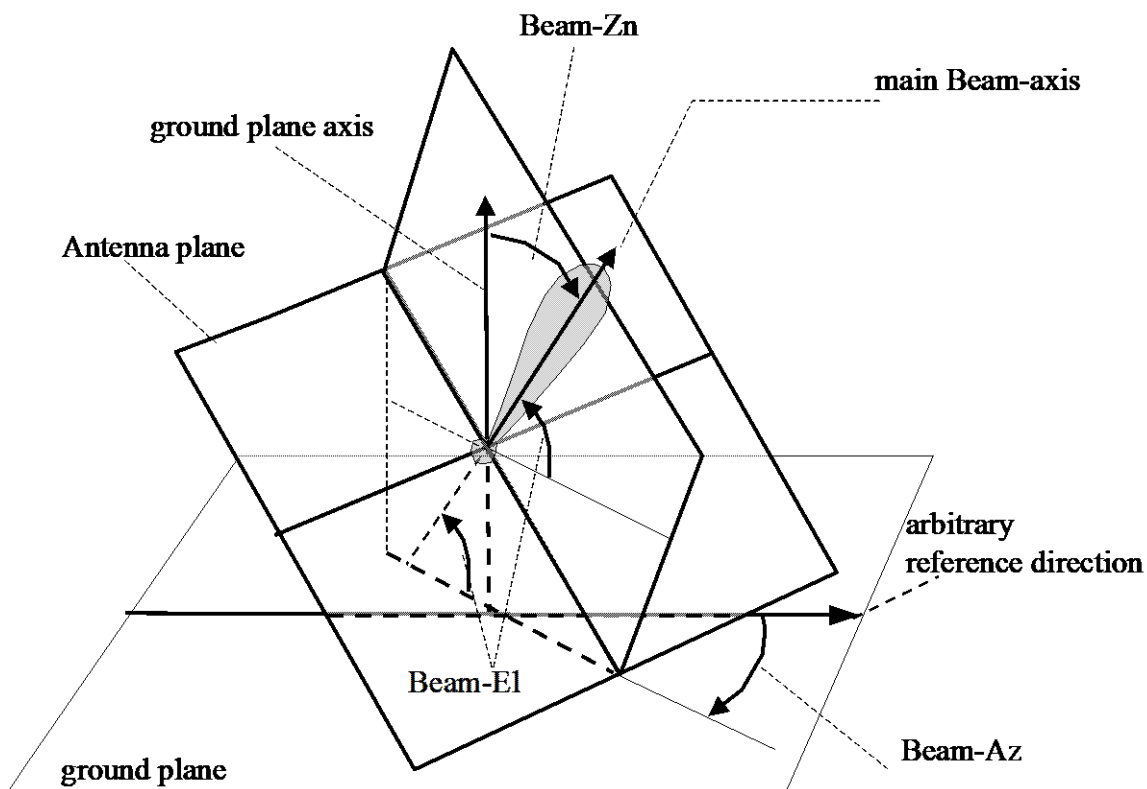
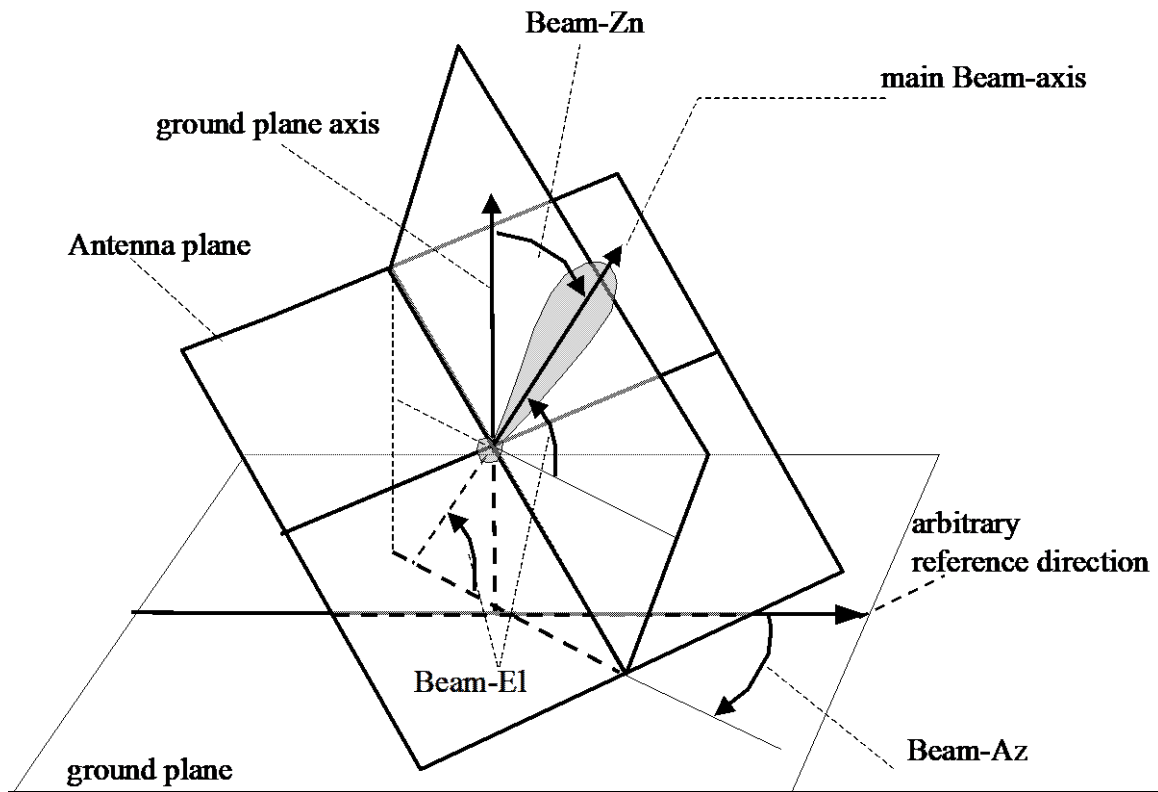

Figure 1b: Reference angles and planes for a passive (e.g. reflector) antenna

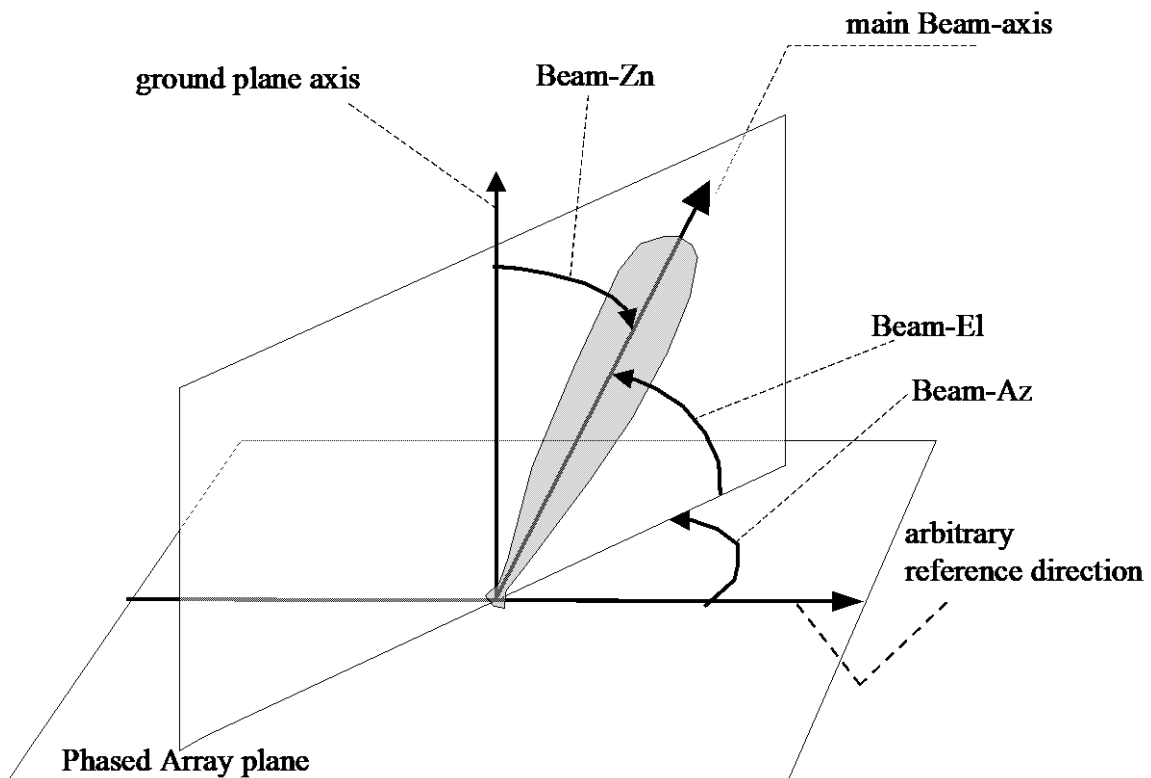
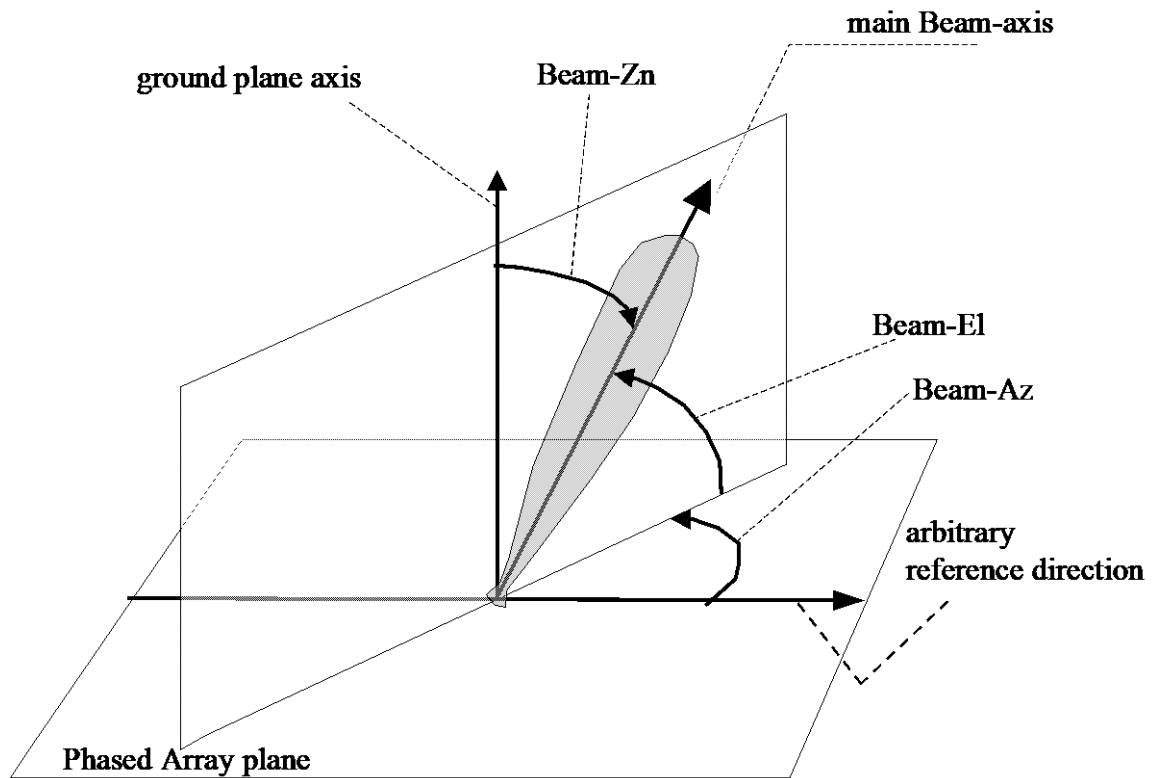

Figure 1c: Reference angles and planes for an active (e.g. phased array) antenna

AMSS network: comprises the 14 GHz AESs, geostationary satellite, LES and NCF

ancillary equipment: equipment used in connection with an AES is considered as ancillary if the three following conditions are met:

- a) the equipment is intended for use in conjunction with the AES to provide additional operational and/or control features (e.g. to extend control to another position or location); and
- b) the equipment cannot be used on a stand alone basis, to provide user functions independently of the AES; and
- c) the absence of the equipment does not inhibit the operation of the AES.

antenna plane: for a passive antenna, plane orthogonal to the main beam axis direction. For a phased array antenna, the antenna plane is the phase array plane

NOTE: See figure 1b.

~~**applicant:** manufacturer or his authorized representative within the European Community or the person responsible for placing the apparatus on the market~~

beam Az angle: angle between an arbitrary reference direction (declared specified by the manufacturer) within the ground plane and the orthogonal projection of the main beam axis within that plane

NOTE 1: See figures 1b and 1c.

NOTE 2: In case of a rectangular phased array antenna such reference direction may be taken, for example, as the direction parallel to the longer of the two sides.

NOTE 3: When the ground plane axis is vertical and the reference direction oriented towards the north or the south, then the beam Az angle is the main beam azimuth angle.

beam El angle: angle between the ground plane and the main beam axis

NOTE: See figures 1b and 1c.

beam Zn angle: angle between the ground plane axis and the antenna main beam axis

NOTE: See figures 1b and 1c.

carrier-off state: state in which AES is when either it is authorized by the Network Control Facility (NCF) to transmit but when it does not transmit any signal, or when it is not authorized by the NCF to transmit

carrier-on state: state in which AES is when it is authorized by the NCF to transmit and when it transmits a signal

Control Channel (CC): channel or channels by which AES receive control information from the NCF of their network

NOTE: The CCs are not necessarily on separate RF channels from the RF channels carrying the user data streams.

~~**EIRP_{max}:** maximum EIRP capability of the AES as declared by operating to the applicant GSO Satellite Network~~

environmental profile: range of environmental conditions

Externally Mounted Equipment (EME): those of the modules of the Installable Equipment (IE) which are intended to be mounted externally to the aircraft as stated by the manufacturer

FSS network: comprises the 13 GHz AESs, geostationary satellite, LES and NCF

ground plane: for a passive antenna, the plane over which the antenna is mounted

NOTE: This plane can be specified by the manufacturer. For a phased array antenna, the ground plane is the phase array plane (see figure 1b).

ground plane axis: direction orthogonal to the ground plane

NOTE: See figures 1b and 1c.

GSO Satellite Network: the GSO satellite network the AES is designed to operate with

Installable Equipment (IE): equipment which is intended to be fitted to an aircraft

NOTE: An IE may consist of one or several interconnected modules.

integral antenna: antenna integrated into the AES which may not be removed during the tests ~~according to the applicant's statement~~

Internally Mounted Equipment (IME): those of the modules of the IE which are not ~~declared~~ specified by the manufacturer as EME are defined as IME

Land Earth Station (LES): earth station in the FSS or, in some cases, in the MSS, located at a specified fixed point or within a specified area on land to provide a feeder-link for the MSS or the FSS

main beam axis: direction where the antenna gain is maximum

NOTE: See figures 1b and 1c.

~~**manufacturer**: authorized representative within the Community or the person responsible for placing the apparatus on the market~~

manufacturer: means any natural or legal person who manufactures radio equipment or has radio equipment designed or manufactured, and markets that equipment under his name or trademark

nominal antenna diameter: antenna diameter ~~declared by the manufacturer that~~ is a parameter in performance characteristics and that allows reference to a certain performance specified for the GSO Satellite Network

NOTE: An antenna with circular aperture of diameter equal to the nominal diameter does typically have the performance specified.

Network operators might request antennas of a certain diameter. Then an antenna that is compliant with the requirement for nominal antenna diameter equal to the requested antenna diameter can be used. Manufacturers can mark their equipment with antenna diameters used in the requirements during compliance test.

nominated Bandwidth (Bn): bandwidth of the AES radio frequency transmission ~~nominated~~ declared by the ~~applicant~~ manufacturer

~~NOTE 1: The nominated bandwidth is centred on the transmit frequency and does not exceed 5 times the occupied Bandwidth (Bo). The nominated bandwidth is within the 14,00 GHz to 14,50 GHz transmit frequency band.~~

~~NOTE 2: The nominated bandwidth is wide enough to encompass all spectral elements of the transmission which have a level greater than the specified spurious radiation limits. The nominated bandwidth is wide enough to take account of the transmit carrier frequency stability. This definition is chosen to allow flexibility regarding adjacent channel interference levels which will be taken into account by operational procedures depending on the exact transponder carrier assignment situation.~~

NOTE: See clause 5.2.

occupied Bandwidth (Bo): for a digital modulation scheme-the width of the signal spectrum 10 dB below the maximum in-band density

phased array plane: for a phased array antenna, the plane containing the radiating elements, if it exists, otherwise the closest plane to the radiating elements

NOTE: This plane could be specified by the manufacturer (see figure 1c).

removable antenna: antenna which may be removed from the AES during the tests ~~according to the applicant's statement~~

Response Channel (RC): channel by which AES transmit monitoring information to the NCF

rms value: root mean square value of N measured values x_i is the square root of the sum of the square of the values x_i divided by N:

$$rms\ value = \sqrt{\frac{1}{N} \sum_{i=1}^N x_i^2}$$

spurious radiation: any radiation outside the nominated bandwidth

transmission disabled state: state in which AES is when it is not authorized to transmit by the NCF

transmission enabled state: state in which AES is when it is authorized to transmit by the NCF

3.2 Symbols

For the purposes of the present document, the following symbols apply:

dBc	ratio expressed in decibel relative to the absolute carrier EIRP
dB _i	ratio of an antenna gain to the gain of an isotropic antenna, expressed in decibel
dBsd	Ratio expressed in decibels relative to the spectral density
dBW	ratio of a power to 1 watt, expressed in decibel
dBpW	ratio of a power to 1 pico watt, expressed in decibel
dB μ V/m	square of the ratio of an electric field to 1 μ V/m, expressed in decibel 20 log (electric field / 1 μ V/m)
θ_{\min}	minimum off-axis angle as declared by the manufacturer as defined in clause 4.2.2.2

3.3 Abbreviations

For the purposes of the present document, the following abbreviations apply:

AES	Aircraft Earth Station
AMSS	Aeronautical Mobile Satellite Service
BER	Bit Error Rate
B _n	nominated Bandwidth
B _o	occupied Bandwidth
BW	Bandwidth
CC	Control Channel
CCF	Control Channel reception Failure
CCR	Control Channel correctly Received
CEPT	European Conference of Postal and Telecommunications administrations
CISPR	International SPecial Committee on Radio Interference
CMF	Control and Monitoring Function
EC	European Community
ECC	Electronic Communications Committee (of CEPT)
ED 14D	EUROCAE Document 14D
EFTA	European Free Trade Association
EIRP	Equivalent Isotropically Radiated Power
EIRPsd	EIRP spectral density
EMC	ElectroMagnetic Compatibility
EME	Externally Mounted Equipment
EN	European Norm
EUROCAE	EUROpean Organization for Civil Aeronautical Electronics
EUT	Equipment Under Test
FEC	Forward Error Correction
FS	Fixed Service
FSS	Fixed-Satellite Service
GEUT	Gain of EUT
GSO	Geostationary Satellite Orbit
HPA	High Power Amplifier

<u>HS</u>	<u>Harmonised Standard</u>
<u>IDU</u>	<u>InDoor Unit</u>
IE	Installable Equipment
IEEE	Institute of Electrical and Electronic Engineers
IME	Internally Mounted Equipment
IPR	Intellectual Property Rights
ISO	International Organization for Standardization
ITU-R	International Telecommunication Union - Radiocommunication Seetor sector
LES	Land Earth Station
LNA	Low Noise Amplifier
LNA/D	Low Noise Amplifier/Diplexer
LNB	Low Noise Block
<u>LO</u>	<u>Local Oscillator</u>
LRU	Line Replaceable Unit
LV	Low Voltage
MSS	Mobile Satellite Service
NCF	Network Control Facility
NGSO	None GSO
PFD	Power Flux Density
R&TTE	Radio and Telecommunications Terminal Equipment
RA	Radio Astronomy
RAS	Radio Astronomy Service
RC	Response Channel
RE	Radio Equipment
RED	Radio Equipment Directive
RF	Radio Frequency
rms	root mean square
RTCA	Radio Technical Committee-Aeronautical
SES	Satellite Earth Stations and Systems
SMF	System Monitoring Fail
SMP	System Monitoring Pass
SST	SuperSonic Transport
STD	Standard
STE	Special Test Equipment
STU	Satellite Terminal Unit
VSAT	Very Small Aperture Terminal

4 Technical requirement specifications

4.1 General

4.1.0 Introduction

The transmissions from the AES to the Satellite in the 14,00 GHz to 14,50 GHz band fall under ~~at~~the secondary allocation to the Mobile-Satellite Service (MSS), the transmissions should not cause harmful interference to primary services (e.g. the Fixed-Satellite Service (FSS)) and at the same time cannot claim protection from harmful interference from those services. In relation to Radio Astronomy (RA) service in the band 14,47 GHz to 14,50 GHz (whose allocation is on a secondary basis) the transmissions from AES equipment shall not cause unacceptable interference to RA sites operating in this band.

The transmissions from the AES to the Satellite in the 12,75 GHz to 13,25 GHz band fall under the primary allocation to the FSS. Such transmissions should not cause harmful interference to the stations of the Fixed Services, also with a primary allocation.

The technical requirements of the present document apply under the operational conditions of the equipment ~~declared~~specified by the manufacturer. The operational condition ~~declared~~specified by the manufacturer shall include the ranges of the antenna main beam axis directions relative to the antenna ground plane, or any equivalent limit.

4.1.1 Environmental profile

The technical requirements of the present document apply under the environmental ~~profiles~~ profile for operation of the equipment (~~EME and IME~~), which shall be ~~declared by the manufacturer~~ in accordance with its intended use. The equipment (~~EME and IME~~) shall comply with all the technical requirements of the present document at all times when operating within the boundary limits of the ~~declared operational environmental profiles and for the environmental conditions (as specified in clause B.3) corresponding to the type of equipment as specified in clause B.2~~ profile defined by its intended use.

4.2 Conformance requirements

4.2.1 General

~~The applicant shall declare the~~ The aircraft model for which the AES is designed shall be specified.

Under operational conditions an AES may dynamically change the occupied Bandwidth (Bo) and other transmission parameters (e.g. FEC, modulation, symbol rate) of the transmitted signal. For each occupied bandwidth an EIRP_{max} and a nominated Bandwidth (Bn) shall be ~~declared by~~ as specified for the applicant GSO Satellite Network. The following specifications apply to the AES for each occupied bandwidth and other transmission parameters.

The operational parameters specified for the GSO Satellite Network, referenced in specifications in this clause 4 shall be established in consultation with the manufacturer.

4.2.2 ~~Spurious~~ Off-axis spurious radiation

4.2.2.1 Justification

To limit the level of interference to terrestrial and satellite radio services.

4.2.2.2 Specification

The following specifications apply to the AES transmitting at EIRP values up to and including EIRP_{max}.

- 1) The AES shall not exceed the limits for radiated interference field strength over the frequency range from 30 MHz to 1 000 MHz specified in table 2.

Table 2: Limits of radiated field strength at a test distance of 10 m in a 120 kHz bandwidth

Frequency range	Quasi-peak limits
30 MHz to 230 MHz	30 dB μ V/m
230 MHz to 1 000 MHz	37 dB μ V/m

The lower limits shall apply at the transition frequency.

- 2) When the AES is in the "Transmission disabled" state, the off-axis spurious Equivalent Isotropically Radiated Power (EIRP) from the AES, in the measurement bandwidth, shall not exceed the limits in table 3, for all off-axis angles greater than a minimum off-axis angle (θ_{min}) ~~declared by~~ specified for the manufacturer GSO Satellite Network.

Table 3: Limits of off-axis spurious EIRP - "Transmission disabled" state

Frequency band	EIRP limit	measurement <u>Measurement</u> bandwidth
1,0 GHz to 10,7 GHz	48 dBpW	100 kHz
10,7 GHz to 21,2 GHz	54 dBpW	100 kHz
21,2 GHz to 40,0 GHz	60 dBpW	100 kHz

The lower limits shall apply at the transition frequency.

- 3) When the 14 GHz AES is in the "Transmission enabled" state, i.e. in the carrier-on and carrier-off states, the off-axis spurious EIRP density from the AES, outside the nominated bandwidth, shall not exceed the limits in table 4, for all off-axis angles greater than a minimum off-axis angle (θ_{\min}) ~~declared by~~ specified for the manufacturer GSO Satellite Network.

Table 4: Limits of off-axis spurious EIRP "Transmission Enabled" state

Frequency band	EIRP limit	Measurement bandwidth
1,0 GHz to 3,4 GHz	49 dBpW	100 kHz
3,4 GHz to 10,7 GHz	55 dBpW	100 kHz
10,7 GHz to 13,75 GHz	61 dBpW	100 kHz
13,75 GHz to 14,00 GHz	95 dBpW (see note)	10 MHz
14,50 GHz to 14,75 GHz	95 dBpW (see note)	10 MHz
14,75 GHz to 21,2 GHz	61 dBpW	100 kHz
21,2 GHz to 40,0 GHz	67 dBpW	100 kHz

NOTE: This limit may be exceeded in a frequency band which shall not exceed 50 MHz, centred on the carrier frequency, provided that the on-axis EIRP density at the considered frequency is 50 dB below the maximum on-axis EIRP density of the signal (within the nominated bandwidth) expressed in dBW/100 kHz.
Furthermore, this limit may be exceeded by a factor of $12 \log(h/2 \text{ km})$ (dB), where the h is the height in km of the aircraft above mean sea level and $h > 2 \text{ km}$, for equipment put on the market before 1 January 2004.

The lower limits shall apply at the transition frequency.

- 4) When the 13 GHz AES is in the "Transmission enabled" state, i.e. in the carrier-on and carrier-off states, the off-axis spurious EIRP density from the AES, outside the nominated bandwidth, shall not exceed the limits in table 5, for all off-axis angles greater than a minimum off-axis angle (θ_{\min}) specified for the GSO Satellite Network.

Table 5: Limits of off-axis spurious EIRP "Transmission Enabled" state

Frequency band	EIRP limit	Measurement bandwidth
1,0 GHz to 3,4 GHz	49 dBpW	100 kHz
3,4 GHz to 10,7 GHz	55 dBpW	100 kHz
10,7 GHz to 12,7 GHz	61 dBpW	100 kHz
12,7 GHz to 12,75 GHz	85 dBpW (see note)	100 kHz
13,25 GHz to 13,4 GHz	61 dBpW (see note)	100 kHz
13,4 GHz to 13,75 GHz	61 dBpW	100 kHz
13,75 GHz to 14,00 GHz	85 dBpW	100 kHz
14,00 GHz to 14,50 GHz	85 dBpW	100 kHz
14,50 GHz to 14,75 GHz	85 dBpW	100 kHz
14,75 GHz to 21,2 GHz	61 dBpW	100 kHz
21,2 GHz to 40,0 GHz	67 dBpW	100 kHz

NOTE: This limit may be exceeded in a frequency band which shall not exceed 50 MHz, centred on the carrier frequency, provided that the on-axis EIRP density at the considered frequency is 50 dB below the maximum on-axis EIRP density of the signal (within the nominated bandwidth) expressed in dBW/100 kHz.

The lower limits shall apply at the transition frequency.

In the frequency band 28,0 GHz to 29,0 GHz, for any 20 MHz band within which one or more spurious signals exceeding the above limit of 67 dBpW are present, then the power of each of those spurious signals exceeding the limit shall be added in watts, and the sum shall not exceed 78 dBpW.

For AES designed to simultaneously transmit multiple carriers, the limits apply to the sum of the EIRPs of all the simultaneously transmitted carriers.

For tables 3 and 4 the elevation angle of the AES main beam axis with respect to its local horizontal plane shall not be lower than the following minimum elevation angle (ϵ_{\min}) of the AES main beam axis:

$$\epsilon_{\min} = \max(\epsilon_{0 \text{ km}}, \theta_{\min}) - [\max(\epsilon_{0 \text{ km}}, \theta_{\min}) - \epsilon_{2 \text{ km}}] \cdot (h/2 \text{ km}) \quad \text{for } h \leq 2 \text{ km}$$

$$\varepsilon_{\min} = \theta_{\min} - \arccos(R_e / (R_e + h)) \quad \text{for } h > 2 \text{ km}$$

where:

R_e mean Earth Radius in km (6 378,14 km);

h is the AES altitude, above the mean sea level, in km. The value of h is set to 0 km when the AES is on the ground;

$\varepsilon_{0 \text{ km}}$ is the minimum elevation angle in degrees permitted on the ground: 7° everywhere except in locations where transmissions at lower elevation angles are permitted by the local administrations;

$$\varepsilon_{2 \text{ km}} = \theta_{\min} - \arccos(R_e / (R_e + 2 \text{ km})) = \theta_{\min} - 1,435^\circ \text{ } \underline{435^\circ}.$$

The elevation angles are positive above the local horizontal plane and negative below it.

4.2.2.3 Conformance tests

Conformance tests shall be carried out in accordance with clause 6.1.

4.2.3 On-axis spurious radiation

4.2.3.1 Justification

To limit the level of interference to nearby satellite radio services.

4.2.3.2 Specification

4.2.3.2.1 "Carrier-on" state

The following specification applies to the AES transmitting at EIRP values up to $EIRP_{\max}$.

- 1) In the 14,00 GHz to 14,50 GHz band for 14 GHz AES, or the 12,75 GHz to 13,25 GHz band for 13 GHz AES the EIRP spectral density of the spurious radiation and outside a bandwidth of 5 times the occupied bandwidth centred on the carrier centre frequency shall not exceed:

$$4 - K \quad \text{dBW in any 100 kHz bandwidth.}$$

- 2) In a bandwidth of 5 times the occupied bandwidth centred on the carrier centre frequency, the EIRP spectral density of the spurious radiation, outside the nominated bandwidth, shall not exceed:

$$18 - K \quad \text{dBW in any 100 kHz bandwidth.}$$

K is the factor that accounts for a reduction on the on-axis spurious radiation level in case of multiple AESs operating on the same frequency.

For AESs which are not expected to transmit simultaneously in a same carrier frequency band, the value of K is 0.

For AESs which are expected to transmit simultaneously in a same carrier frequency band with identical or different EIRPs, the value of K for each EIRP of the AES is given by the following formula:

$$K = -10 \log (EIRP / EIRP_{\text{Aggregate}})$$

where:

- EIRP is the on-axis EIRP of the AES within the nominated bandwidth; and
- $EIRP_{\text{Aggregate}}$ is the maximum on-axis aggregate EIRP within the nominated bandwidth of the AMSS system or the FSS (as appropriate) towards the satellite;
- $EIRP_{\text{Aggregate}}$ shall not be exceeded for more than 0,01 % of the time.

The value of $EIRP_{Aggregate}$ and the operational conditions of the AMSS network ~~shall be declared by the applicant for 14 GHz AES or the FSS network for 13 GHz AES~~ shall be as specified for the GSO Satellite Network.

Third order intermodulation limit is -26 dBc within the band 14,00 GHz to 14,50 GHz for 14 GHz AES or the 12,75 GHz - 13,25 GHz band for 13 GHz AES.

NOTE 1: The on-axis spurious radiations, outside the 14,00 GHz to 14,50 GHz band for 14 GHz AES or the 12,75 GHz - 13,25 GHz band for 13 GHz AES, are indirectly limited by clause 4.2.2.2. Consequently no specification is needed.

NOTE 2: ~~Intermodulation limits inside the band 14,00 GHz to 14,50 GHz are to be determined by system design and are subject to satellite operator specifications.~~

For AES designed to transmit simultaneously several different carriers (multicarrier operation), the above limits only apply to each individual carrier when transmitted alone.

4.2.3.2.2 "Carrier-off" state and "transmission disabled" state

In the 14,00 GHz to 14,50 GHz band for 14 GHz AES or the 12,75 GHz - 13,25 GHz band for 13 GHz AES the EIRP spectral density of the spurious radiation (i.e. outside the nominated bandwidth) shall not exceed -21 dBW in any 100 kHz bandwidth.

4.2.3.3 Conformance tests

Conformance tests shall be carried out in accordance with clause 6.2.

4.2.4 Off-axis EIRP emissions density in the nominated bandwidth for 14 GHz AES and the power flux-density resulting from the 13 GHz AES towards any location in the geostationary-satellite orbit

4.2.4.1 Justification

Protection of other GSO satellite systems which use the same 13 GHz and 14 GHz frequency ~~bands~~.

4.2.4.2 Specification

4.2.4.2.1 14 GHz AES

The following specifications apply to the 14 GHz AES transmitting at EIRP values up to $EIRP_{max}$.

The maximum EIRP in any 40 kHz band in any direction ϕ degrees from the AES antenna main beam axis shall not exceed the following limits within 3° of the geostationary orbit:

$$33 - 25 \log(\phi + \delta\phi) - H \text{ dB(W)}, \text{ where } 2,5^\circ \leq \phi + \delta\phi \leq 7,0^\circ$$

$$+12 - H \text{ dB(W)}, \text{ where } 7,0^\circ < \phi + \delta\phi \leq 9,2^\circ$$

$$36 - 25 \log(\phi + \delta\phi) - H \text{ dB(W)}, \text{ where } 9,2^\circ < \phi + \delta\phi \leq 48^\circ$$

$$-6 - H \text{ dB(W)}, \text{ where } 48^\circ < \phi + \delta\phi \leq 180^\circ$$

where ϕ is the angle, in degrees, between the main beam axis and the direction considered.

The value of $\delta\phi$ (relative to the target satellite) is equal to the rms antenna pointing accuracy.

For AESs designed to transmit always at $EIRP_{max}$, H (in dB) is the maximum number of AESs which may transmit at $EIRP_{max}$ as ~~declared by~~ specified for the manufacturer GSO Satellite Network.

For AESs designed to operate in an AMSS network where the EIRP of each AES is determined by the NCF and where the NCF is in charge of the compliance of the aggregate EIRP density with the above mask, H is the margin as ~~declared~~ specified for the manufacturer GSO Satellite Network for compliance with the mask, when the AES is transmitting at $EIRP_{max}$. For NCF which use the antenna pattern or the off-axis EIRPs the manufacturer shall ~~declare~~ specify the applicable pattern, the value of H shall be set to ~~0 dB~~ 0 dB and the AES EIRP density shall not exceed the EIRP density corresponding to the ~~declared~~ specified pattern.

This margin H or this pattern may be a function of the position of the AES relative to the GSO arc.

The antenna pointing accuracy is the accuracy relative to the nominal GSO satellite direction.

For any off-axis direction in the region outside 3° of the geostationary orbital arc, the above limits may be exceeded by no more than 9 dB (Recommendation ITU-R S.524-7 [i.3]). ~~For AES equipment put on the market before 1 January 2004, this latter limit may be further exceeded by no more than 16 dB for directions above the AES horizontal plane only and outside the region within the 3° of the geostationary orbital arc, until such time that an Administration requests protection of operational NGSO systems.9 [i.3]).~~

These limits apply within the set of operational main-beam directions of the AES, defined relative to the AES antenna ground plane, and ~~declared~~ specified for the manufacturer GSO Satellite Network.

~~The applicant shall declare the~~ The maximum on-axis EIRP corresponding to each range of main beam directions and the corresponding envelope of the EIRP density as a function of the off-axis angle, as specified for the GSO Satellite Network. This envelope could also be the EIRP density mask given above. For each range of the main beam directions the above mask in clause-4.2.4.2 shall not be exceeded. The AES shall be able to reduce its on-axis EIRP as required by the NCF in a CC when several AESs are transmitting simultaneously at the same carrier frequency.

4.2.4.2.2 13 GHz AES

The following specifications apply to the 13 GHz AES transmitting at EIRP values up to $EIRP_{max}$:

Under assumed free-space propagation conditions, the power flux-density (Earth-to-space) resulting from the AES shall not exceed $-133 \text{ dB(W/(m}^2 \cdot \text{MHz))}$ towards any location in the geostationary-satellite orbit located more than 9° from the target orbital position.

4.2.4.3 Conformance tests

Conformance tests shall be carried out in accordance with ~~clause~~ clauses 6.3.1 and 6.3.2 for 14 GHz AES and 13 GHz AES, respectively.

4.2.5 Control and Monitoring Functions (CMF/CMFs)

4.2.5.0 General

For the purpose of the CMF definition, the following states of the AES are defined, without presuming the effective implementation of the AES state machine:

- "Non-valid";
- "Initial phase";
- "Transmission disabled"; and
- "Transmission enabled".

Where:

- In the "Non-valid" state and in the "Transmission disable" state (e.g. under any fault condition), the AES is not allowed to transmit.
- In the "Initial phase" state the AES is only allowed to transmit initial bursts.
- In the "Transmission-enabled" state the AES is allowed to transmit.

NOTE: When the AES is in the "Transmission-enabled" the carrier may have two states: the "Carrier-on" state when the AES transmits a signal and the "Carrier-off" state when the AES does not transmit any signal.

When the AES is not allowed to transmit the EIRP limits for the "Transmission disable" state shall apply.

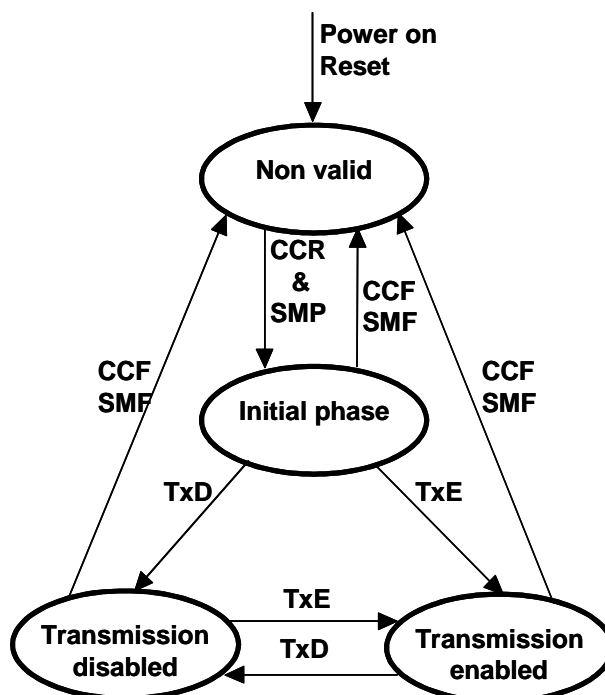

SMP: System Monitoring Pass.
 SMF: System Monitoring Fail.
 TxE: Transmission Enable command.
 TxD: Transmission Disable command.
 CCR: Control Channel correctly Received.
 CCF: Control Channel Reception Failure.

NOTE: From "Transmission disabled" state a TxE command may also result in a transition towards the "Initial phase" state.

Figure 2: Example state transition diagram of the control and monitoring function of the AES

The following minimum set of CMF shall be implemented in AES in order to minimize the probability that they may originate unwanted transmissions that may give rise to harmful interference to other systems.

4.2.5.1 Processor monitoring

4.2.5.1.1 Justification

To ensure that the AES can suppress transmissions in the event of a processor subsystem failure.

4.2.5.1.2 Specification

The AES shall incorporate a processor monitoring function for each of its processors involved in the manipulation of its required traffic and in the control and monitoring functions.

The processor monitoring function shall detect any failure of the processor hardware and software.

After any fault condition occurs, the AES shall enter the carrier-off state within 1 s, if it was in the Transmission enabled state, and within 30 s it shall enter the Transmission disable state until the processor monitoring function has determined that all fault conditions have been cleared.

4.2.5.1.3 Conformance tests

Conformance tests shall be carried out in accordance with clause 6.5.2.

4.2.5.2 Transmit subsystem monitoring

4.2.5.2.1 Justification

To ensure the correct operation of the transmit frequency generation subsystem, and to inhibit transmissions should the subsystem fail.

4.2.5.2.2 Specification

The AES shall monitor the operation of its transmit frequency generation subsystem.

No later than 5 s after any fault condition of the transmit frequency generation subsystem occurs, the AES shall enter the Transmission-disabled state until the transmit subsystem monitoring function has determined that all fault conditions have been cleared.

4.2.5.2.3 Conformance tests

Conformance tests shall be carried out in accordance with clause 6.5.3.

4.2.5.3 Power-on/Reset

4.2.5.3.1 Justification

To demonstrate that the AES achieves a controlled non-transmitting state following the powering of the unit or the occurrence of a reset made by a local operator when this function is implemented.

4.2.5.3.2 Specification

During and following "power on" or a manual reset when this function is implemented, the AES shall remain in the Transmission-disabled state.

4.2.5.3.3 Conformance tests

Conformance tests shall be carried out in accordance with clause 6.5.4.

4.2.5.4 Control Channel (CC) reception

4.2.5.4.1 Justification

To ensure that the AES cannot transmit unless it correctly receives the CC messages from the NCF.

4.2.5.4.2 Specification

- a) Without correct reception of the CC messages from the NCF, the AES shall remain in the Transmission-disabled state.
- b) When in the Transmission enabled state, the AES shall enter the Transmission disabled state immediately after a period not exceeding 30 s without correct reception of the CC messages from the NCF.

4.2.5.4.3 Conformance tests

Conformance tests shall be carried out in accordance with clause 6.5.5.

4.2.5.5 Network control commands

4.2.5.5.1 Justification

These requirements ensure that the AES is capable of:

- a) retaining a unique identification in the network and transmitting it upon reception of an appropriate request;
- b) receiving commands from the NCF through its CC and executing those commands.

4.2.5.5.2 Specification

The AES shall hold, in non-volatile memory, its unique identification code in the network.

The AES shall be capable of receiving through its CC dedicated commands (addressed to the AES) from the NCF, and which contain:

- transmission enable commands, including the transmission parameters (at least the EIRP, the data rate and carrier centre frequency);

NOTE: The transmission parameter may be transmitted by any means (e.g. a value or a reference to a set of values).

- transmission disable commands;
- identification request.

The transmission parameters of the AES shall be only those authorized by the NCF through the CC.

When, any transmission parameter change in a CC message is received by the AES, it shall implement that change within 1 s.

Once a transmission enable command is received the AES is authorized to transmit.

After power-on or reset the AES shall remain in the Transmission disabled state until it receives a transmission enable command. For systems where no transmission enable command is expected after power-on or reset the AES may only transmit initial bursts (see clause 4.2.5.6).

Once a transmission disable command is received, within 1 s the AES shall enter and shall remain in the Transmission disabled state until the transmission disable command is superseded by a subsequent transmission enable command.

The AES shall be capable of transmitting its identification code upon reception of an identification request.

4.2.5.5.3 Conformance tests

Conformance tests shall be carried out in accordance with clause 6.5.6.

4.2.5.6 Initial burst transmission

4.2.5.6.1 General

Restrictions on the initial burst transmissions are necessary to limit disturbance to other services.

4.2.5.6.2 Specification

For AMSS Systems where no transmission enable command is foreseen without request from the AES, in the "Initial phase" state the AES may transmit initial bursts.

- a) The duty cycle of the burst retransmission shall not exceed 0,2 %.
- b) Each burst shall not carry more than 256 data bytes excluding the burst preambles and the FEC coding bits.
- c) The initial burst shall be transmitted at an EIRP up to $EIRP_{max}$.

The requirements for the Transmission enable state shall apply during the transmission of each initial burst.

4.2.5.6.3 Conformance tests

Conformance tests shall be carried out in accordance with clause 6.5.7.

4.2.6 Power Flux Density at the surface of the earth

4.2.6.40 General

~~The limitation~~ Different specifications apply to the limitations of the Power Flux Density (PFD) at the surface of the Earth ~~shall be controlled either by the for 13 GHz AES itself, or by the NCF and 14 GHz AES.~~

4.2.6.1 14 GHz AES

4.2.6.1.1 Power flux density limits in the 14,00 GHz to 14,50 GHz frequency band

4.2.6.21.1.1 Justification

In Europe, some countries operate Fixed Service (FS) links in the band 14,25 GHz to 14,50 GHz (shared band with FSS) on a primary basis (i.e. France, Italy and United Kingdom; see ITU Radio Regulations [i.5], footnotes 5.508a and 5.509a-[i.5]) and Radio Astronomy Service (RAS) in the band 14,47 GHz to 14,50 GHz (shared with the FSS) on a secondary basis (i.e. France, Italy, United Kingdom and Spain; see ITU Radio Regulations [i.5], footnotes 5.504b and 5.504c-[i.5]).

In other countries outside Europe FS links may operate in other parts of the 14,00 GHz to 14,50 GHz band on a primary basis as per ITU Radio Regulations [i.5], footnotes 5.505, 5.508, 5.508a and 5.509a-[i.5] and Radio Astronomy Service (RAS) in the band 14,47 GHz to 14,50 GHz on a secondary basis as per ITU Radio Regulations [i.5], footnotes 5.504b and 5.504c-[i.5].

Based on the above, there is a requirement for protection of FS systems in the band 14,00 GHz to 14,50 GHz and RAS sites in the band 14,47 GHz to 14,50 GHz from in-band and out-band emissions of 14 GHz AES operating in the band 14,00 GHz to 14,50 GHz on a secondary basis. The specification of protection of FS systems and RAS is based on the Power Flux Density (PFD) limits per 14 GHz AES.

The PFD requirement for protection of FS systems is applicable when the 14 GHz AES is in line of sight with a country employing such FS systems and could be relaxed if the operator of the 14 GHz AES network has an agreement with the Administration of that country.

The PFD requirement for protection of specific RAS sites is applicable when the 14 GHz AES is in line of sight of the specific RAS sites.

~~Even though the NCF is outside the scope of the present document, within the present clause on PFD limitation, the applicant is required to declare the minimum requirement for a NCF operating the AES and for the purpose of the PFD limitation.~~

The limitation of the Power Flux Density (PFD) at the surface of the Earth shall be controlled either by the 14 GHz AES itself, or by the NCF.

4.2.6.21.1.2 Specification 1: Mode of PFD limitation

Two modes of limitation may be implemented for this PFD limitation:

- a) the "partially remote controlled mode" where the NCF determines that the PFD shall be limited and regularly transmits to the 14 GHz AES the necessary information for the determination and the update of the 14 GHz AES transmission parameters, by the 14 GHz AES itself;
- b) the "full remote controlled mode" where the NCF determines that the PFD shall be limited and regularly transmits all the necessary transmission parameters to the 14 GHz AES.

At least one of these two modes shall be implemented within the 14 GHz AES.

The applicant following shall declare as specified for the GSO Satellite Network:

- the modes of limitation which are implemented within the 14 GHz AES;
- the 14 GHz AES interfaces involved in the PFD limitation:
 - the list of relevant parameters which are collected by the 14 GHz AES for the transmission parameter determination by the 14 GHz AES and the NCF (e.g. the aircraft altitude, latitude, longitude, attitude);
 - the list of these relevant parameters which are used by the 14 GHz AES for the transmission parameter determination;
 - the list of these relevant parameters which are transmitted by the 14 GHz AES to the NCF for the transmission parameter determination;
 - the list of the transmission parameters which are received by the 14 GHz AES from the NCF for the transmission parameter determination;
 - for the collected relevant parameters, the 14 GHz AES interface(s), including the protocols, the timing, the ranges of the values, the speed of the variations and the required accuracies;
 - for the relevant parameters transmitted to the NCF, the 14 GHz AES interface with the NCF, including the protocols and the timing;
 - for the transmission parameter received from the NCF, the 14 GHz AES interface with the NCF, including the protocols and the timing;
 - these ~~declared~~ 14 GHz AES interfaces shall be in accordance with the user documentation.

4.2.6.21.1.3 Specification 2: Location where to limit the PFD

Location 1: When the 14 GHz AES is operating in the frequency band from 14,00 GHz to 14,50 GHz and within the line-of-sight of the territory of an Administration where the Fixed Service networks are operating in this frequency band, the PFD produced at the surface of the Earth by emissions from the 14 GHz AES shall be limited as specified in specification 3a. The territory of Administrations where Fixed Service networks are operating in this frequency band are defined by the ITU Radio Regulations [i.5], footnotes 5.505, 5.508, 5.508a and 5.509a-~~[i.5]~~.

Location 2: When the 14 GHz AES is operating in the frequency band from 14,00 GHz to 14,50 GHz and within the line-of-sight of the RAS site operating in the frequency band 14,47 GHz and 14,50 GHz, the PFD produced at the surface of the Earth by emissions from the 14 GHz AES shall be limited as specified in specification 3b. The Administrations where RAS sites are operating in this frequency band are defined by the ITU Radio Regulations [i.5], footnotes 5.504b and 5.504c-~~[i.5]~~.

For an 14 GHz AES which determines partially where to limit the PFD, based on its location, the 14 GHz AES shall be able to determine where to limit the PFD with the accuracy ~~declared by~~ as specified for the applicant GSO Satellite Network.

For AMSS networks where the NCF determines completely or partially where to limit the PFD, based on the 14 GHz AES location, the collection of the relevant parameters by the 14 GHz AES and the exchange of information between the 14 GHz AES and the NCF shall be sufficient for the NCF to determine where to limit the PFD with the accuracy ~~declared by~~ as specified for the applicant GSO Satellite Network, and to inform in time the 14 GHz AES to limit the PFD.

The determination of the locations where a PFD limitation is necessary, for the protection of the FS or RAS or both, shall take into account the inaccuracy of the 14 GHz AES location and of the country borders or RAS specific sites in the data base used either by the AES or the NCF, as ~~declared by applicants~~ specified for the GSO Satellite Network.

4.2.6.21.1.4 Specification 3: PFD limitation

Specification 3a

When the 14 GHz AES PFD at the surface of the Earth shall be limited, for the protection of FS in the band 14,25 GHz to 14,50 GHz, then the PFD at the surface of the Earth shall not exceed the PFD limits of annex B of Recommendation ITU-R M.1643 [5].

This specification 3a applies in the band 14,25 GHz to 14,50 GHz when the AES is operating in the 14,00 GHz to 14,50 GHz.

Specification 3b

When the 14 GHz AES PFD at the surface of the Earth shall be limited, for the protection of RAS sites in the band 14,47 GHz to 14,50 GHz, then the PFD at the surface of the Earth shall not exceed the PFD limits of annex C of Recommendation ITU-R M.1643 [5].

This specification 3b applies in the band 14,47 GHz to 14,50 GHz when the AES is operating in the 14,00 GHz to 14,50 GHz.

Specification 3c

The above specifications 3a and 3b apply for any 14 GHz AES altitude relative to sea level within the operational altitude range of the 14 GHz AES as ~~declared~~specified by the manufacturer. Outside this range of altitude the 14 GHz AES shall not transmit.

The above specifications 3a and 3b apply for the relevant parameters within the ranges ~~declared by~~specified for the ~~applicant~~GSO Satellite Network. In case of a relevant parameter out of the specified range 14 GHz AES shall not transmit.

The relationship between the PFD, the EIRP and the altitude (h) of the 14 GHz AES is given in annex D of Recommendation ITU-R M.1643 [5].

For an 14 GHz AES which determines partially where to limit the PFD, based on its location, the 14 GHz AES shall be able to limit the PFD as specified above taking into account the inaccuracies ~~declared by~~specified for the ~~applicant~~GSO Satellite Network.

For AMSS networks where the NCF determines completely or partially where to limit the PFD, based on the 14 GHz AES location, the collection of relevant parameters by the 14 GHz AES and the exchange of information between the 14 GHz AES and the NCF shall be such that with the information received from the NCF the 14 GHz AES is able to limit the PFD as specified above taking into account the inaccuracies ~~declared by~~specified for the ~~applicant~~GSO Satellite Network.

4.2.6.21.1.5 Specification 4: Fault conditions

Any collection or transmission of the relevant parameters to the NCF which have not been completed correctly within the required delay(s) ~~declared by~~specified for the ~~manufacturer~~GSO Satellite Network, shall be considered as a fault condition. In this case the 14 GHz AES shall enter the "Transmission disabled" state.

Any transmission parameter not received or not correctly received from the NCF within the required delay ~~declared by~~specified for the ~~manufacturer~~GSO Satellite Network shall be considered as a fault condition. In this case the 14 GHz AES shall enter the "Transmission disabled" state.

4.2.6.21.1.6 Conformance tests

Conformance tests shall be carried out in accordance with clause 6.4.1.

4.2.6.2 13 GHz AES

4.2.6.2.0 General

The limitation of the Power Flux Density (PFD) at the surface of the Earth resulting from the AES shall be controlled by the NCF.

4.2.6.2.1 Justification

European countries and countries elsewhere operate Fixed Service (FS) links in the band 12,75 GHz to 13,25 GHz (shared band with FSS) on a primary basis. The CEPT has stipulated the requirements for the protection of FS in the band 12,75 GHz to 13,25 GHz in the ECC Decision (19)04 [6]. According to these requirements each 13 GHz AES has to meet the Power Flux Density (PFD) limits on the surface of the Earth given in the ECC Decision; viz.:

$-123,5$	$\text{dB(W/(m}^2 \cdot \text{MHz))}$	for	$\theta \leq 5^\circ$
$-128,5 + \theta$	$\text{dB(W/(m}^2 \cdot \text{MHz))}$	for	$5^\circ < \theta \leq 40^\circ$
$-88,5$	$\text{dB(W/(m}^2 \cdot \text{MHz))}$	for	$40^\circ < \theta \leq 90^\circ$

where θ is the angle of arrival with respect to the horizontal plane at the Fixed Service station location.

4.2.6.2.2 Specification

The NCF shall continually determine the PFD on the earth and transmit, when required, necessary transmission parameters to the 13 GHz AES through its CC commands in order to maintain the PFD on earth at the limits set by the ECC Decision (19)04 [6]. If the PFD limits on earth are to be exceeded the NCF shall transmit the disable command to the 13 GHz AES through its CC.

The 13 GHz AES processor, including its hardware and software, shall be a part of the processor subsystem referenced within Control and Monitoring Functions (CMFs) in clause 4.2.5.

When, a change in the transmission parameter or the transmit disable command is received at the AES as a CC command, the AES shall implement the command within 1 s.

4.2.6.2.3 Conformance tests

Conformance tests shall be carried out in accordance with clause 6.4.2.

4.2.7 Receive antenna off-axis gain pattern

4.2.7.1 Justification

To protect the wanted signals from interference from terrestrial services and from other satellite services.

4.2.7.2 Specification

The maximum antenna gain of each of the co-polarized components in any direction φ degrees from the antenna main beam axis shall not exceed the following limits:

$$G = 32 - 25 \log \varphi \text{ dBi for } \varphi_{min} \leq \varphi < 48^\circ$$

$$G = -10 \text{ dBi for } 48^\circ \leq \varphi \leq 85^\circ$$

$$G = 0 \text{ -dBi for } 85^\circ \leq \varphi \leq 180^\circ$$

where:

$$\varphi_{min} = 1^\circ \text{ or } 100 \lambda/D \text{ degrees, whichever is the greater, for } D/\lambda \geq 50.$$

$$\varphi_{min} = 2^\circ \text{ or } 114 (D/\lambda)^{-1,09} \text{ degrees, whichever is the greater, for } D/\lambda < 50.$$

D is the nominal diameter of the antenna.

In addition the maximum antenna gain of each of the cross-polarized components in any direction φ degrees from the antenna main beam axis shall not exceed the following limits:

$$G_x(\varphi) = 23 - 20 \log \varphi \text{ dBi for } \varphi_r \leq \varphi \leq 7^\circ$$

where φ_r is equal to 1° or $100 \lambda/D$, whichever is greater.

4.2.7.3 Conformance tests

Conformance tests shall be carried out in accordance with clause 6.6.

4.2.8 Blocking performance

4.2.8.1 Justification

To prevent high power signals outside the receive frequency band from blocking the reception of wanted signals inside the receive frequency band.

4.2.8.2 Specification

Receiver blocking is characterized here through gain compression for a signal inside the receive frequency band that is caused by another signal outside the receive frequency band at high power. The level of the other signal is compared to the level of a signal inside the receive frequency band that would cause the same gain compression.

Receiver blocking rejection at a particular frequency is defined as the level of a second signal at this frequency that causes a certain gain compression to a first signal inside the receive frequency band, minus the level of a second signal at a frequency inside the receive frequency band that causes the same gain compression.

The first signal shall be at the centre frequency of the receive frequency band and have a level in the operational range. The second signal shall cause a gain compression for the first signal of 1 dB.

The rejection shall comply with table 56.

Table 56: Receiver blocking rejection

Frequency range	Minimum rejection
below 1) 6 GHz to 9 GHz	20 dB
2) 9 GHz to 10 GHz	10 dB
3) 14 GHz to 16 GHz	10 dB
Above 16 GHz	20 dB
NOTE: In the frequency ranges 10 to 10,7 GHz and 12,75 to 14 GHz, the rejection needs further studies.	<u>20 dB</u>
4) 16 GHz to 30 GHz	

4.2.8.3 Conformance tests

Conformance tests shall be carried out in accordance with clause 6.7.

4.2.9 ~~Adjacent Signal Selectivity~~ signal selectivity

4.2.9.1 Justification

To enable reception of a wanted signal in presence of other signals on adjacent frequencies which are transmitted with high EIRP density from target satellite orbital position.

NOTE: The power level of signals transmitted from the same orbital position are under control of the satellite operator. Signals transmitted from an adjacent orbital position that is not near-by are suppressed by the antenna gain pattern.

4.2.9.2 Specification

~~Adjacent Signal Selectivity~~ signal selectivity is a measure of a receiver's ability to receive a signal at its assigned channel frequency in the presence of an adjacent signal at a given frequency offset from the centre frequency of the assigned channel.

The adjacent signal shall occupy the same bandwidth as the wanted signal. Frequency offset between adjacent signal and relative wanted signal shall be equal to the bandwidth of the wanted signal. The power level of the adjacent signal compared to the wanted signal shall take the value given in table 6. BW is shall be 7 dB higher than the power level of the wanted signal-occupied bandwidth.

Table 6: Adjacent signal frequency and Power level

Signal	Centre frequency offset from wanted signal	Power level relative to wanted signal
Adjacent Carrier	BW	7 dBsd

The decrease in the ~~required~~ measured signal to noise ratio in the presence of an adjacent signal shall be no more than 0,5 dB.

4.2.9.3 Conformance tests

Conformance tests shall be carried out in accordance with clause 6.8.

4.2.10 Image frequency rejection

4.2.10.1 Justification

With a LO frequency lower than the received frequency, the image frequency lies in a spectrum region allocated to high-power systems including radiolocation. Protection is necessary against the resulting interference.

4.2.10.2 Specification

The LNB shall suppress the image frequencies of the received frequencies by at least 30 dB in case the image frequency falls inside the overall receive frequency band of the EUT and at least 40 dB otherwise.

4.2.10.3 Conformance tests

The test method specified in clause 6.1.8 of ETSI ETS 300 457 [7] shall apply.

NOTE 1: If the LNB is integrated with a feed horn, then the input signal may be injected by a feed horn adaptor. The LNB manufacturer should supply the feed horn adaptor and characterization frequency and gain data. The data supplied should be used to correct the measurements taken.

NOTE 2: If signal injection through free space radiation in an anechoic chamber achieves higher accuracy of measurement results, this method may be used.

5 Testing for compliance with technical requirements

5.1 Environmental conditions for testing

Tests defined in the present document shall be carried out at representative points within the boundary limits of the ~~declared~~ operational environmental profile ~~(see annex B)~~ defined by its intended use.

Where technical performance varies subject to environmental conditions, tests shall be carried out under a sufficient variety of environmental conditions (within the boundary limits of the operational environmental profile defined by its intended use) to give confidence of compliance for the affected technical requirements.

5.2 ~~Essential~~ Nominated Bandwidth

The nominated bandwidth is the bandwidth of the AES radio frequency transmission nominated for the GSO Satellite Network. The nominated bandwidth is centred on the transmit frequency and does not exceed 5 times the occupied Bandwidth (Bo). The nominated bandwidth of an AES is within the transmit frequency bands specified in table 1. The nominated bandwidth is wide enough to encompass all spectral elements of the transmission which have a level greater than the specified spurious radiation limits. The nominated bandwidth is wide enough to take account of the transmit carrier frequency stability. This definition is chosen to allow flexibility regarding adjacent channel interference levels

which will be taken into account by operational procedures depending on the exact transponder carrier assignment situation.

~~test suites~~

~~The essential radio test suites for an AES are given in clause 6.~~

6 Test methods

6.0 General

The AES will consist of equipment located within the interior of an aircraft fuselage (Internally Mounted Equipment or IME) and mounted on the exterior of the aircraft (Externally Mounted Equipment or EME). ~~In addition, the externally mounted equipment will be designed and tested to meet the requirements given in clause 4, as tested per the procedures in this clause.~~

Formal testing will be accomplished under the direction of a test procedure. This test procedure will have been created specifically for testing the exact equipment intended for qualification or certification. The test procedure will describe or provide reference to all expected test conditions and parameters, including cable harness construction details, all equipment set-up, interconnect, placement and configuration details, instructions for operating the device and for determining its proper operation, and any necessary instructions for performing the test measurements.

Measurement Accuracy: ~~The values of measurement uncertainty associated with each measurement parameter apply to all of the test cases described in the present document. The measurement uncertainties shall not exceed the values shown in tables 7 and 8.~~

~~Table 7: Measurement uncertainty~~

Measurement parameter	Uncertainty
Radio frequency	±10 kHz
RF power	±0,75 dB
Conducted spurious	±4 dB
Radiated spurious	±6 dB
Antenna on axis gain	±2 dB

~~Table 8: Measurement uncertainties for antenna gain pattern~~

Gain relative to the antenna on axis gain	Uncertainty
> 3 dB	±0,3 dB
-3 dB to -20 dB	±1,0 dB
-20 dB to -30 dB	±2,0 dB
-30 dB to -40 dB	±3,0 dB

Monitoring Function: To enable the performance tests to be carried out, the use of a NCF Control Channel or a Special Test Equipment (STE) made available by the ~~applicant or system provider, manufacturer~~ may be necessary. Since this STE will be specific for the particular system, it is not possible to provide detailed specifications in the present document. However, the following baseline is provided:

- if the AES shall receive a modulated carrier from the satellite in order to transmit, then special test arrangements are required to simulate the satellite signal, thus enabling the system to transmit, thereby allowing measurement of transmission parameters;
- any characteristic of these special test arrangements which may have direct or indirect effects on the parameters to be measured shall be clearly stated by the ~~applicant~~ manufacturer.

~~The test procedures given in clause 6 may be replaced by other equivalent procedures provided that the results are proven to be as accurate as those obtained according to the specified method. Because each applicant's equipment may~~

~~be different, then different test methods can be suggested and proposed by the applicant to account for the different equipment characteristics. Specific test procedures shall be fully documented in the test procedure and test report.~~

All tests with carrier-on shall be undertaken with the transmitter operating at maximum power and with the maximum transmit burst rate, where applicable, which shall be ~~declared by the applicant~~ as specified for the GSO Satellite Network.

If the Equipment Under Test (EUT) has had hardware and/or software modification(s) performed by the ~~applicant~~ manufacturer for these tests, then full documentation of such modification(s) shall be provided to prove that the modification(s) will simulate the required test condition. Such modification(s) shall be proved to allow the AES to operate without its main characteristics being changed.

All technical characteristics and operational conditions ~~declared by the applicant~~ specified for the NGSO Satellite System, referenced in connection with the test methods in this clause 6, shall be entered in the test report.

6.1 ~~Spurious~~ Off-axis spurious radiation

6.1.1 Test method

6.1.1.0 Introduction

An EUT comprises all of the exterior mounted Line Replaceable Units (LRUs), including the antenna and radome (if any). These LRUs shall be interconnected by the longest cable expected to be seen in service as recommended by the ~~applicant~~ manufacturer, or, if that is unknown, by a 10 m cable. The connecting cable between the internal and the external units shall be the same type as recommended by the ~~applicant~~ manufacturer in the installation manual. The type of cable used shall be entered in the test procedure and the test report.

Because an AES antenna is typically attached directly to the skin of the airplane fuselage, and is usually the primary aperture for externally generated emissions, testing without an antenna will not be an option, herein.

The internal unit(s) shall be terminated with matched impedances at the interface ports if there is no associated equipment connected to such ports and if recommended by the ~~applicant~~ manufacturer in the user documentation.

Antennas

For frequencies up to 80 MHz the measuring antenna shall be calibrated according to the requirements of CISPR 16-1-~~2-1~~ [2].

For frequencies between 80 MHz and 1 000 MHz the measuring antenna shall be calibrated according to the requirements of CISPR 16-1-~~2-1~~ [2].

For frequencies above 1 000 MHz the antenna shall be a horn radiator of known gain/frequency characteristics. ~~When used for reception, the antenna and any associated amplification system shall have an amplitude/frequency response within ± 2 dB of the combined calibration curves across the antenna's measurement frequency range.~~ The antenna is mounted on a support capable of allowing the antenna to be used in either horizontal or vertical polarization and at the specified height.

6.1.1.1 Up to 1 000 MHz (see clause 4.2.2.2, table 2)

6.1.1.1.1 Test site

The test shall be performed either in an open area test site, a semi-anechoic chamber, or an anechoic chamber. Ambient noise levels shall be at least 6 dB below the applicable unwanted emissions limit.

The open area test site shall be flat, free of overhead wires and nearby reflecting structures, sufficiently large to permit aerial placement at the specified measuring distance and provide adequate separation between aerial, test unit and reflecting structures, according to the specification of CISPR 16-1-~~2-1~~ [2].

For both the open area test site and the semi-anechoic chamber a metal ground plane shall be inserted on the natural ground plane and it shall extend at least 1 m beyond the perimeter of the EUT at one end and at least 1 m beyond the measurement antenna at the other end.

The distance between the EUT and measuring antenna should be 10 m. For measurements at a different distance an inverse proportionality factor of 20 dB per decade shall be used to normalize the measured data to the specified distance for determining compliance. Care should be taken in measurement of large test units at 3 m at frequencies near 30 MHz due to near field effects.

6.1.1.1.2 Measuring receivers

The measuring receiver will either be located outside the test area such that no radiations from the measuring receiver in the band of interest are detectable at the measuring antenna, or the test area will be calibrated without the EUT to determine the contribution of the receiving equipment active elements.

Measuring receivers shall conform to the following characteristics:

- the response to a constant amplitude sine wave signal shall remain within ± 1 dB across the frequency range of interest;
- quasi-peak detection shall be used in a -6 dB bandwidth of 120 kHz;
- the receiver shall be operated below the 1 dB compression point.

6.1.1.1.3 Procedure

- a) The EUT shall be all exterior mounted LRUs.
- b) The EUT shall be in the carrier-on state.
- c) The EUT shall be rotated in azimuth through 360° in minimum steps of 45° and, except in an anechoic chamber, the measuring antenna height simultaneously varied from 1 m to 4 m above the ground plane. Alternatively, the measuring antenna may be moved around the EUT at a fixed distance from the EUT.
- d) All identified spurious radiations shall be measured and noted in frequency and level.
- e) The boresight of the antenna shall be pointing at zenith, i.e. upwards.

6.1.1.2 Above 1 000 MHz (see clause 4.2.2.2, tables 3 and 4)

6.1.1.2.0 General

The spectrum analyser resolution bandwidth shall be set to the specified measuring bandwidth or as close as possible. If the resolution bandwidth is different from the specified measuring bandwidth, a bandwidth correction shall be performed for the noise-like wideband spurious emissions.

Tests shall be performed in two stages for both the carrier-on and carrier-off states:

Procedure a) Identification of the significant frequencies of spurious radiation.

Procedure b) Measurement of radiated power levels of identified spurious radiation.

6.1.1.2.1 Identification of the significant frequencies of spurious radiation

6.1.1.2.1.1 Test site

The identification of frequencies emitting from the EUT shall be performed either in an anechoic chamber, an open area test site or a semi-anechoic chamber with the test antenna close to the EUT and at the same height as the volume centre of the EUT. See also figure 3 for the AES positioning.

6.1.1.2.1.2 Procedure

- a) The EUT shall be in the carrier-off state.
- b) The main beam of the antenna shall have an angle of elevation equal to θ_{\min} .

- c) The measuring receivers shall scan the frequency band while the EUT revolves or the test antenna is moved around the EUT.
- d) The EUT shall be rotated in azimuth through 360° in minimum steps of 45° and the frequency of any spurious signals noted for further investigation. Alternatively, the measuring antenna may be moved around the EUT at a fixed distance from the EUT.
- e) The test shall be repeated with the test antenna being in the opposite polarization.
- f) The test shall be repeated in the carrier-on state while transmitting one modulated carrier at maximum power.

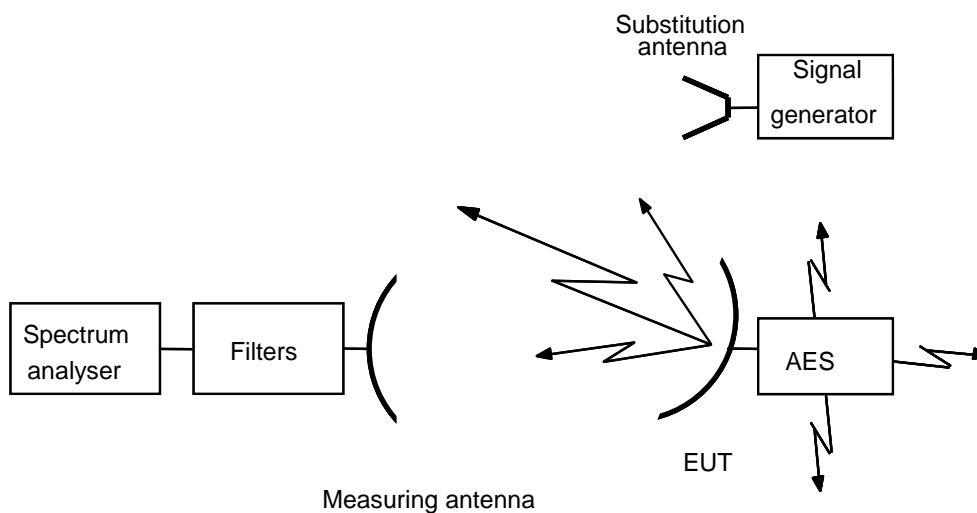

Figure 3: Test arrangement-spurious radiation measurement above 1 000 MHz for an EUT with antenna

6.1.1.2.2 Measurement of radiated power levels of identified spurious radiation

6.1.1.2.2.1 Test site

The measurement of each spurious radiation noted during procedure a) of the test shall be performed on a test site that is free from reflecting objects, i.e. either an open-area test site, a semi-anechoic chamber or an anechoic chamber. See also figure 3 for the AES positioning.

6.1.1.2.2.2 Procedure

- a) The test arrangement shall be as shown in figure 3.
- b) The EUT shall be installed such that if there are more than one LRU under simultaneous test, they are separated by about 1 m to 2 m. The height at which the EUT is tested will be determined by the manufacturer. The interconnection cable shall be maintained by non-conductive means at a height from the ground plane simulating the worst-case expected airplane installation for wiring relative to the fuselage. For the test arrangement shown in figure 3 the main beam of the antenna shall have an angle of elevation equal to θ_{\min} and be oriented away from the geostationary orbit, or be inhibited by placing RF absorbing panels in that direction (this is to minimize interference towards the GSO satellites while the test is performed). For antennas designed for minimum off-axis gain in the direction of the geostationary orbit plane, the plane containing the larger cut of the main lobe shall be set vertical.
- c) The measuring antenna shall be positioned at a distance from the EUT (e.g. 3 m, 5 m, 10 m) relevant to the applied test site. The measuring antenna shall be adjusted in height and the EUT rotated or the measuring antenna move around the EUT, while the EUT is in the appropriate carrier condition. For the maximum response on the associated spectrum analyser at each spurious frequency previously identified, the response level shall be noted. The adjustment in height of the measuring antenna does not apply when an anechoic chamber is being used. The measuring antenna shall not enter the θ_{\min} off-axis cone around the main beam direction.

- d) The investigation shall be repeated with the measuring antenna in the opposite polarization and the response level similarly noted.
- e) The EUT shall be replaced by the substitution antenna to which is connected a signal generator. The main beam axes of the measuring and substitution antennas shall be aligned. The distance between these antennas shall be the distance determined under test c).
- f) The substitution and measuring antennas shall be aligned in the polarization which produced the larger response between the EUT and the test antenna in steps c) and d).
- g) The output of the generator shall be adjusted so that the received level is identical to that of the previously noted largest spurious radiation, for each frequency identified as a spurious signal.
- h) The output level of the signal generator shall be noted. The EIRP of the spurious radiation is the sum, in dB, of the signal generator output plus the substitution antenna isotropic gain minus the interconnection cable loss.
- i) ~~For equipment which take account of the relaxation factor $12 \log (h/2 \text{ km})$ (dB) and which are put on the market before 1 January 2004, the test shall be executed at AES altitudes equal to 0 km, 2 km, 4 km, 8 km and 12 km, or to the closest altitude within the range of operational altitudes as declared by the manufacturer.~~

6.2 On-axis spurious radiation

6.2.1 Test method

6.2.1.1 ~~Test site~~ Void

~~There are no requirements for the test site to be used for this test.~~

6.2.1.2 Method of measurement

6.2.1.2.1 General

The tests shall be undertaken with the transmitter operating at $EIRP_{max}$.

For AES equipment for which measurements at the antenna flange are not possible or not agreed by the ~~applicant~~ manufacturer, the measurements shall be performed with a test antenna.

For AES equipment for which measurements at the antenna flange are possible and agreed by the ~~applicant~~ manufacturer, the measurements shall be performed at the antenna flange. The EUT is the AES with its antenna comprising both the internal and external units.

6.2.1.2.2 Method of measurement at the antenna flange

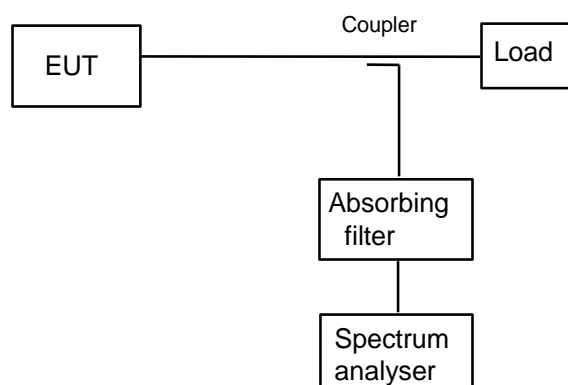

Figure 4: Test arrangement - on-axis spurious radiation measurements at the antenna flange

- a) The test arrangement shall be as shown in figure 4. In order to protect the Spectrum Analyser while ensuring the necessary measurement accuracy, particularly close to the carrier, if an absorbing filter is used it shall be tuned to the transmit carrier frequency.
- b) The EUT shall transmit one modulated carrier continuously, or at its maximum burst rate where applicable, centred on a frequency as close to the lower limit of the operating frequency band of the EUT as possible. The EUT shall be operated at the highest normal operating EIRP. The frequency range 14,00 GHz to 14,50 GHz shall be investigated.
- c) Due to the proximity of the carrier the spectrum analyser resolution bandwidth shall be set to a measurement bandwidth of 3 kHz, or as close as possible. If the measurement bandwidth is different from the specified measurement bandwidth, a bandwidth correction factor shall be performed for noise-like wideband spurious radiation.
- d) To obtain the on-axis spurious EIRP, the antenna transmit gain shall be added to any figure obtained in the above measurement and any correction or calibration factor summated with the result. The antenna gain shall be as measured in clause 6.3.3.2 at the closest frequency to the spurious frequency.
- e) The tests in b) to d) shall be repeated with a transmit frequency in the centre of the operating frequency band.
- f) The tests in b) to d) shall be repeated with a transmit frequency as close to the upper limit of the operating frequency band of the EUT as possible.
- g) The test shall be repeated in the carrier-off state.
- h) The test shall be repeated in the "transmission disabled state".

6.2.1.2.3 Method of measurement with a test antenna

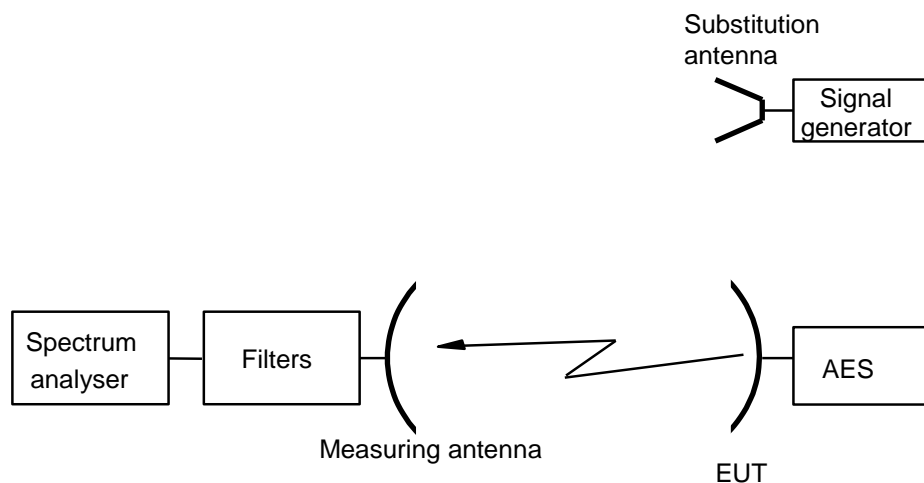

Figure 5: Test arrangement-on-axis spurious radiation measurements for an EUT with antenna

- a) The test arrangement shall be as shown in figure 5.
- b) The EUT shall be installed such that the LRUs are at a height between 0,5 m and 1,0 m on a turntable. If there are more than one LRU in the EUT, they shall be separated by 1 m to 2 m. The interconnection cable shall be maintained by non-conductive means at a height between 0,5 m and 1,0 m.
- c) The spectrum analyser resolution bandwidth shall be set to the specified measuring bandwidth or as close as possible. If the resolution bandwidth is different from the specified measuring bandwidth, a bandwidth correction factor shall be performed for noise-like wideband spurious radiation.
- d) The EUT shall transmit one modulated carrier continuously, or at its maximum burst rate where applicable, centred on a frequency as close to the lower limit of the operating frequency band of the EUT as possible. The EUT shall be operated at $EIRP_{max}$. The frequency range 14,00 GHz to 14,50 GHz shall be investigated and each spurious frequency shall be noted.

- e) Due to the proximity of the carrier the spectrum analyser resolution bandwidth shall be set to a measurement bandwidth of 3 kHz, or as close as possible. If the measurement bandwidth is different from the specified measurement bandwidth, a bandwidth correction factor shall be performed for noise-like wideband spurious radiation.
- f) The measuring antenna shall be positioned at a distance from the EUT (e.g. 3 m, 5 m, 10 m) relevant to the applied test site and shall be aligned with the EUT antenna for the transmit frequency. The measuring antenna shall be adjusted in height, while the EUT is in the appropriate carrier condition, for a maximum response on the associated spectrum analyser at each spurious frequency previously identified, this response level shall be noted. The adjustment in height of the measuring antenna does not apply when an anechoic chamber is being used.
- g) The EUT shall be replaced by a representative substitution antenna to which is connected a signal generator. The main beam axes of the measuring and substitution antennas shall be aligned. The distance between these antennas shall be the distance determined under test f).
- h) The substitution and measuring antennas shall be aligned in the polarization that produced the largest response between the EUT and the test antenna.
- i) The output of the generator shall be adjusted so that the received level is identical to that of the previously noted largest spurious radiation.
- j) The output level of the signal generator shall be noted. The EIRP of the on-axis spurious radiation is the sum, in dB, of the signal generator output plus the substitution antenna isotropic gain minus the interconnection cable loss.
- k) The tests in d) to j) shall be repeated with a transmit frequency in the centre of the operating frequency band.
- l) The tests in d) to j) shall be repeated with a transmit frequency as close to the upper limit of the operating frequency band of the EUT as possible.
- m) The test shall be repeated in the carrier-off state.
- n) The test shall be repeated in the "transmission disabled state" state.

6.3 Off-axis EIRP emissions density in the nominated bandwidth for 14 GHz AES and the power flux-density resulting from the 13 GHz AES towards any location in the geostationary-satellite orbit

6.3.1 14 GHz AES

6.3.1.1 General

Conformance shall be determined from:

- a) the measurement of the rms pointing accuracy;
- b) the measurement of the off-axis EIRP.

For the measurement of the off-axis EIRP, the EUT shall be either with or without its antenna:

- For AES equipment with passive antenna and for which measurements at the antenna flange are possible and agreed by the manufacturer, the EUT shall be without the antenna. The test shall be performed in three stages:
 - a) the measurement of the transmitter output power density (dBW/40 kHz);
 - b) the measurement of the antenna transmit gain (dBi);
 - c) the measurement of the antenna transmit radiation patterns (dBi).

- For AES equipment with active antenna or with passive antenna and for which measurements at the antenna flange are not possible or not agreed by the manufacturer, the EUT shall be fitted with the antenna. The test shall be performed in three stages:
 - a) the measurement of the maximum EIRP density per 40 kHz ratio relative to the EIRP (dBc/40 kHz);
 - b) the measurement of the maximum on-axis EIRP (dBW);
 - c) the measurement of the antenna transmit radiation patterns (dBi).

6.3.1.2 rms antenna pointing accuracy

6.3.1.2.1 Method of measurement



Figure 6: Test arrangement - rms pointing accuracy

- a) The equipment shall be arranged as shown in figure 6 at a distance between the STE and EUT such that the two antennas are in the far field of each other, with the EUT main beam set away from the STE. The beam Zn-angle and the beam Az-angle shall be set to 0°.
- b) The level of the signal radiated by the STE shall be adjusted so that the EUT receives a power density corresponding to the signal to noise ratio ~~declared by~~ specified for the manufacturer GSO Satellite Network. This power density shall be representative of those expected for 95 % of the AES within the network and typically will be 2 dB above the edge of coverage figures for which the AES is designed to operate.
- c) The EUT shall be switched-on and allow the EUT to acquire the pointing position towards the STE.
- d) ~~The pointing error shall be measured five times and recorded. The method of measurement to be used~~ pointing error shall be agreed the angle between the manufacturer line connecting the EUT and the test house STE and the line in the direction of the main beam of the EUT at the time EUT acquired the signal transmitted by the STE.
- e) The rms value of this pointing error shall be calculated with the above 5 measurements X_i :

$$rms\ value = \sqrt{\frac{1}{5} \times \sum_{i=1}^{i=5} X_i^2}$$

- f) The EUT shall be switched-off.
- g) The EUT shall be repointed to cause a change in main beam pointing angle of at least ~~60 degrees~~ 60 degrees.
- h) The tests in c) to f) shall be repeated 8 more times.
- i) The value of rms pointing accuracy shall be taken to be the largest value of the 9 rms values recorded.

6.3.1.3 Measurement of the off-axis EIRP without the antenna

6.3.1.3.1 Transmitter output power density

6.3.1.3.1.0 General

For purpose of the test, the EUT comprises all of the equipment (Installable Equipment; IE) noted up to the antenna flange:

- the EME;
- the IME;
- a connection cable between IME and EME unit;
- the necessary power supply cables and any other cable ensuring a proper functioning of the terminal.

Where the EUT is so designed that it is not normally possible to make a direct connection to the feed at the antenna flange, or connecting point, the manufacturer shall provide a means of so doing specifically for the test AES.

6.3.1.3.1.1 Method of measurement

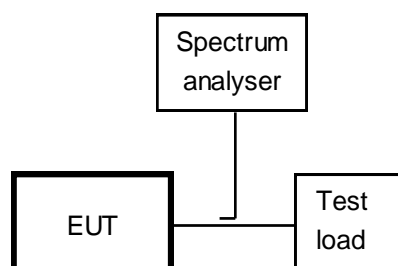

Figure 7: Test arrangement - transmit output power density measurement

- a) The EUT shall be connected to a test load as shown in figure 7.
- b) The test be carried out with the transmit signal of the operational waveform which carries a pseudorandom data stream, the maximum power density supplied to the antenna flange shall be measured in dBW/40 kHz. The coupling factor of the test coupler at the test frequency and the attenuation of any necessary waveguide adapter shall be taken into account. The resolution bandwidth of the spectrum analyser shall be set as close as possible to the specified measuring bandwidth. If the resolution bandwidth is different from the specified bandwidth then a bandwidth correction factor shall be performed.

6.3.1.3.2 Antenna transmit gain

6.3.1.3.2.1 General

For the purpose of the present document, the antenna transmit gain is defined as the ratio, expressed in decibels, of the power that would have to be supplied to the reference antenna, i.e. an isotropic radiator isolated in space, to the power supplied to the antenna being considered, so that they produce the same field strength at the same distance in the same direction. Unless otherwise specified the gain is for the direction of maximum radiation.

For the purpose of this test the EUT is defined as that part of the AES that comprises the antenna and its flange. The EUT includes an enclosure of equal weight/distribution to any electrical equipment normally housed within the antenna ~~(see clause 6.3.3.1 regarding this requirement).~~

6.3.1.3.2.2 Test site

This test shall be performed on either an outdoor far-field test site or compact test range. However, if the near-field scanner technology to convert near-field measurements to far-field results is proven ~~and sufficiently accurate~~ to be within measurement uncertainty given in annex C by reference to tests taken in ~~both regions~~ far field region then antenna measurements may be taken in the near field.

6.3.1.3.2.3

Method of measurement

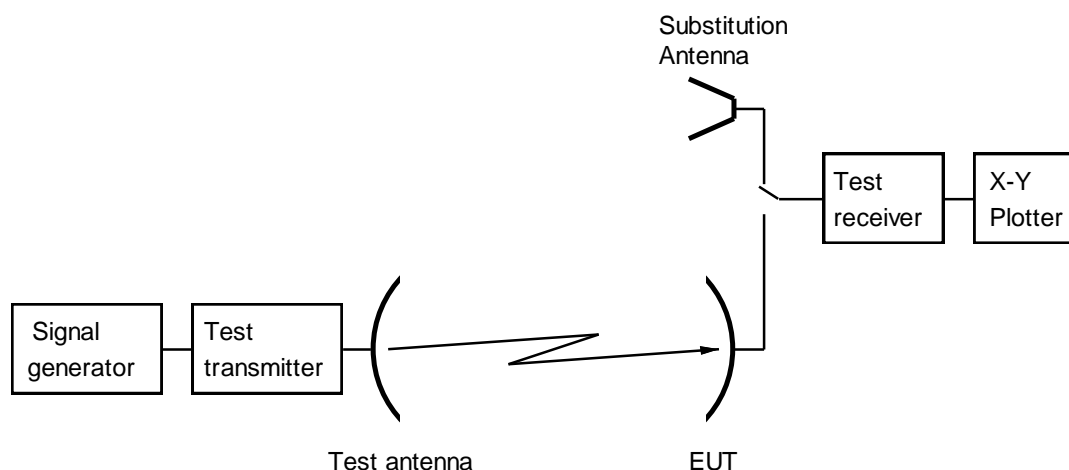

Figure 8: Test arrangement - antenna transmit gain measurement

- a) The test arrangement shall be as shown in figure 8 with the EUT connected to the test receiver. A signal proportional to the angular position from the servomechanism shall be applied to the X-axis and the signal level from the test receiver shall be applied to the Y-axis of the plotter.
- b) The main beam axis shall be pointed horizontal towards the STE.
- c) The initial E-plane of the test signal radiated by the test transmitter through its antenna shall be horizontal. The EUT main beam axis shall be aligned with the main beam axis of the test transmitter. The EUT antenna or its polarizer shall be rotated around its main beam axis such that its E-plane coincides with the E-plane of the test transmitter.
- d) After any change of the E-plane of the test signal, the EUT antenna shall be rotated around its main beam axis such that its E-plane coincides with the E-plane of the test transmitter.
- e) The frequency of the test signal shall be set 5 MHz above the bottom of the lowest frequency band ~~declared~~ specified by the manufacturer.
- f) The EUT shall be aligned to maximize the received signal and the X-Y plotter adjusted to give the maximum reading on the chart.
- g) The EUT shall be driven in azimuth in one direction through 10°.
- h) The pattern measurement is then obtained by driving the EUT in azimuth back through boresight to 10° the other side with the plotter recording the results.
- i) The EUT shall be replaced by the substitution antenna and the received signal level maximized.
- j) This level shall be recorded on the X-Y plotter.
- k) The substitution antenna shall be driven in azimuth as in f) and g).
- l) The gain of the EUT shall be calculated from:

$$G_{\text{EUT}} = L_1 - L_2 + C$$

where:

- G_{EUT} is the gain of the EUT (dBi);
- L_1 is the level obtained with the EUT (dB);
- L_2 is the level obtained with the substitution antenna (dB);
- C is the calibrated gain of the substituted antenna at the test frequency (dBi).

- m) The tests in e) to l) shall be repeated with the frequency changed to the middle of the lowest frequency band ~~declared~~specified by the manufacturer.
- n) The tests in e) to l) shall be repeated with the frequency changed to 5 MHz below the top of the lowest frequency band ~~declared~~specified by the manufacturer.
- o) The tests in d) to n) may be performed simultaneously.
- p) The tests in c) to p) shall be repeated with the E-plane vertical.
- q) The tests in c) to p) shall be repeated with the E-plane +45° to the horizontal plane.
- r) The tests in c) to p) shall be repeated with the E-plane -45° to the horizontal plane.
- s) The tests in b) to r) shall be repeated for all frequency bands ~~declared~~specified by the manufacturer.

6.3.1.3.3 Antenna transmit radiation patterns

6.3.1.3.3.1 General

For the purpose of the present document, the antenna transmit radiation patterns are diagrams relating field strength to direction relative to the pointing angle of the antenna at a constant large distance from the antenna.

For the purpose of this test the EUT is defined as that part of the AES which comprises the antenna and its flange. The antenna includes the parabolic reflector, feed, support struts and an enclosure of equal weight/distribution to any electrical equipment normally housed with the feed at the antenna focal point (~~see clause 6.3.3.1 regarding this requirement~~).

6.3.1.3.3.2 Test site

This test shall be performed on either an outdoor far-field test site or compact test range. However, if the near-field scanner technology to convert near-field measurements to far-field results is proven ~~and sufficiently accurate to be~~ within measurement uncertainty given in annex C by reference to tests taken in ~~both regions~~ far field region then antenna measurements may be taken in the near field.

6.3.1.3.3.3 Method of measurement

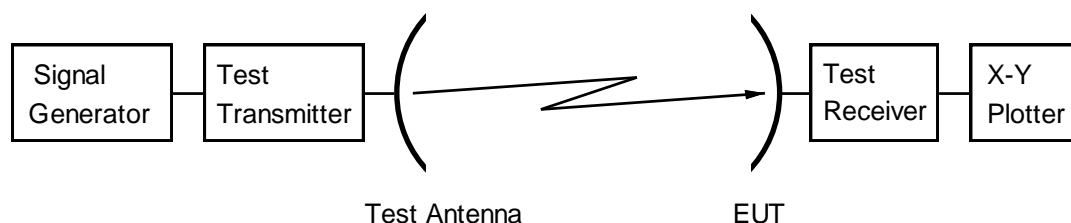

Figure 9: Test arrangement - antenna transmit radiation pattern measurement

- a) The test arrangement shall be as shown in figure 9 with the EUT connected to the test receiver. A signal proportional to the angular position from the servomechanism shall be applied to the X-axis and the signal level from the test receiver shall be applied to the Y-axis of the plotter.
- b) The main beam axis shall be pointed horizontal towards the STE.
- c) The initial E-plane of the test signal radiated by the test transmitter through its antenna shall be horizontal. The EUT main beam axis shall be aligned with the main beam axis of the test transmitter. The EUT antenna or its polarizer shall be rotated around its main beam axis such that its E-plane coincides with the E-plane of the test transmitter.
- d) After any change of the E-plane of the test signal, the EUT antenna shall be rotated around its main beam axis such that its E-plane coincides with the E-plane of the test transmitter.

- e) The frequency of the test signal shall be set 5 MHz above the bottom of the lowest frequency band ~~declared~~specified by the manufacturer.
- f) The EUT shall be aligned to maximize the received signal and the X-Y plotter adjusted to give the maximum reading on the chart.
- g) The EUT shall be driven in azimuth to -180° .
- h) The transmit pattern measurement is then obtained by driving the EUT in azimuth through from -180° to $+180^\circ$ with the plotter recording the results. Measurements may be excluded where the radiation pattern from the antenna is fully blocked by the aircraft fuselage for the models ~~declared~~specified by the manufacturer. Exclusions shall be noted in the test report.
- i) The tests in d) to h) shall be repeated with the frequency changed to the middle of the lowest frequency band ~~declared~~specified by the manufacturer.
- j) The tests in d) to h) shall be repeated with the frequency changed to 5 MHz below the top of the lowest frequency band ~~declared~~specified by the manufacturer.
- k) The tests in d) to j) may be performed simultaneously.
- l) The tests in d) to k) shall be repeated with the E-plane being vertical.
- m) The tests in d) to k) shall be repeated with the E-plane at $+\alpha$ to the vertical plane. α is defined as the worst-case angle ($^\circ$) between the horizontal plane and the geostationary orbital arc, as seen from the range of latitudes as ~~declared~~specified by the manufacturer.
- n) The tests in d) to k) shall be repeated with the E-plane at $-\alpha$ to the horizontal. α is as defined in m).
- o) The tests in c) to n) shall be repeated for all frequency bands ~~declared~~specified by the manufacturer.

6.3.1.3.4 Computation of results

The results shall be computed by producing a "mask" to the specified limits with the reference level being equal to the sum of the transmitter output power density and the on-axis gain of the antenna. The mask shall be a function of ϕ and shall take account of the value $\delta\phi$ equal to the rms of the measured pointing accuracy. This reference shall then be placed on the maximum point of the plot obtained from the transmit radiation pattern measurement, so as to ascertain that the off-axis EIRP density is within the mask, and thus conforming to the specification.

6.3.1.4 Measurement of the off-axis EIRP with the antenna

6.3.1.4.1 General

The requirements set out in clauses 6.1.1 to 6.1.3-1.2 for the measurements above 1 000 MHz shall apply.

6.3.1.4.2 Maximum EIRP density per 40 kHz ratio relative to the EIRP

6.3.1.4.2.0 General

For purpose of the test, the EUT shall be the AES fitted with its antenna.

6.3.1.4.2.1 Method of measurement

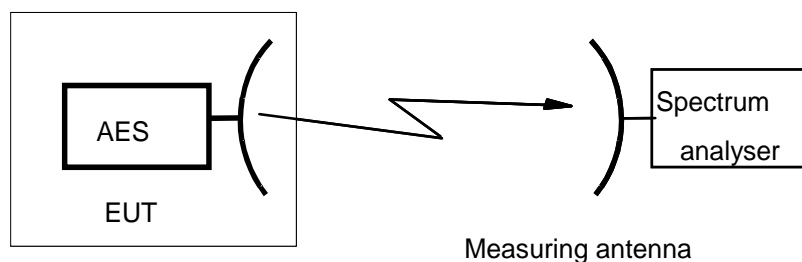

Figure 10: Test arrangement - radiated power density measurement

- The test arrangement shall be as shown in figure 10, both antennas being in line of sight of each other.
- The test be carried out with the transmit signal of the operational waveform which carries a pseudorandom data stream. The transmission shall be continuous where possible.
- The resolution bandwidth of the spectrum analyser shall be set larger but as close as possible to the Bo of the transmitted signal. The total power P1 received shall be measured in dBW.
- The resolution bandwidth of the spectrum analyser shall be set as close as possible to the specified measuring bandwidth: 40 kHz. If the resolution bandwidth is different from the specified bandwidth then a bandwidth correction factor shall be performed. The maximum value P2 of the power received in any 40 kHz bandwidth over the Bo shall be measured in dBW.
- The maximum EIRP density per 40 kHz ratio relative to the EIRP, in dBc/40 kHz, is the difference (P1 - P2).

6.3.1.4.3 Maximum on-axis EIRP

6.3.1.4.3.1 General

For purpose of the test, the EUT is the AES fitted with its antenna.

The distance between the EUT or the substitution antenna and the measuring antenna shall be such that the radiating near-field of each antenna shall not overlap with that of the other. The larger radiating near-field of the EUT and substitution antenna shall be used to determine the minimum distance between the EUT and measuring antenna in the first instance.

6.3.1.4.3.2 Test site

This test shall be performed on either an outdoor far-field test site or compact test range. However, if the near-field scanner technology to convert near-field measurements to far-field results is proven ~~and sufficiently accurate to be~~ within measurement uncertainty given in annex C by reference to tests taken in ~~both regions~~ far field region then antenna measurements may be taken in the near field.

6.3.1.4.3.3

Method of measurement

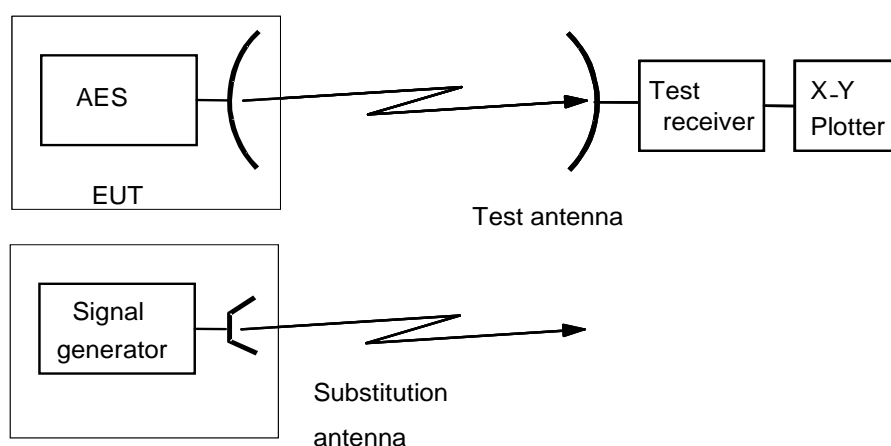

Figure 11: Test arrangement - maximum on-axis EIRP received measurement

- a) The test arrangement shall be as shown in figure 11, both antennas being in line of sight of each other. A signal proportional to the angular position from the servomechanism shall be applied to the X-axis and the signal level from the test receiver proportional to the power received in dBW shall be applied to the Y-axis of the plotter.
- b) The test be carried out with the EUT transmitting the operational waveform signal, at maximum power, which carries a pseudorandom data stream. The transmission shall be continuous where possible.
- c) The resolution bandwidth of the spectrum analyser shall be set larger but as close as possible to the B_0 of the transmitted signal.
- d) The ground plane axis shall be pointed horizontal towards the STE. The beam Z_n -angle and the beam Az -angle shall be set to 0° .
- e) The initial E-plane of the test signal radiated by the EUT through its antenna shall be horizontal. The test receiver antenna main beam axis shall be aligned with the main beam axis of the EUT antenna. The test receiver antenna or its polarizer shall be rotated around its main beam axis such that its E-plane coincides with the E-plane of the EUT.
- f) After any change of the E-plane of the test signal, the test receiver antenna shall be rotated around its main beam axis such that its E-plane coincides with the E-plane of the EUT.
- g) The frequency of the test signal shall be set $0,5 \times B_0$ above the bottom of the lowest frequency band ~~declared~~ specified by the manufacturer.
- h) The EUT shall be aligned to maximize the received signal and the X-Y plotter adjusted to give the maximum reading on the chart.
- i) The EUT shall be driven in azimuth in one direction through 10° .
- j) The pattern measurement is then obtained by driving the EUT in azimuth back through boresight to 10° the other side with the plotter recording the results.
- k) The EUT shall be replaced by the signal generator connected to a calibrated antenna (a substitution antenna), transmitting a carrier at a frequency equal to the EUT carrier frequency. The received signal level shall be maximized.
- l) This level shall be recorded on the X-Y plotter.
- m) The signal generator with the substitution antenna shall be driven in azimuth as in h) and j).
- n) The EIRP of the signal radiated by the EUT shall be calculated from:

$$EIRP_{EUT} = L_1 - L_2 + G + P$$

where:

- $EIRP_{EUT}$ is the EIRP of the signal radiated by the EUT (dBW), in the considered direction;
 - L_1 is the level obtained with the EUT (dBW), in the considered same direction;
 - L_2 is the level obtained with the signal generator with the substitution antenna (dBW);
 - G is the calibrated gain of the substitution antenna at the test frequency (dBi);
 - P is the power produced by the signal generator at the flange of the substitution antenna (dBW).
- o) The tests in h) to n) shall be repeated with the frequency changed to the middle of the lowest frequency band ~~declared~~specified by the manufacturer.
 - p) The tests in h) to n) shall be repeated with the frequency changed to $0,5 \times B_o$ below the top of the lowest frequency band ~~declared~~specified by the manufacturer.
 - q) The tests in h) to p) may be performed simultaneously.
 - r) The tests in h) to q) shall be repeated with the E-plane vertical.
 - s) The tests in h) to q) shall be repeated with the E-plane at $+45^\circ$ to the horizontal plane.
 - t) The tests in h) to q) shall be repeated with the E-plane at -45° to the horizontal plane.
 - u) For an active antenna the tests in h) to t) shall be repeated with the beam Z_n angle increased in 15° increments up to the maximum beam Z_n angle ~~declared~~specified by the manufacturer when maximum EIRP variation is expected with the beam Z_n angle.
 - v) For an active antenna the tests in h) to u) shall be repeated with the beam A_z angle increased in 45° increments when maximum EIRP variation is expected with the beam A_z angle.
 - w) The tests in g) to v) shall be repeated for all frequency bands ~~declared~~specified by the manufacturer.
 - x) The maximum on-axis EIRP of the signal radiated by the EUT is the maximum value of the values calculated in step n).

6.3.1.4.4 Antenna transmit radiation patterns

6.3.1.4.4.1 General

For the purpose of the present document, the antenna transmit radiation patterns are diagrams relating field strength to direction relative to the pointing angle of the antenna at a constant large distance from the antenna.

For purpose of the test, the EUT shall be the AES fitted with its antenna.

The distance between the EUT or the substitution antenna and the measuring antenna shall be such that the radiating near-field of each antenna shall not overlap with that of the other. The larger radiating near-field of the EUT and substitution antenna shall be used to determine the minimum distance between the EUT and measuring antenna in the first instance.

6.3.1.4.4.2 Test site

This test shall be performed on either an outdoor far-field test site or compact test range. However, if the near-field scanner technology to convert near-field measurements to far-field results is proven ~~and sufficiently accurate to be~~ within measurement uncertainty given in annex C by reference to tests taken in ~~both regions~~ far field region then antenna measurements may be taken in the near field.

6.3.1.4.4.3 Method of measurement

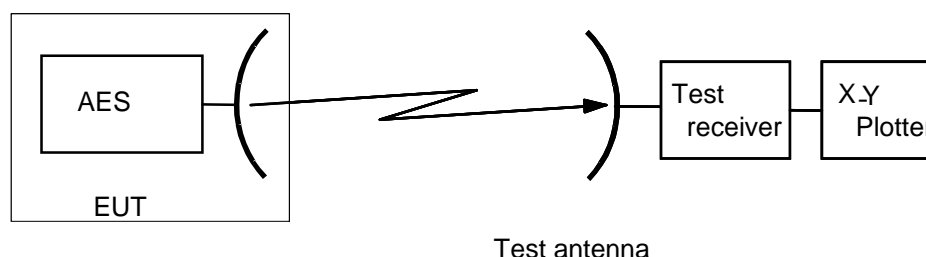

Figure 12: Test arrangement - antenna transmit radiation pattern measurement

- a) The test arrangement shall be as shown in figure 12, both antennas being in line of sight of each other. A signal proportional to the angular position from the servomechanism shall be applied to the X-axis and the signal level from the test receiver proportional to the power received in dBW shall be applied to the Y-axis of the plotter.
- b) The test be carried out with the EUT transmitting the operational waveform signal, which carries a pseudorandom data stream. The transmission shall be continuous where possible.
- c) The resolution bandwidth of the spectrum analyser shall be set larger but as close as possible to the Bo of the transmitted signal.
- d) The antenna main beam axis shall be pointed horizontal towards the STE. The beam Zn-angle and the beam Az-angle shall be set to 0°.
- e) The initial E-plane of the test signal radiated by the EUT through its antenna shall be horizontal. The test receiver antenna main beam axis shall be aligned with the main beam axis of the EUT. The test receiver antenna or its polarizer shall be rotated around its main beam axis such that its E-plane is coincides with the E-plane of the EUT.
- f) After any change of the E-plane of the EUT test signal, the test receiver antenna shall be rotated around its main beam axis such that its E-plane is coincides with the E-plane of the EUT.
- g) The frequency of the EUT test signal shall be set 0,5 x Bo above the bottom of the lowest frequency band ~~declared~~ specified by the manufacturer.
- h) The EUT shall be aligned to maximize the received signal and the X-Y plotter adjusted to give the maximum reading on the chart.
- i) The EUT shall be driven in azimuth to -180°.
- j) The transmit pattern measurement is then obtained by driving the EUT in azimuth through from -180° to +180° with the plotter recording the results. Measurements may be excluded where the radiation pattern from the antenna is fully blocked by the aircraft fuselage for the models ~~declared~~ specified by the manufacturer. Exclusions shall be noted in the test report.
- k) The tests in h) to j) shall be repeated with the frequency changed to the middle of the lowest frequency band ~~declared~~ specified by the manufacturer.
- l) The tests in h) to j) shall be repeated with the frequency changed to 0,5 x Bo below the top of the lowest frequency band ~~declared~~ specified by the manufacturer.
- m) The tests in h) to l) may be performed simultaneously.
- n) The tests in f) to m) shall be repeated with the E-plane vertical.

- o) The tests in f) to m) shall be repeated with the E-plane at $+\alpha$ to the horizontal plane. α is defined as the worst-case angle ($^\circ$) between the horizontal plane and the geostationary orbital arc, as seen from the range of latitudes as ~~declared~~specified by the manufacturer.
- p) The tests in f) to m) shall be repeated with the E-plane at $-\alpha$ to the horizontal plane. α is as defined in k).
- q) For an active antenna, the tests in f) to p) shall be repeated with beam Zn angle increased in 15° increments up to the maximum beam Zn angle ~~declared~~specified by the manufacturer when maximum EIRP variation is expected with beam Zn angle.
- r) For an active antenna, the tests in f) to q) shall be repeated with the beam Az angle increased in 45° increments when maximum EIRP variation is expected with the beam Az angle.
- s) The tests in f) to r) shall be repeated for all frequency bands ~~declared~~specified by the manufacturer.

6.3.1.4.5 Computation of results

The results shall be computed by producing a "mask" to the specified limits with the reference level being equal to the sum of the transmitter on-axis EIRP (measured in clause 6.3.1.4.2) and the ratio between the maximum EIRP density per 40 kHz ratio to the EIRP (measured in clause 6.3.1.4.3). The mask shall be a function of ϕ and shall take account of the value $\delta\phi$ equal to the rms of the measured pointing accuracy. This reference shall then be placed on the maximum point of the plot obtained from the transmit radiation pattern measurement, so as to ascertain that the off-axis EIRP density is within the mask, and thus conforming to the specification.

6.3.2 13 GHz AES

6.3.2.1 General

Conformance shall be determined from:

- a) the measurement of the off-axis EIRP at $9,9^\circ$ from the EUT antenna main beam axis;
- b) the assessment of power-flux density.

Off-axis EIRP at $9,9^\circ$ from the EUT antenna main beam axis shall be obtained from the results given by the clause 6.3.1.4.5 and computed for a reference bandwidth of 1 MHz. The assumption that the topocentric angle is 1,1 times of the geocentric angle is based on Recommendation ITU-R S.728-1 [i.8].

The power flux-density (Earth-to-space) under free space propagation conditions at an orbital position 9° from the target orbital position shall be assessed using the formulae below:

$$\text{power flux-density dB(W/(m}^2 \cdot \text{MHz))} = (\text{off-axis EIRP at } 9,9^\circ \text{ from the AES antenna main beam axis in 1 MHz})/4\pi d^2$$

where d is the distance between the earth station and the position in the GSO $9,9^\circ$ away from the AES antenna main beam axis - assumed to be 35 306 000 m.

6.4 Power Flux Density Test

6.4.1 14 GHz AES

6.4.1.1 General

Tests consist in:

- 1) Verification of specification 1: mode of PFD limitation (see clause 6.4.2).
- 2) Verification of specification 2: Location where to limit the PFD (see clause 6.4.1.3).

- 3) Verification of specification 3: PFD limitation (see clause 6.4.1.4):
 - a) Measurement of the radiation pattern below the aircraft fuselage (see clause 6.4.1.4.1).
 - b) Measurement of on-axis EIRP as a function of altitude (see clause 6.4.1.4.2).
 - c) Computation of the power flux density at the surface of the Earth (see clause 6.4.1.4.3).
- 4) Verification of specification 4: Fault conditions (see clause 6.4.1.5).

The ~~applicant~~manufacturer shall provide a STE, with the necessary functionality to perform the required tests. The STE may be a NCF, or an equipment simulating some functions of the NCF, for the purpose of the tests, e.g. the transmission of test messages and the display of the messages received and transmitted.

Within that clause 6.4, the aircraft parameters are the necessary parameters provided by the aircraft and used for the determination of the transmissions parameters.

6.4.1.2 Verification of specification 1: Mode of PFD limitation

~~The applicant~~Following shall ~~declare~~be as specified for the GSO Satellite Network:

- the modes of limitation which are implemented within the AES, at least one; and
- the AES interfaces involved in the PFD limitation as specified in specification 1 of clause 4.2.6 with their characteristics.

These ~~declared~~ AES interfaces shall be in accordance with the user documentation.

~~Unless declared by the applicant the~~The above information, unless specified for the GSO Satellite Network, shall be taken from the user documentation.

6.4.1.3 Verification of specification 2: Location where to limit the PFD

~~The applicant~~Following shall ~~demonstrate by documentary evidence~~be as specified for the GSO Satellite Network:

- ~~that with the declared NCF AES interfaces~~specified interfaces exist for determining Location 1 and relevant aircraft AES interfaces the NCFLocation 2, and limiting PFD produced at the surface of the AES are able to determine, with the accuracy declared by the applicant, the locations where to limit the PFD as required in specification 2earth as specified in clause 4.2.6.1.1.3;

~~The applicant shall demonstrate:~~

- ~~that the declared interfaces exist;~~
- ~~that the declared~~specified relevant parameters for the transmission parameter determination are transmitted by the AES towards the NCF or the STE simulating a NCF; and
- that the ~~declared~~ transmission parameters received from the NCF are effectively received from the NCF or from the STE simulating a NCF.

For an AES which determines partially where to limit the PFD, based on its location, the ~~applicant~~manufacturer shall demonstrate:

- that the AES is able to determine where to limit the PFD when the values of the ~~declared~~ relevant parameters collected by the AES and the transmission parameters received from the NCF or from the STE are modified.

The test configuration described in clause 6.4.1.5 for the verification of specification 4 shall apply.

6.4.1.4 Verification of specification 3: PFD limitation

6.4.1.4.1 Measurement of the antenna radiation pattern below the aircraft fuselage

6.4.1.4.1.1 General

In this test the EUT is mounted on a ground plane that is representative of an aircraft fuselage section. The ground plane shall have a diameter equal to the smallest fuselage diameter of the range of aircraft models ~~declared~~specified by the manufacturer with which the EUT will operate. If required this test can be repeated with ground planes representative of each aircraft model ~~declared~~specified by the manufacturer.

One method for a test of the EUT is given below in clause 6.4.1.4.1.3. It is the responsibility of the equipment manufacturer to define a detailed test methodology for his AES system.

6.4.1.4.1.2 Test site

Test sites, far-field or compact range, shall be limited to those that adhere to the standards and definitions provided in IEEE STD 149™ [3]. The test site shall be capable of substitution method gain measurements as defined by the above IEEE standard.

6.4.1.4.1.3 Test method procedure

This test measures the antenna radiation pattern on a cross section perpendicular to the aircraft longitudinal axis, with the AES mounted on the aircraft fuselage.

All range setup and tests shall be undertaken with the EUT transmitting at $EIRP_{max}$.

The following setup and test pertains to each frequency and polarization to be measured. All EUT measurements are to have the radome in place:

- a) A typical fuselage roll plane test arrangement shall be as shown in figure 13. This figure shows an AES antenna mounted on a metallic fuselage section of an aircraft. The fuselage section is mounted in the compact range such that it can be rotated through 360° to allow the measurement of the radiation pattern below the fuselage section.
- b) Range receiver linearity and peak level shall be set using an appropriate calibrated antenna.
- c) Range receiver dynamic range shall be greater than 120 dB with linearity demonstrated 30 dB above the peak standard level.
- d) A reference level gain pattern shall be recorded through the beam peak.
- e) The calibrated antenna shall be removed from the test set-up and replaced with the fuselage section, EUT, and radome. No change to the range configuration other than the replacement of the calibrated antenna with the fuselage section, EUT, and radome is permitted.
- f) Set the antenna Zn-angle and the beam Zn-angle of the EUT to the maximum specified angle, θ_{min} as ~~declared~~specified for the ~~manufacturer~~GSO Satellite Network.
- g) Record the complete 360° EUT roll plane radiation pattern.
- h) Adjust/normalize the received EUT radiation pattern level based on the difference between the measured reference gain standard level and the certified reference gain level.

Repeat a) through h) at each desired frequency and emitted polarization.

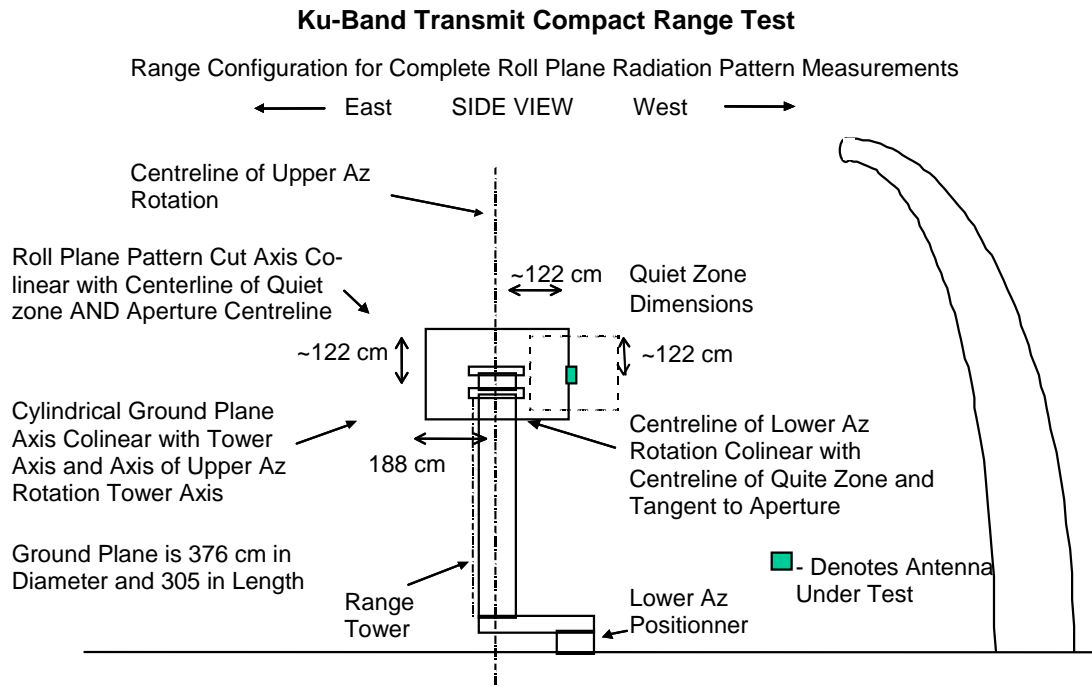

Figure 13: An example of a test set-up for measuring the roll plane radiation pattern beneath the fuselage of an aircraft

6.4.1.4.2 Measurement of on-axis EIRP as a function of altitude

6.4.1.4.2.1 General

In this test the STE is used to simulate the operation of the AES within line-of-sight of an operating FS (ITU Radio Regulations [i.5]_{footnotes 5.508a, 5.509a, 5.505, and 5.508-[i.5])}) and/or a radio astronomy site (14,47 GHz to 14,50 GHz). The test will measure EIRP as a function of altitude. In cases where the NCF issues PFD limitation commands, STE will also be used to simulate the NCF.

If the EUT is an AES that has been modified by the manufacturer for these tests then full documentation of such modification(s) shall be provided to prove that the modification(s) will simulate the required test condition.

6.4.1.4.2.2 ~~Test site~~Void

~~There are no requirements for the test site to be used for this test.~~

6.4.1.4.2.3 Method of measurement with a test antenna

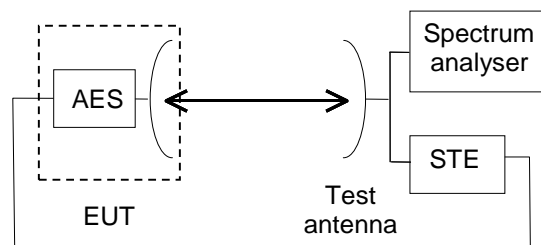

Figure 14: Test arrangement for measurement of on-axis EIRP as a function of altitude

- The test arrangement shall be as shown in figure 14.
- The resolution bandwidth of the spectrum analyser shall be set larger but as close as possible to the Bo of the transmitted signal.

- c) The STE shall be set to simulate AES operation at 1 km in altitude, or at the minimum ~~declared~~ operational altitude specified for the GSO Satellite Network, within line-of-sight of an operating FS, or a radio astronomy site.
- d) The EUT shall transmit one modulated carrier continuously at the minimal Bo ~~declared by the applicant~~ as specified for the GSO Satellite Network, or at its maximum burst rate where applicable. The transmit signal centre frequency shall be as close to the minimum operational frequency as ~~declared by~~ specified for the applicant GSO Satellite Network for compliance with the FS limitation in the band between 14,25 GHz and 14,50 GHz.
- e) The measuring antenna shall be positioned at a distance from the EUT (e.g. 3 m, 5 m, 10 m) relevant to the applied test site and shall be aligned with the EUT antenna for the transmit frequency.
- f) The tests in d) to e) shall be repeated with a transmit frequency in the centre of the operating frequency band.
- g) The tests in d) to e) shall be repeated with a transmit frequency as close to the upper limit of the operating frequency band of the EUT as possible.
- h) The tests in d) to g) shall be repeated with the simulated altitude successively set to 2 km, 4 km, 8 km, 12 km, if applicable.
- i) The tests in b) to h) shall be repeated with the nominated bandwidth set to the maximum Bo as ~~declared~~ specified for the applicant GSO Satellite Network.
- j) The tests in steps b) to i) shall be repeated with the transmit signal centre frequency centred, and as close to the upper limit of the band of operations as ~~declared by~~ specified for the operator GSO Satellite Network for operation with FS in the band between 14,25 GHz and 14,50 GHz.
- k) The tests in steps b) to i) shall be repeated with the transmit signal as close to the minimum operational frequency, centred at the centre frequency, and as close to the maximum operational frequency of the band of operations as ~~declared by~~ specified for the operator GSO Satellite Network for operation with RA in the band between 14,47 GHz and 14,50 GHz.
- l) The above test shall be repeated for protection of FS band between 14,00 GHz and 14,25 GHz. ~~These tests can be replaced by documentary evidence, based on the results provide for protection of the FS band between 14,25 GHz and 14,50 GHz.~~

6.4.1.4.3 Computation of the power flux density at the surface of the Earth

The PFD at the surface of the Earth shall be calculated as follows:

- 1) The EIRP pattern below the aircraft shall be computed for each transmit frequency and altitude tested in clause 6.4.2. This is done using the maximum on-axis EIRP spectral density measured in:
 - a) the 14,25 GHz to 14,50 GHz band with respect to FS requirements; and
 - b) the 14,47 GHz to 14,50 GHz band with respect to Radio Astronomy requirements;
 using the gain pattern below the aircraft measured in clause 6.4.1.
- 2) Then for each transmit frequency and altitude tested in clause 6.4.2, the PFD at the surface of the earth as a function of arrival angle shall be computed using the EIRP pattern below the aircraft (calculated above) for that test condition and the method of computing the PFD at the surface of the Earth described in annex D of Recommendation ITU-R M.1643 [5].

These computations shall take into account the inaccuracy on the locations where the PFD has to be limited.

NOTE: This inaccuracy is a function of the period of transmission of the location of the aircraft, of the maximum speed of the aircraft, of ~~its~~ maximum trajectory deviations, of the inaccuracy of the position measurements, on the time distribution within the network, of the transmissions delays, of the delays within successive buffers.

- 3) Finally, for each frequency and altitude tested, the resulting PFD at the surface of the earth as a function of arrival angle can be compared to the limits in ~~clauses~~ clause 4.2.6.2 and 4.2.6.3 1.1 to verify compliance.

6.4.1.5 Verification of specification 4: Fault conditions

6.4.1.5.1 Test Arrangement

The tests in this clause shall be performed either using the test setup as illustrated in figure 14, or with the AES installed on an airplane and a test NCF.

6.4.1.5.2 Test method

- 1) Uncompleted collection of the aircraft parameters:
 - a) The EUT shall be in the "Transmission enabled" state and shall be transmitting data.
 - b) The EUT shall require aircraft parameters through its command interface with the aircraft.
 - c) A fault condition on the collection of the transmission parameters shall be generated.
 - d) The EUT shall enter the "Transmission disabled" state within the time frame ~~declared by the applicant~~ specified for the GSO Satellite Network.

The events from a) to d) shall be displayed and verified with the oscilloscope and by measurement of the transmitted signal.

- 2) Uncompleted transmission of the aircraft state parameters by the EUT to the NCF:
 - a) The EUT shall be in the "Transmission enabled" state.
 - b) The EUT shall send a status message with the new aircraft state parameter(s) to the NCF or STE. Either this is done periodically or when the aircraft state parameter(s) change. In that second case the aircraft state parameter(s) shall be modified so that the EUT send a status message.
 - c) The EUT shall transmit status message with the aircraft state parameters, as ~~declared by~~ specified for the applicant GSO Satellite Network, to the NCF or STE.
 - d) The transmission of the status message by the EUT to the NCF or STE shall be interrupted.
 - e) The EUT shall enter the "Transmission disabled" state within the time frame ~~declared by~~ specified for the applicant GSO Satellite Network.

The events from a) to e) shall be displayed and verified with the oscilloscope or recorded command time.

~~If this test cannot be performed as specified above, this demonstration may be replaced by documentary evidences.~~

- 3) Transmission parameter not received or not correctly received from the NCF:
 - a) The EUT shall be in the "Transmission enabled" state.
 - b) The reception of transmission parameters messages from the NCF or STE shall be inhibited.
 - c) The EUT shall send a status message with the new aircraft state parameter(s) to the NCF or STE. Either this is done periodically or when the aircraft state parameter(s) change. In that second case the aircraft state parameter(s) shall be modified so that the EUT send a status message.
 - d) The EUT shall transmit the status message with the aircraft state parameters to the NCF or STE.
 - e) Without receiving from the NCF or STE the message with the transmission parameters within the time frame ~~declared by~~ specified for the applicant GSO Satellite Network the EUT shall enter the "Transmission disabled" state.

The events from a) to e) shall be displayed and verified with the oscilloscope and by measurement of the transmitted signal.

~~If this test cannot be performed as specified above, this demonstration may be replaced by documentary evidences.~~

6.4.2 13 GHz AES

6.4.2.1 Test Method

The NCF-AES interfaces intended to be used for continually monitoring and maintaining the PFD value of earth shall be used in the test. In this test the STE is used to simulate the operation of the EUT within PFD limits specified in clause 4.2.6.2.1 and also simulate a condition where such PFD limits are exceeded. The CC commands from the STE carrying necessary transmission parameters to the EUT in order to maintain the PFD limits on earth shall be verified according to the test method given in clause 6.5.5.1 e).

The transmission of the disable command via the CC commands by the STE to the EUT, when PFD limits on earth are exceeded, shall be verified according the test method given in clause 6.5.6.1 b).

6.5 Control and monitoring

6.5.0 General

If the EUT is an AES that has been modified by the manufacturer for these tests then full documentation of such modification(s) shall be provided to prove that the modification(s) will simulate the required test condition.

For the purpose of this test the EUT is defined as the AES either with or without its antenna connected.

The measurement of the EIRP spectral density shall be limited to within either the nominated bandwidth or a 10 MHz bandwidth centred on the carrier frequency, whichever is the greater.

6.5.1 Test arrangement

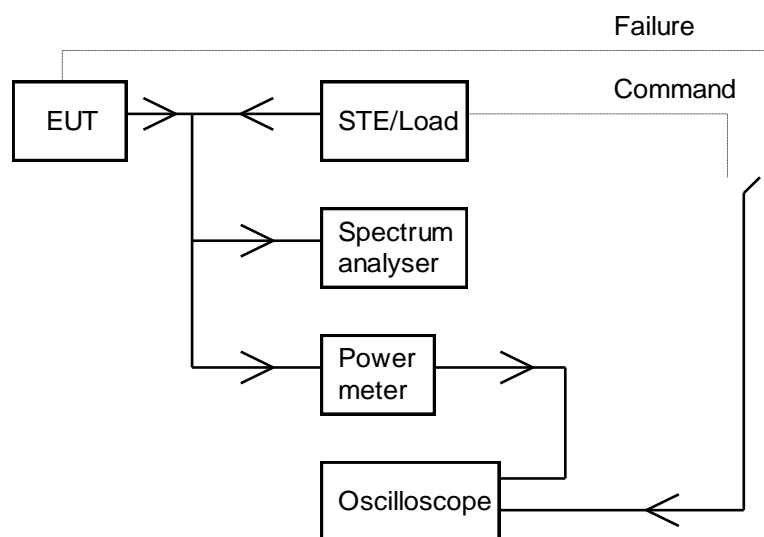

Figure 15: General test arrangement for control and monitoring tests for conducted measurements

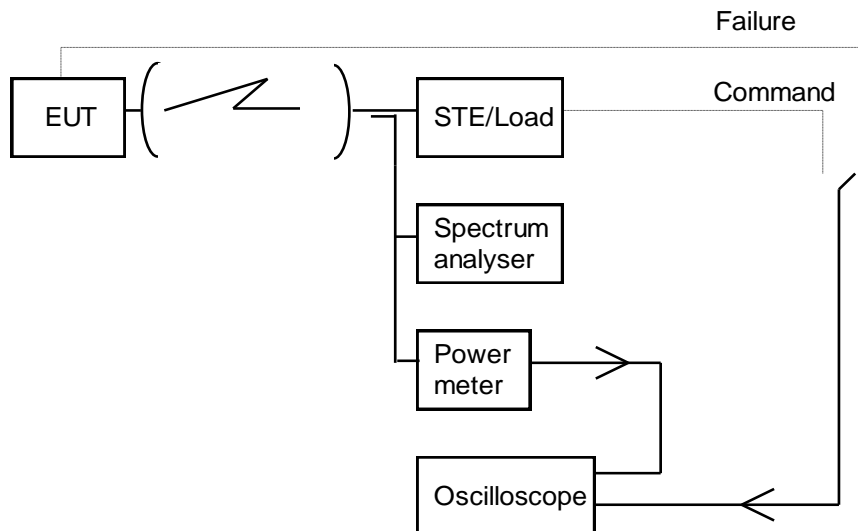

Figure 16: General test arrangement for control and monitoring tests for radiated measurements

The test arrangement shall be as shown in figures 15 or 16. The EUT shall be authorized to transmit and shall be in the carrier-on state at the commencement of each test. The dual trace storage oscilloscope shall monitor by measuring the time difference between the command, or failure, and the occurrence of the expected event (e.g. the transmission suppression). Alternatively, command messages may be automatically recorded and time stamped for comparison to the occurrence of the expected event. The power meter and spectrum analyser shall monitor the EUT output level.

6.5.2 Processor monitoring

6.5.2.1 Test method

- a) Each of the processors within the EUT shall, in turn, be caused to fail.
- b) Within 1 s of such failure the EUT shall cease to transmit as measured by the oscilloscope.
- c) The power meter and spectrum analyser shall be observed to ascertain that the transmissions have been suppressed.
- d) The failed processor shall be restored to normal working condition and the EUT shall be restored to normal working before the next processor shall be induced to fail.

6.5.3 Transmit subsystem monitoring

6.5.3.1 Test method

- a) The frequency generation subsystem shall be caused to fail in respect of:
 - 1) frequency stability;
 - 2) output.
- b) Within 6 s of such failure the EUT shall cease to transmit as measured by the oscilloscope.
- c) The power meter and spectrum analyser shall be observed to ascertain that the transmissions have been suppressed.
- d) The frequency generation subsystem shall be restored to normal working condition and the EUT shall be restored to normal working before the next induced failure.

6.5.4 Power-on/Reset

6.5.4.1 Test method

- a) The EUT shall be switched off and the STE shall not transmit the CC.
- b) The EUT shall be switched on.
- c) The EUT shall not transmit during and after switching-on, and shall enter the Transmission disabled state.

The events from a) to c) shall be displayed and verified with the oscilloscope and by measurement of the transmitted signal. If a manual reset function is implemented the following test shall be performed:

- d) The EUT shall be switched on and the STE shall transmit the CC.
- e) A call shall be initiated from the EUT and the EUT shall enter the carrier-on state.
- f) The reset function shall be initiated.
- g) The EUT shall enter the Transmission disabled state.

The event from e) to g) shall be displayed and verified with the oscilloscope or recorded command time and by measurement of the transmitted signal.

6.5.5 Control Channel (CC) reception

6.5.5.1 Test method

The following tests shall be performed:

- case where the CC has never been received by the EUT;
- case where the CC is lost by the EUT during a transmission period of a call;
- case where the CC is lost by the EUT during a period without transmission;
- case where the CC is being lost by the EUT and a call is initiated within the Time-Out period T1;
- case where the CC requests a change of transmission parameters to the EUT.

The Time-Out period T1 used in the tests shall be 30 s.

- a) Case where the CC has never been received by the EUT:
 - a1) The EUT shall be switched off and the STE shall not transmit the CC.
 - a2) The EUT shall be switched on.
 - a3) A call shall be initiated from the EUT.
 - a4) The EUT shall remain in the Transmission disabled state.

The events from a2) to a4) shall be displayed and verified with the oscilloscope or recorded command time and by measurement of the transmit signal.

- b) Case where the CC is lost by the EUT during a transmission period of a call:
 - b1) The EUT shall be switched-on and the STE shall transmit the CC.
 - b2) A call shall be initiated from the EUT.
 - b3) The STE shall stop transmitting the CC.
 - b4) Within T1 from b3), the EUT shall enter the Transmission disabled state.

The events from b2) to b4) shall be displayed and verified with the oscilloscope or recorded command time and by measurement of the transmitted signal.

- c) Case where the CC is lost by the EUT during a period without transmission:
 - c1) The EUT shall be switched on and the STE shall transmit the CC.
 - c2) The STE shall stop transmitting the CC.
 - c3) More than T1 later, a call shall be initiated from the EUT.
 - c4) The EUT shall remain in the Transmission disabled state.

The events from c2) to c4) shall be displayed and verified with the oscilloscope or recorded command time and by measurement of the transmitted signal.

- d) Case where the CC is being lost by the EUT and a call is initiated within the T1 period:
 - d1) The EUT shall be switched on and the STE shall transmit the CC.
 - d2) The STE shall stop transmitting the CC.
 - d3) Within the period T1 from d2), a call shall be initiated from the EUT.
 - d4) The EUT may transmit but within the T1 period the EUT shall enter the Transmission disabled state.

The events from d2) to d4) shall be displayed and verified with the oscilloscope or recorded command time and by measurement of the transmitted signal.

- e) Case where the CC requests a change of transmission parameters to the EUT:
 - e1) The EUT shall be on the Transmission enabled state.
 - e2) The STE shall transmit to the EUT a CC message, requesting a change to, e.g. the EIRP, the data rate or the carrier frequency.
 - e3) After the reception by the EUT of the CC message the EUT shall implement the parameters specified in the CC message, within the delay ~~declared by~~ specified for the applicant GSO Satellite Network for compliance with the present document.

The events from e1) to e3) shall be displayed and verified with the oscilloscope or recorded command time and by measurement of the transmitted signal.

6.5.6 Network control commands

6.5.6.1 Test method

The following tests shall be performed in sequence:

- Transmission enable command.
- Transmission disable command.
- Identification request.
- a) Transmission enable command:
 - a1) The EUT shall be switched-on and the STE shall transmit the CC.
 - a2) The EUT shall enter the initial phase state.
 - a3) A call (or data transmission) shall be initiated from the EUT, the EUT shall remain in the Transmission disabled state.
 - a4) The STE shall transmit an enable command addressed to the EUT.

- a5) A call shall be initiated from the EUT.
- a6) The EUT shall enter the carrier-on state and shall transmit at the transmission parameters specified in the CC received from the STE.

The events from a2) to a6) shall be displayed and verified with the oscilloscope or recorded command time and by measurement of the transmitted signal.

- b) Transmission disable command:
 - b1) Continue from a6).
 - b2) The STE shall transmit a disable command to the EUT.
 - b3) The EUT shall enter the Transmission disabled state within 1 s.
 - b4) A call (or data transmission) shall be initiated from the EUT.
 - b5) The EUT shall remain in the Transmission disabled state.
 - b6) The STE shall transmit an enable command.
 - b7) A call (or data transmission) shall be initiated from the EUT.
 - b8) The EUT shall enter the carrier-on state and shall transmit.

The events from b2) to b8) shall be displayed and verified with the oscilloscope or recorded command time and by measurement of the transmitted signal.

- c) Identification request:
 - c1) Continue from b8).
 - c2) The STE shall transmit an identification request.
 - c3) The EUT shall transmit its identification code.

The STE shall display the identification code sent by the EUT.

6.5.7 Initial burst transmission

6.5.7.1 Test method

This test procedure applies only to AESs which are designed to transmit initial bursts.

- a) The EUT is switched-off and the STE shall be transmitting the CC.
- b) The EUT shall be switched-on and shall enter the initial state.
- c) The EUT shall not transmit, except the initial bursts, if any.
- d) Each initial burst shall not last more than 1 s, and the transmission of the initial bursts shall not exceed 1 % of the time.

The events from b) to d) shall be displayed and verified with the oscilloscope or recorded command time and by measurement of the transmitted signal.

6.6 Receive antenna off-axis gain pattern

6.6.1 Test method

6.6.1.1 Test site

This test shall be performed on either an outdoor far field test site or compact test range. However if the near field scanner technology to convert near field measurements to far field results is proven ~~and sufficiently accurate to be within measurement uncertainty given in annex C~~ by reference to tests taken in ~~both regions~~ far field region then antenna measurements may be taken in the near field. Fully automated systems can be used for these tests providing that the results can be proven to be as accurate as if they were done according to the specified method.

6.6.1.2 Method of measurement

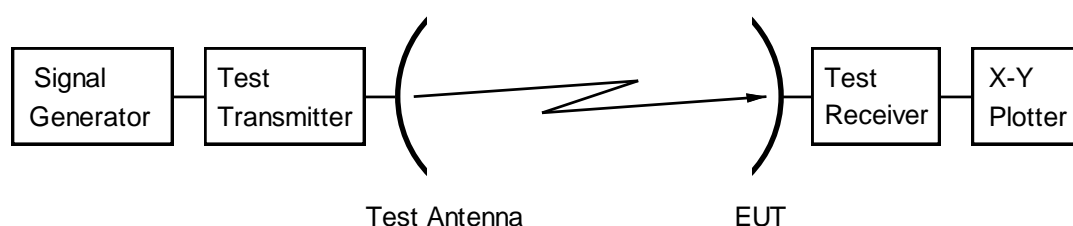

Figure 17: Test arrangement - antenna receive pattern measurement

- a) The test arrangement shall be as shown in figure 17 with the EUT connected to the test receiver.
- b) A signal proportional to the angular position from the servo mechanism shall be applied to the X-axis and the signal level from the test receiver shall be applied to the Y-axis of the plotter.
- c) The test frequencies shall be the centre frequency of each applicable frequency range. The E-plane shall be vertical.
- d) The EUT shall be aligned to maximize the received signal level and the X-Y plotter shall be adjusted to give the maximum reading on the chart.
- e) The EUT shall be driven in azimuth through 180°.
- f) The pattern measurement is then obtained by driving the EUT in azimuth through 360° with the plotter recording the results.
- g) The tests in b) to e) shall be repeated with the frequency changed to the lower limit of the applicable band as ~~declared~~ specified by the manufacturer.
- h) The tests in b) to e) shall be repeated with the frequency changed to the upper limit of the applicable band as ~~declared~~ specified by the manufacturer.
- i) The tests in b) to h) shall be repeated with the frequencies changed to the others specified if the design of the equipment is such that operation is possible, but not necessarily simultaneously, in all bands.
- j) The tests in b) to h) shall be repeated with the test signal being transmitted in the H-plane instead of the E-plane.
- k) The tests in b) to h) shall be repeated with the test signal being transmitted in a plane at 45° to the H-plane.
- l) The tests in b) to h) shall be repeated with the test signal being transmitted in a plane at 90° to that in k).
- m) The tests in b) to l) shall be repeated between the angles of φ_r and 7° with the EUT rotated through 90°, or the test antenna or the polarization subsystem of the EUT rotated by 90°, to give the cross-polar measurement.

6.6.1.3 Computation-

The computation of results shall be carried out by producing a "mask" to the specified limits with the reference level being equal to the gain of the antenna. This reference shall then be placed on the maximum point of the plot obtained from the pattern measurements.

6.7 Blocking performance

6.7.1 General

The test is performed on the LNB of the AES.

For EUTs where the antenna may be removed, the test signal should be introduced into the LNB input. For integrated EUTs where it is not possible to remove the antenna, a radiated method shall be used.

The requirement gives in table 6 the minimum rejection for signals in several frequency ranges.

6.7.2 Test method

- a) The output signals of two signal generators shall be combined with equal weight. The combined signal shall be coupled to the LNB input ~~in a reasonable and appropriate way.~~
- b) A spectrum analyser shall be connected to the LNB output in a way that allows to supply the LNB with power.
- c) f_c is the ~~center~~centre frequency of the receive frequency band.
- d) The first signal generator frequency shall be set to f_c .
- e) The first signal generator level shall be set to ~~a level in the centre of~~ the LNB operational input level range.
- f) The spectrum analyser shall be set for measuring the level of the converted first signal at the LNB output and this LNB output shall be noted.

NOTE: In the following "measured level" refers to this measurement at the output of the LNB.

- g) The second signal generator frequency shall be set to $f_c - 20$ MHz.
- h) The second signal generator level shall be adjusted so that the *measured level* is 1 dB less than ~~in absence of the second signal level~~ noted in step f).
- i) The second signal generator level in step h) shall be noted ~~down as reference level.~~
- j) The second signal generator frequency shall be set to the centre of frequency range 1) of interest table 6.
- k) The second signal generator level shall be adjusted so that the measured level is 1 dB less than the level noted in step f).
- l) The second signal generator frequency shall be swept over the frequency range 1) of table 6 and the *measured level* shall be observed, specifically noting the frequency at which lowest *measured level* is observed.
- ~~a)m)~~ m) The second signal generator shall be set to the frequency where the *measured level* observed in step l) was the lowest.
- ~~b)n)~~ n) The second signal generator level shall be adjusted so that the measured level is 1 dB less than the level noted in absence step f). The level of the second signal generator shall be noted.
- ~~e)o)~~ o) The rejection at the frequency range 1) of interest table 6 is equal to the second signal generator level obtained in step n) minus the reference level determined in step i).
- ~~d)p)~~ p) Steps j) to l) shall be repeated for frequencies in the all frequency ranges of table 56.

NOTE: The worst case rejection in a particular frequency range can be determined after step i) by sweeping the second signal generator frequency over the frequency range and observe the gain compression, then perform steps j) to l) with the frequency where gain compression is highest.

- q) For all frequency ranges of table 6 the rejection obtained in step o) is less or equal the corresponding minimum rejection listed in table 6, then the EUT passes the test.

6.8 Adjacent Signal Selectivity ~~signal selectivity~~

6.8.0 General

The test arrangement is as shown in figure 18.

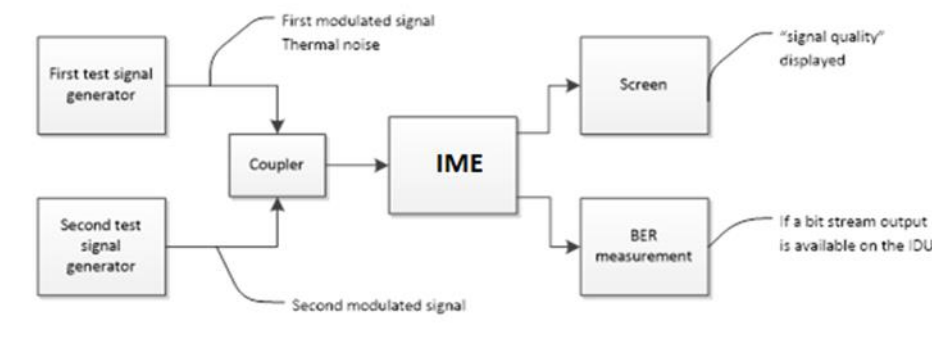

Figure 18: Test set-up for adjacent signal selectivity

6.8.1 Test method

- e)a) Two test signal generators shall be used. Each signal generator shall generate a modulated signal in the IME input frequency range and of the IME. One of the signal generators shall generate in addition thermal noise.
- f)b) The signal generators shall be connected to the IME input through a splitter (combiner).
- c) The test first signal generator signal frequency shall be set to the centre of the IME input frequency range. The signal level shall be set to the centre of the IME input level range.
- g)d) The second signal generator shall be set to the frequencies and levels according to table 6 of the adjacent signal as defined in clause 4.2.9.2.
- h)e) The IME shall be set to receive the signal of the first test signal generator.
- i)f) The second test signal generator shall be set to signal off.
- j)g) The noise level (or signal to noise ratio) of the first test signal generator shall be varied in order to determine the signal to noise ratio threshold reference sensitivity level.
- k)h) The second signal generator shall be set to signal on.
- l)i) The noise level (or signal to noise ratio) of the first test signal generator shall be varied in order to determine the signal to noise ratio threshold reference sensitivity level.
- m)j) The degradation is equal to the noise level (or signal to noise ratio) determined in step h) minus that determined in step f-g).
- n)k) The result is the highest degradation found.

NOTE: Some IMEs display on the connected screen an indication for the estimated bit error rate, for example as "signal quality" between 0 % and 100 %, with 100 % corresponding to quasi error free. This indication may be used for determining the signal to noise ratio thresholds.

Annex A (normative/informative): Relationship between the present document and the essential requirements of Directive 2014/53/EU

The present document has been prepared under the Commission's standardisation request C(2015) 5376 final [i.2i.2] to provide one voluntary means of conforming to the essential requirements of Directive 2014/53/EU on the harmonisation of the laws of the Member States relating to the making available on the market of radio equipment and repealing Directive 1999/5/EC [6i.7].

Once the present document is cited in the Official Journal of the European Union under that Directive, compliance with the normative clauses of the present document given in table A.1 confers, within the limits of the scope of the present document, a presumption of conformity with the corresponding essential requirements of that Directive, and associated EFTA regulations.

~~The present document is therefore intended to cover the provisions of Directive 2014/53/EU [6] (RE Directive) article 3.2 which states that "...radio equipment shall be so constructed that it both effectively uses and supports the efficient use of radio spectrum in order to avoid harmful interference".~~

~~Recital 10 of Directive 2014/53/EU [6] states that "in order to ensure that radio equipment uses the radio spectrum effectively and supports the efficient use of radio spectrum, radio equipment should be constructed so that: in the case of a transmitter, when the transmitter is properly installed, maintained and used for its intended purpose it generates radio waves emissions that do not create harmful interference, while unwanted radio waves emissions generated by the transmitter (e.g. in adjacent channels) with a potential negative impact on the goals of radio spectrum policy should be limited to such a level that, according to the state of the art, harmful interference is avoided; and, in the case of a receiver, it has a level of performance that allows it to operate as intended and protects it against the risk of harmful interference, in particular from shared or adjacent channels, and, in so doing, supports improvements in the efficient use of shared or adjacent channels".~~

~~Recital 11 of Directive 2014/53/EU [6] states that "although receivers do not themselves cause harmful interference, reception capabilities are an increasingly important factor in ensuring the efficient use of radio spectrum by way of an increased resilience of receivers against harmful interference and unwanted signals on the basis of the relevant essential requirements of Union harmonisation legislation".~~

As a consequence, the present document includes both transmitting and receiving parameters to maximize the efficient use of radio spectrum.

Table A.1: Relationship between the present document and the essential requirements of Directive 2014/53/EU

Harmonised Standard ETSI EN 302 186						
The following requirements are relevant to the presumption of conformity under the article 3.2 of Directive 2014/53/EU [6]						
Requirement					Requirement Conditionality	
No	Description	Essential requirements of Directive	Reference: Clause No(s) of the present document	U/C	Condition	
1	SpuriousOff-axis spurious radiation	3.2	4.2.2	U		
2	On-axis spurious radiation	3.2	4.2.3	U		
3	Off-axis EIRP emissions density in the nominated bandwidth	3.2	4.2.4	U		
4	Control and Monitoring Functions (GMFCMFs)	3.2	4.2.5.1	U		
5	Power Flux Density at the surface of the earth	3.2	4.2.5.2	U		
6	Power-on/Reset	4.2.5.3	U			
7	Control Channel (CC) reception	4.2.5.4	U			
8	Network control commands	4.2.5.5	U			
9	Initial burst transmission	4.2.5.6	U			
10	Power flux density limits in the 14,00 GHz to 14,50 GHz frequency band	4.2.6.2	U			
116	Receive Antenna off-axis gain pattern	4.2.7	C	3.2	4.2.7	C
			Satellite communications networks may contain a central control unit that keeps received interference low by taking into account the actual antenna gain pattern of earth stations. The requirement is not relevant for earth stations that are always operated as part of such a network. The requirement is relevant in all other cases. If the receive antenna performance does not meet the requirement in clause 4.2.7, then the earth station shall accept an additional co-frequency interference caused by its off-axis gain which is not compliant to the mask. Receive antenna off-axis gain pattern			
127	Blocking performance	3.2	4.2.8	U		
138	Adjacent Signal Selectivity signal selectivity	3.2	4.2.9	U		

Harmonised Standard ETSI EN 302 186					
The following requirements are relevant to the presumption of conformity under the article 3.2 of Directive 2014/53/EU [6]					
Requirement					Requirement Conditionality
No	Description	Essential requirements of Directive	Reference: Clause No(s) of the present document	U/C	Condition
9	Image frequency rejection	3.2	4.2.10	U	

Key to columns:**Requirement:**

No A unique identifier for one row of the table which may be used to identify a requirement.

Description A textual reference to the requirement.

Essential requirements of Directive

_____ Identification of article(s) defining the requirement in the Directive.

Clause Number(s) of the present document

_____ Identification of clause(s) defining the requirement in the present document unless another document is referenced explicitly.

Requirement Conditionality:

U/C Indicates whether the requirement shall be unconditionally applicable (U) or is conditional upon the manufacturer's claimed functionality of the equipment (C).

Condition Explains the conditions when the requirement shall or shall not be applicable for a requirement which is classified "conditional".

Presumption of conformity stays valid only as long as a reference to the present document is maintained in the list published in the Official Journal of the European Union. Users of the present document should consult frequently the latest list published in the Official Journal of the European Union.

Other Union legislation may be applicable to the product(s) falling within the scope of the present document.

Annex B (normative): Environmental conditions

B.1 General

This annex specifies the environmental conditions under which the relevant requirements of the present document shall be fulfilled.

Testing under other environmental conditions will be undertaken by manufacturers according to the requirements of EUROCAE ED-~~14D-14~~14/RTCA DO-160D [44], and need not be repeated as it is not a requirement of the present document.

NOTE: DO-160D "Environmental Conditions and Test Procedures for Airborne Equipment", Issued 7-29-97, superseded DO-160C, Changes 1, 2 and 3, Prepared by SC-135. Standard procedures and environmental test criteria for testing airborne equipment for the entire spectrum of aircraft from light general aviation aircraft and helicopters through the "Jumbo Jets" and SST categories of aircraft. The document includes 25 sections and three appendices. Examples of tests covered include vibration, power input, radio frequency susceptibility, lightning, and electrostatic discharge.

Coordinated with EUROCAE, RTCA DO-160D and EUROCAE ED-~~14D-14~~14 [44] are identically worded. DO-160C is recognized by the International Organization for Standardization (ISO) as de facto international standard ISO 7137 [i.6].

B.2 Environmental conformance requirements

Aircraft Earth Stations are Installable ~~Equipments~~Equipment (IE) typically consisting of:

- a) an Internally Mounted Equipment (IME) may consist of the following three units:
 - i) a Satellite Terminal Unit (STU);
 - ii) a High Power Amplifier (HPA);
 - iii) a Low Noise Amplifier/Diplexer (LNA/D);
- b) an Externally Mounted Equipment (EME), consisting of an antenna assembly which can be either:
 - i) a single reflector antenna; or
 - ii) two active phased array antennas (one receive and one transmit);
 - iii) a Low Noise Block (LNB) converter.

B.3 Environmental test conditions

The ~~equipments~~equipment comprising the AES may be subject to different environmental hazards and are required to maintain their performance in accordance with the present document under all environmental circumstances for the Equipment Categories applicable to them as defined in EUROCAE ED-~~14D-14~~14 [4]. Whilst the AES being subjected to the EUROCAE ED-~~14D-14~~14 [4] environmental conditions and specifications, tests specified in the present document shall be maintained within the following envelope of environmental conditions (or otherwise as specified by the manufacturer):

- a) for the IME (ambient conditions):
 - temperature: +15 °C to +35 °C;
 - relative humidity: ≤ 85 %;

- pressure: 840 hPa to 1 070 hPa (equivalent to +1 525 m to -460 m altitude).

Tests made at environmental conditions other than ambient as specified above shall be conducted subject to the following ~~tolerances~~limits:

- temperature: ± 3 °C;
- pressure: ± 5 %.

b) for the EME:

- temperature: -55 °C to +35 °C;
- relative humidity: ≤ 85 %;
- pressure: 91 hPa to 1 070 hPa (equivalent to +16 800 m to -460 m altitude).

The power supply shall be in accordance with EUROCAE ED-14D14/RTCA DO-160D [44] Normal Operating Conditions (nominal), for the Equipment Category applicable to the AES.

Annex C (informative): Maximum Measurement Uncertainty

The measurements described in the present document are based on the following assumptions:

- the measured value related to the corresponding limit is used to decide whether an equipment meets the requirements of the present document;
- the value of the measurement uncertainty for the measurement of each parameter is included in the test report.

Tables C.1 and C.2 show the recommended values for the maximum measurement uncertainty figures.

Table C.1: Measurement uncertainty

Measurement parameter	Uncertainty
Radio frequency	± 10 kHz
RF power	$\pm 0,75$ dB
Conducted spurious	± 4 dB
Radiated spurious	± 6 dB
Antenna on-axis gain	± 2 dB

Table C.2: Measurement uncertainties for antenna gain pattern

Gain relative to the antenna on-axis gain	Uncertainty
> -3 dB	$\pm 0,3$ dB
-3 dB to -20 dB	$\pm 1,0$ dB
-20 dB to -30 dB	$\pm 2,0$ dB
-30 dB to -40 dB	$\pm 3,0$ dB

Annex D (informative): Applicability of parameters given in ETSI EG 203 336

ETSI EG 203 336 [i.9] gives guidance on the selection of technical parameters for the production of Harmonised Standards covering articles 3.1(b) and 3.2 of the Radio Equipment Directive [i.7]. Clause 5.3 of ETSI EG 203 336 [i.9] gives receiver parameters under article 3.2 that should be contained in a Harmonised Standard.

Table D.1 explains how these parameters are considered in the present document.

Table D.1: Parameters given in ETSI EG 203 336 [i.9]

ETSI EG 203 336 [i.9]		Present document		Explanation														
Clause	Parameter	Clause	Parameter															
5.3.2	Receiver sensitivity	-	-	There is no causal relationship between receiver sensitivity and interference in the case of satellite communications. Therefore, a quantitative calculation is not possible.														
5.3.3	Receiver co-channel rejection	4.2.7	Receive antenna off-axis gain pattern	Co-channel signals transmitted by other satellite networks are rejected by means of low off-axis antenna gain.														
5.3.4.2.1	Single signal selectivity - receiver adjacent signal selectivity	4.2.9	Adjacent signal selectivity															
5.3.4.2.2	Receiver spurious response rejection	4.2.10	Image frequency rejection	Frequencies other than the image frequency are not relevant because this is covered by receiver blocking and adjacent channel requirements which are already included in the receiver parameters.														
5.3.4.3.1	Receiver blocking	4.2.8	Blocking performance															
5.3.4.3.2	Receiver radio-frequency intermodulation	-	-	<p>In an FSS network, receiver radio-frequency intermodulation is not relevant, because possibly inter-modulating signals originating from other networks are rejected thanks to requirements on receive antenna off-axis gain pattern and adjacent signal selectivity. Interfering signals up to 28 dB above the wanted carrier can be tolerated with minimal impact on performance. See calculation below:</p> <table border="1"> <tbody> <tr> <td>• Co-polar antenna discrimination:</td> <td></td> </tr> <tr> <td>• at 3°</td> <td>-7,5 dB</td> </tr> <tr> <td>• at 5°</td> <td>-21,0 dB</td> </tr> <tr> <td>Adjacent channel selectivity:</td> <td></td> </tr> <tr> <td>• Relative power tolerated in adjacent channel for 0,4 dB degradation in signal to noise ratio threshold</td> <td>+7,0 dB</td> </tr> <tr> <td>• Relative power (arriving at antenna from 3° off-axis)</td> <td>+14,5 dB</td> </tr> <tr> <td>• Relative power (arriving at antenna from 5° off-axis)</td> <td>+28,0 dB</td> </tr> </tbody> </table> <p>Concerning signals originating from the own network, the network operator has control over levels and can prevent intermodulation.</p>	• Co-polar antenna discrimination:		• at 3°	-7,5 dB	• at 5°	-21,0 dB	Adjacent channel selectivity:		• Relative power tolerated in adjacent channel for 0,4 dB degradation in signal to noise ratio threshold	+7,0 dB	• Relative power (arriving at antenna from 3° off-axis)	+14,5 dB	• Relative power (arriving at antenna from 5° off-axis)	+28,0 dB
• Co-polar antenna discrimination:																		
• at 3°	-7,5 dB																	
• at 5°	-21,0 dB																	
Adjacent channel selectivity:																		
• Relative power tolerated in adjacent channel for 0,4 dB degradation in signal to noise ratio threshold	+7,0 dB																	
• Relative power (arriving at antenna from 3° off-axis)	+14,5 dB																	
• Relative power (arriving at antenna from 5° off-axis)	+28,0 dB																	

<u>ETSI EG 203 336 [i.9]</u>		<u>Present document</u>		<u>Explanation</u>
<u>Clause</u>	<u>Parameter</u>	<u>Clause</u>	<u>Parameter</u>	
5.3.4.3.3	Receiver multiple signal selectivity - receiver adjacent signal selectivity	4.2.10	Adjacent signal selectivity	
5.3.4.4.1	Receiver dynamic range	-	-	In an FSS network, receiver dynamic range has no influence on harmful interference. The satellite earth stations are deployed in a manner that results in a situation where it is impossible to receive a wanted signal that is high enough to produce any overloading effect (satellite systems are power limited). So that it is not necessary to specify receiver dynamic range. See clause 5.3.6.1 of ETSI EG 203 336 [i.9].
5.3.4.4.2	Reciprocal mixing	-	-	For FSS equipment, the parameter is excluded for the following reason. It is considered that the reciprocal mixing effects are implicitly covered in HSs where comprehensive interference characteristics are specified in terms of selectivity and/or blocking requirements, thus removing the need for this parameter to be included in HSs as the effects of receiver selectivity and reciprocal mixing cannot be separated. See clause 5.3.6.2 of ETSI EG 203 336 [i.9].
5.3.4.4.3	Desensitization	-	-	As desensitization is a receiver effect addressed by other parameters (including receiver blocking), its inclusion as a separate parameter in an HS is not required. See clause 5.3.2.3 of ETSI EG 203 336 [i.9].
5.3.5	Receiver unwanted emissions in the spurious domain	4.2.2	Off-axis spurious radiation	
		4.2.3	On-axis spurious radiation	

Annex E (informative): Bibliography

- Directive 98/34/EC of the European Parliament and of the Council of 22 June 1998 laying down a procedure for the provision of information in the field of technical standards and regulations.
- ETSI EN 301 489 (all parts): "Electromagnetic compatibility and Radio spectrum Matters (ERM); ElectroMagnetic Compatibility (EMC) standard for radio equipment and services".
- Council Directive 89/336/EEC of 3 May 1989 on the approximation of the laws of the Member States relating to electromagnetic compatibility (EMC Directive).
- Council Directive 73/23/EEC of 19 February 1973 on the harmonization of the laws of Member States relating to electrical equipment designed for use within certain voltage limits (LV Directive).
- ETSI EN 301 427 (V1.2.1): "Satellite Earth Stations and Systems (SES); Harmonized EN for Low data rate Mobile satellite Earth Stations (MESs) except aeronautical mobile satellite earth stations, operating in the 11/12/14 GHz frequency bands covering essential requirements under article 3.2 of the R&TTE directive".
- ETSI EN 301 428 (V1.2.1): "Satellite Earth Stations and Systems (SES); Harmonised EN for Very Small Aperture Terminal (VSAT); Transmit-only, transmit/receive or receive-only satellite earth stations operating in the 11/12/14 GHz frequency bands covering essential requirements under article 3.2 of the R&TTE directive".
- Directive 1999/5/EC of the European Parliament and of the Council of 9 March 1999 on radio equipment and telecommunications terminal equipment and the mutual recognition of their conformity (R&TTE Directive).

History

Document history		
V1.1.1	January 2004	Publication
V2.1.0	February 2016	EN Approval Procedure AP 20160515: 2016-02-15 to 2016-05-16
V2.1.1	May 2016	Publication
<u>V2.2.0</u>	<u>January 2021</u>	<u>EN Approval Procedure AP 20210426: 2021-01-26 to 2021-04-26</u>
<u>V2.2.1</u>	<u>May 2021</u>	<u>Publication</u>