

Across ALL Technology Platforms

Quality for Voice & Video
Communication over IP

Fixed - Mobile
Convergence

Distributed
Speech Recognition

QoS in Digital
Mobile Networks

Quality of
Background Noise
Transmission

E-Model
Transmission
Planning

User related
QoS Parameters

Speech Quality
Test Events



End-to-End Media Quality as Perceived by the User

MOTIVATION

End-to-end communication quality as perceived by the user has always been of major concern to ETSI and its Technical Committee STQ (Speech processing, Transmission and Quality aspects). Recent developments in telecommunications, such as the introduction of VoIP and UMTS increasingly promote the introduction of new services, including wideband speech communication and multimedia. Simultaneously, the global telecommunication landscape is undergoing essential changes, such as the migration from traditional public network operators to NGN service providers.

Liberalization and competition, network interconnection, the impending change to IP technology, real-time multimedia applications and services, have brought major changes over the last few years to the way quality for telecommunications is perceived by the user. The need for a framework to test, measure performance, and achieve Media Quality and Quality of Service (QoS) that takes

into account these changes has become even more necessary.

In a multi-vendor environment standards are the only means to achieve reasonable end-to-end multimedia quality. STQ represents ETSI's commitment to end-to-end multimedia quality for NGN.

End-to-end multimedia quality is **a promotional factor for the market.**

There will be a huge demand for wideband speech communication and multimedia in hands-free, mobile, nomadic and video phone applications in the near future. Devices designed for such applications will have to rely on non-linear and time variant signal processing in terminals and network elements in order to be capable of providing speech quality that satisfies users' demands. Therefore, it is essential to standardize state-of-the-art requirements and test methodologies.

THE CHARTER OF STQ

The objective of TC STQ is to ensure the coordination, production and maintenance of end-to-end quality related standards, for the timely and economic development of equipment for use with existing and future fixed/mobile network telecommunications service offerings. The main working areas of STQ are: Voice and Multimedia over IP (VoIP, MMoIP); excessive acoustic pressure and relevant measurement methods; wideband speech, including terminals, modelling and assessment; and user-oriented QoS.

Within ETSI, **STQ is a center of excellence** for end-to-end single media and multimedia transmission performance, QoS parameters for networks and services and distributed speech recognition, and takes responsibility for related standardization of terminals and networks.

STQ has a charter stretching across ALL technology platforms and thus works in close co-operation

with all ETSI and 3GPP groups involved in communication aspects; this charter also reaches out to other relevant organizations, such as ITU-T, TIA and IEEE. The STQ Aurora working group maintains a set of standards for distributed speech recognition.

STQ Mobile, the working group on mobile services is creating standards on QoS aspects for popular services in GSM™ and Third Generation networks including picture and video quality; new working areas include aspects of Push-to-Talk over Cellular, videotelephony, mobile broadcast, video quality for mobile and picture compression algorithms and the definition of a reference web page in mobile QoS.

The work area of STQ covers dedicated tasks which are of relevance to the European regulatory framework for electronic communications networks and services.

RECENT ACHIEVEMENTS

Among its main accomplishments the Committee sees the six-part standard on QoS aspects for popular services in GSM™ and Third Generation networks, and the complete set of ETSI Guides on user-related QoS parameters, definitions, limits and measurement methods.

Work was completed on an ETSI Guide on excessive acoustic pressure, defining test methodologies for

use under the European Commission (EC) Directive on the health and safety requirements for the exposure of workers to the risks arising from physical agents (noise).

STQ completed its comprehensive report on the quality aspects of IP based communication, covering recent developments designed to handle impairments in IP-based networks.

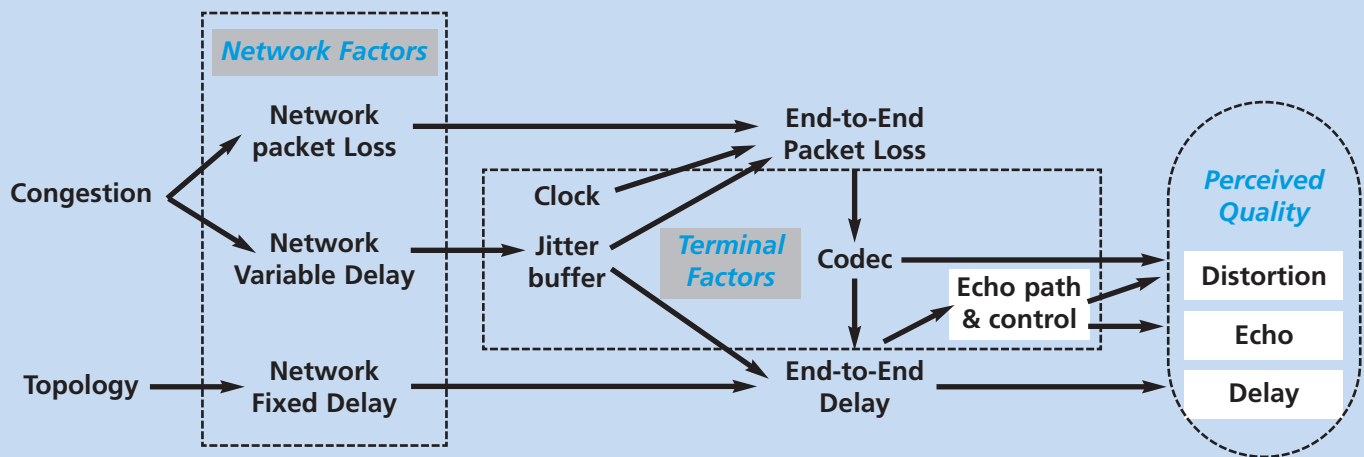

STQ has completed its significant work concerning background noise testing methodologies and measurement. This work is aimed at improving the quality of wideband speech applications by developing a standardized performance testing and **evaluation methodology for the transmission of background noise.**

This work is essential for the high quality wide-band communications needed by many of the applications that the European Commission is promoting such as e-Health and e-Learning.

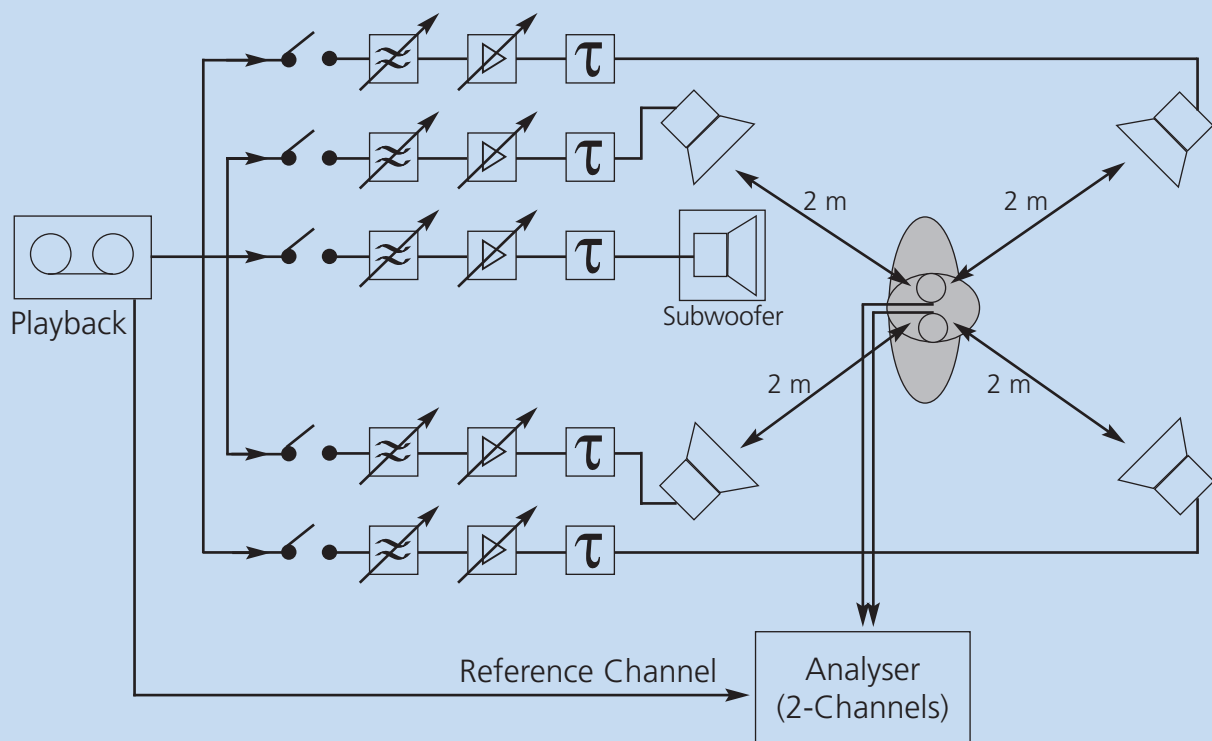

OUTLOOK

The range of work in STQ is expanding. As communications evolve to accommodate other media than simply voice, new work has been initiated to cover the quality of data and video transmission & communication. Upcoming Fixed-Mobile Convergence (FMC) holds for new challenges for end-to-end media quality, as perceived by the user, which are consequently addressed by STQ.

Work on QoS for terminals will encompass DECT™, WiFi, home networks and especially wideband technology.

Average measurements of speech quality over a period of time can disguise poor quality at specific times – often at peak usage times. New interests for the future will include defining speech quality per call, which is expected to lead to the improvement in the quality of individual calls.

3 EXCELLENT REASONS FOR JOINING STQ

- **Participate in the creation & improvement of standards for end-to-end media quality.**
- **Share your own knowledge on media quality and make STQ even better.**
- **Listen to the discussions during regular STQ sessions and special workshops & become part of the excellence.**

For immediate contact: info@etsi-stq.org

ABOUT ETSI

Founded in 1988 to help develop an integrated communications infrastructure in the newly formed European Market, ETSI is one of the three European Standards Organizations and is recognized by the European Union and the European Free Trade Association (EFTA) as the region's competent body for standardization in telecommunications and other electronic communications networks and related services.

The Institute was established as a European body and retains European responsibilities. But ETSI has global membership; many of its Members are global players – over 100 of ETSI's Members (nearly 20% of the total membership) have no established operations in Europe.

ETSI is an independent, non-profit making organization, one of the largest international technical associations in the field of ICT, including telecommunications and broadcasting. Based in Sophia Antipolis in the south of France, ETSI currently numbers over 650 Members from 62 countries around the world – including manufacturers, network operators, administrations, service providers, research bodies and users – an impressive array of international expertise, all working together towards the ultimate goal of a universal information infrastructure.



World Class Standards

www.etsi.org